



# ALLIED MACHINE & ENGINEERING

Holemaking Solutions for Today's Manufacturing



Drilling



Reaming



Burnishing



Threading



Specials

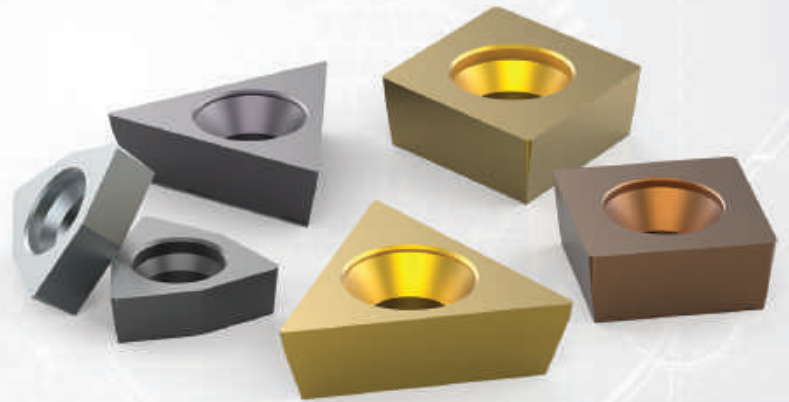

## Wohlhaupter®

► *BORING*

Inserts

**WOHLHAUPTER®**



SECTION

---

# B10-H

---

Inserts

# Wohlhaupter® Inserts

Replaceable Boring Inserts

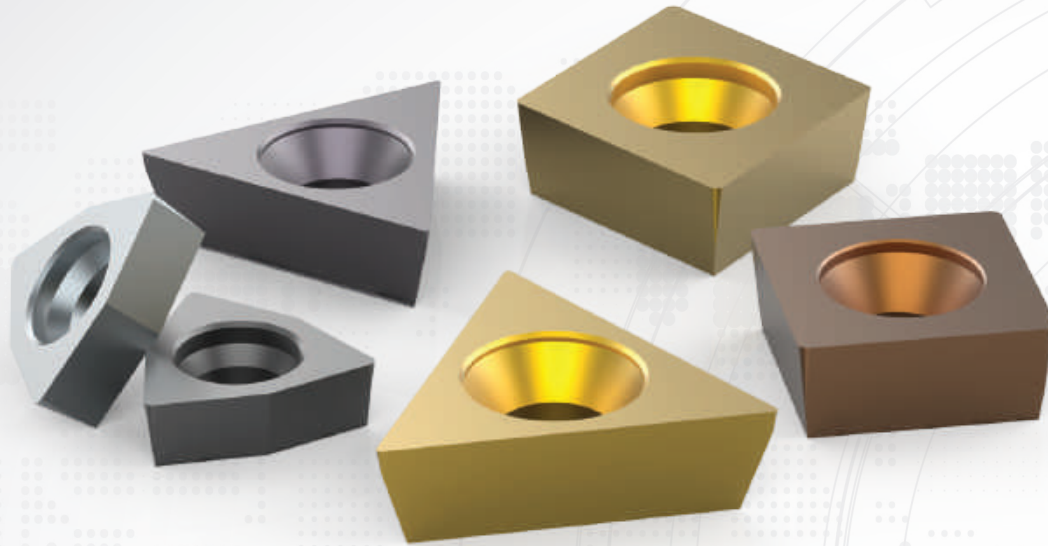

## Cutting-Edge Technology

Wohlhaupter has the cutting-edge technology to achieve all of your boring applications. With precision in mind, our inserts are available in multiple insert geometries, coatings, and nose radii. Wohlhaupter inserts are offered in uncoated and coated carbide, cermet, as well as CBN and PCD materials.

Try our easy-to-use boring insert selector available online or to download from the app store to find the perfect inserts for your boring applications.

[www.alliedmachine.com/bis](http://www.alliedmachine.com/bis)

## Applicable Industries



Aerospace



Agriculture



Automotive



Firearms



General  
Machining



Oil & Gas



Renewable  
Energy

Your safety and the safety of others is very important. This catalog contains important safety messages. Always read and follow all safety precautions.



This triangle is a safety hazard symbol. It alerts you to potential safety hazards that can cause tool failure and serious injury.

When you see this symbol in the catalog, look for a related safety message that may be near this triangle or referred to in the nearby text.

There are safety signal words also used in the catalog. Safety messages follow these words.

### **WARNING**

**WARNING** (shown above) means that failure to follow the precautions in this message could result in tool failure and serious injury.

**NOTICE** means that failure to follow the precautions in this message could result in damage to the tool or machine but not result in personal injury.

**NOTE** and **IMPORTANT** are also used. These are important that you read and follow but are not safety-related.

Visit [www.alliedmachine.com](http://www.alliedmachine.com) for the most up-to-date information and procedures.

### Reference Icons

The following icons will appear throughout the catalog to help you navigate between products.

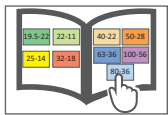

#### MVS Connection Color Guide

Detailed instructions and information regarding the MVS connection(s)

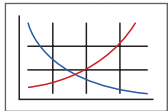

#### Recommended Cutting Data

Speed and feed recommendations for optimum and safe boring

## Wohlhaupter® Inserts Table of Contents

### Product Nomenclature

Wohlhaupter Product Nomenclature . . . . .	2
ISO Insert Nomenclature . . . . .	3

Insert Grades . . . . .	4 - 9
-------------------------	-------

Insert Geometries . . . . .	10 - 13
-----------------------------	---------

### Insert Forms

Form 211 . . . . .	14 - 15
Form 20 . . . . .	16 - 17
Form 161 and 163 . . . . .	18
Form 47 . . . . .	19
Form 101, 103, 104, and 105 . . . . .	20 - 25
Form 123 and 124 . . . . .	26 - 27
Form 39 . . . . .	28 - 29
Form 75 . . . . .	30 - 31
Form 262 and 264 . . . . .	32 - 33
Form 112, 113, and 114 . . . . .	34
Form 04 and 05 . . . . .	35
Grooving Insert Form 89, 90, and 91 . . . . .	36 - 37
Grooving Insert Form 304 . . . . .	38 - 40
Grooving Insert Form 325 . . . . .	41

Insert Accessories . . . . .	42 - 43
------------------------------	---------

### Technical Information

Surface Finish and General Formulas . . . . .	44
Wiper Geometries . . . . .	45

Wear Patterns . . . . .	46
-------------------------	----

## WOHLHAUPTER®

### Boring Insert Selector

Find the best insert for your application.

- Generate the correct boring insert for your job in just six easy steps
- Choose type, shape, substrate, insert form, nose radius, and material
- Order easily by adding the item to your cart

[www.alliedmhcine.com/bis](http://www.alliedmhcine.com/bis)



## Wohlhafter Insert Product Nomenclature

### Reference Key

Symbol	Insert Type
▼	Roughing - Main Application
▽	Roughing - Extended Application
▼▼	Universal - Main Application
▽▽	Universal - Extended Application
▼▼▼	Finishing - Main Application
▽▽▽	Finishing - Extended Application

### Reference Key

Symbol	Machining Conditions
●	Good - Main Application
○	Good - Extended Application
●	Average - Main Application
○	Average - Extended Application
⚙	Difficult - Main Application
⚙	Difficult - Extended Application

### Reference Key

Symbol	Wohlhafter Insert Grades
WHW	Uncoated carbide (HW)
WHC	Coated carbide (HC)
WHT	Uncoated cermet (HT)
WTC	Coated cermet (HC)
WCN	Ceramic cutting material (CN)
WBN	Cubic boron nitride CBN (BN)
WBC	Coated CBN (BC)
PCD	Polycrystalline diamond PCD (DP)

### Wohlhafter Inserts

<b>F101</b>	<b>04</b>	<b>M</b>	<b>N</b>	-	<b>158</b>	<b>W</b>
1	2	3	4		5	6

1. Wohlhafter Insert Form	
211	262
20	264
161	112
163	113
47	114
101	04
103	05
104	89
105	90
123	91
124	304
39	325
75	

2. Corner Radius
<b>Metric (mm)</b>
005 = 0.05 mm
01 = 0.10 mm
02 = 0.20 mm
03 = 0.30 mm
04 = 0.40 mm
06 = 0.60 mm
08 = 0.80 mm
12 = 1.20 mm
16 = 1.60 mm
20 = 2.00 mm
24 = 2.40 mm

3. Tolerance Group		
	<b>Metric (mm)</b>	
	Length of edge	±0.025
<b>G</b>	IC	±0.025
	Thickness	±0.13
	Length of edge	±0.08-0.15*
<b>M</b>	IC	±0.05-0.10*
	Thickness	±0.13
	Length of edge	±0.013
<b>F</b>	IC	±0.005
	Thickness	±0.025
	Length of edge	±0.13
<b>C</b>	IC	±0.025
	Thickness	±0.025
*Varies upon insert size		

4. Machining Direction
N = Neutral
L = Left
R = Right

5. Geometry						
Carbide	Carbide	Tangential	Ceramic	PCD	CBN	
108	155	880	711	530	538	
109	158	811		720	741	
112	161			730	742	
114	161			735	745	
117	174W				747	
121	192				748	
122	199				749	
126	200				768	
127	650					
128	711					
129	840					
145	850					
	860					

6. Optional Information
W = Wiper Geometry

# ISO Insert Nomenclature

## DIN ISO 1832

<b>C</b>	<b>C</b>	<b>M</b>	<b>T</b>	<b>09</b>	<b>T3</b>	<b>02</b>
1	2	3	4	5	6	7

1. Basic Insert Form	2. Clearance Angle	3. Tolerance Group	4. Mounting Style										
<p><b>C</b> = Rhomboid 80°</p> <p><b>D</b> = Rhomboid 55°</p> <p><b>L</b> = Rectangular</p> <p><b>R</b> = Round</p> <p><b>S</b> = Square</p> <p><b>T</b> = Triangular</p> <p><b>V</b> = Rhomboid 35°</p> <p><b>W</b> = Trigon</p>	<p><b>B</b> = 5°</p> <p><b>C</b> = 7°</p> <p><b>N</b> = 0°</p> <p><b>P</b> = 11°</p> <p><b>O</b> = 10°</p>	<p><b>Metric (mm)</b></p> <p>Length of edge ±0.025</p> <p><b>G</b> IC ±0.025</p> <p>Thickness ±0.13</p> <hr/> <p>Length of edge ±0.08-0.15*</p> <p><b>M</b> IC ±0.05-0.10*</p> <p>Thickness ±0.13</p> <hr/> <p>Length of edge ±0.013</p> <p><b>F</b> IC ±0.005</p> <p>Thickness ±0.025</p> <hr/> <p>Length of edge ±0.13</p> <p><b>C</b> IC ±0.025</p> <p>Thickness ±0.025</p> <p>*Varies upon insert size</p>	<table border="1"> <tr> <td><b>T</b> = One-sided countersunk</td> <td>Cylindrical fixing hole Countersunk 40° - 60°</td> </tr> <tr> <td><b>H</b> = One-sided chipbreaker</td> <td>Cylindrical fixing hole Countersunk 70° - 90°</td> </tr> <tr> <td><b>W</b> = Without chipbreaker</td> <td>Cylindrical fixing hole Countersunk 40° - 60°</td> </tr> <tr> <td><b>X</b> = Special design</td> <td>Special insert design</td> </tr> <tr> <td><b>A</b> = Without chipbreaker</td> <td>Cylindrical fixing hole Without countersunk</td> </tr> </table>	<b>T</b> = One-sided countersunk	Cylindrical fixing hole Countersunk 40° - 60°	<b>H</b> = One-sided chipbreaker	Cylindrical fixing hole Countersunk 70° - 90°	<b>W</b> = Without chipbreaker	Cylindrical fixing hole Countersunk 40° - 60°	<b>X</b> = Special design	Special insert design	<b>A</b> = Without chipbreaker	Cylindrical fixing hole Without countersunk
<b>T</b> = One-sided countersunk	Cylindrical fixing hole Countersunk 40° - 60°												
<b>H</b> = One-sided chipbreaker	Cylindrical fixing hole Countersunk 70° - 90°												
<b>W</b> = Without chipbreaker	Cylindrical fixing hole Countersunk 40° - 60°												
<b>X</b> = Special design	Special insert design												
<b>A</b> = Without chipbreaker	Cylindrical fixing hole Without countersunk												

5. Insert Size / Cutting Edge							
Metric (mm)	C	D	R	S	T	V	W
3.97 mm					006		03
5.00 mm					F20		
6.00 mm					F21		
6.35 mm	06				11	11	
7.94 mm				07			
9.52 mm	09	11		09	16	16	
10.00 mm		10					
12.00 mm	12	12					
12.70 mm	16	15		12			
15.87 mm			15	15			
16.00 mm			16				
19.05 mm		19		19			
20.00 mm			20				
25.00 mm			25				
25.40 mm				25			

6. Insert Thickness
<b>Metric (mm)</b>
<b>01</b> = 1.59 mm
<b>02</b> = 2.38 mm
<b>T2</b> = 2.78 mm
<b>03</b> = 3.18 mm
<b>T3</b> = 3.97 mm
<b>04</b> = 4.76 mm
<b>05</b> = 5.56 mm
<b>06</b> = 6.35 mm
<b>07</b> = 7.94 mm

7. Corner Radius
<b>Metric (mm)</b>
<b>005</b> = 0.05 mm
<b>01</b> = 0.10 mm
<b>02</b> = 0.20 mm
<b>03</b> = 0.30 mm
<b>04</b> = 0.40 mm
<b>06</b> = 0.60 mm
<b>08</b> = 0.80 mm
<b>12</b> = 1.20 mm
<b>16</b> = 1.60 mm
<b>20</b> = 2.00 mm
<b>24</b> = 2.40 mm

A  
B  
C  
D  
E  
F  
G  
H  
I  
J  
K  
L  
M  
INDEX

## Wohlhaupter Insert Grades

### Uncoated Carbides

#### Uncoated Carbides

Cutting Material	Description	Material	ISO Application							
			05	10	15	20	25	30	35	40
WHW01 (HW)	<ul style="list-style-type: none"> <li>Fine-grain carbide</li> <li>Finishing &amp; light roughing</li> <li>Non-ferrous metals, cast materials &amp; difficult-to-machine alloys</li> </ul>	P								
		M								
		K								
		N								
		S								
		H								
WHW16 (HW)	<ul style="list-style-type: none"> <li>Fine-grain carbide</li> <li>Finishing &amp; light roughing</li> <li>Non-ferrous metals, cast materials &amp; difficult-to-machine alloys</li> </ul>	P								
		M								
		K								
		N								
		S								
		H								
WHW20 (HW)	<ul style="list-style-type: none"> <li>Tough fine-grain carbide</li> <li>Finishing, roughing &amp; grooving</li> <li>Steel &amp; cast materials, cast steel</li> <li>Non-ferrous materials &amp; difficult-to-machine alloys</li> </ul>	P								
		M								
		K								
		N								
		S								
		H								



## Wohlhaupter Insert Grades

### Coated Carbides

#### Coated Carbides

Cutting Material	Description	Material	ISO Application							
			05	10	15	20	25	30	35	40
WHC05 (HC)	<ul style="list-style-type: none"> <li>PVD coating with nano-composite structure</li> <li>Finishing &amp; roughing</li> <li>Steels, stainless steels, cast materials, &amp; difficult-to-machine alloys</li> </ul>	P								
		M								
		K								
		N								
		S								
		H								
WHC18 (HC)	<ul style="list-style-type: none"> <li>PVD-TiB2 coating</li> <li>Finishing &amp; light roughing</li> <li>Non-ferrous metals</li> </ul>	P								
		M								
		K								
		N								
		S								
		H								
WHC19 (HC)	<ul style="list-style-type: none"> <li>Multilayer PVD coating</li> <li>Finishing &amp; roughing</li> <li>Stainless steels</li> </ul>	P								
		M								
		K								
		N								
		S								
		H								
WHC20 (HC)	<ul style="list-style-type: none"> <li>Multilayer CVD coating</li> <li>Finishing</li> <li>Steels &amp; stainless steels</li> </ul>	P								
		M								
		K								
		N								
		S								
		H								
WHC30 (HC)	<ul style="list-style-type: none"> <li>CVD coating</li> <li>Roughing</li> <li>Steel &amp; cast steel</li> </ul>	P								
		M								
		K								
		N								
		S								
		H								
WHC77 (HC)	<ul style="list-style-type: none"> <li>Fine-grained substrate with modified cobalt to increase strength</li> <li>MT-CVD coating combines advantages of TiCN &amp; Al<sub>2</sub>O<sub>3</sub></li> <li>Versatile material designed for turning gray and ductile iron</li> <li>Rough &amp; finish machining</li> <li>Medium to high cutting speeds</li> <li>Continuous &amp; light to medium interrupted cuts</li> </ul>	P								
		M								
		K								
		N								
		S								
		H								
WHC79 (HC)	<ul style="list-style-type: none"> <li>Multilayer MT CVD coating</li> <li>Roughing &amp; finishing</li> <li>Steels, stainless steels &amp; cast materials</li> </ul>	P								
		M								
		K								
		N								
		S								
		H								
WHC98 (HC)	<ul style="list-style-type: none"> <li>PVD TiAlN coating</li> <li>Roughing &amp; finishing</li> <li>Steels, stainless steels &amp; difficult-to-machine materials</li> </ul>	P								
		M								
		K								
		N								
		S								
		H								

## Wohlhaupter Insert Grades

### Coated Carbides

#### Coated Carbides

Cutting Material	Description	Material	ISO Application							
			05	10	15	20	25	30	35	40
WHC111 (HC)	<ul style="list-style-type: none"> <li>PVD TiAlN coating</li> <li>Finishing</li> <li>Machining of steels after heat treating with high Cr content up to 60 HRC</li> <li>Hard - soft transitions, difficult-to-machine alloys &amp; stainless steels</li> </ul>	P								
		M								
		K								
		N								
		S								
		H								
WHC114 (HC)	<ul style="list-style-type: none"> <li>Multilayer PVD coating</li> <li>Finishing &amp; roughing</li> <li>Steels, stainless steels, &amp; difficult-to-machine materials</li> </ul>	P								
		M								
		K								
		N								
		S								
		H								
WHC136 (HC)	<ul style="list-style-type: none"> <li>Stronger PVD coating with improved coating adhesion</li> <li>High oxidation resistance allows a wide range of applications</li> </ul>	P								
		M								
		K								
		N								
		S								
		H								
WHC164 (HC)	<ul style="list-style-type: none"> <li>Thick MT-CVD coating with a dominant AC<sub>2</sub>O<sub>3</sub></li> <li>Primarily developed for the material groups P-K &amp; alternatively H</li> <li>Full &amp; discontinuous cut</li> <li>High cutting speeds possible</li> </ul>	P								
		M								
		K								
		N								
		S								
		H								
WHC168 (HC)	<ul style="list-style-type: none"> <li>Multilayer MT CVD coating</li> <li>Excellent combination of toughness &amp; reliability</li> <li>Steels, cast materials &amp; alternatively for stainless steel</li> </ul>	P								
		M								
		K								
		N								
		S								
		H								
WHC198 (HC)	<ul style="list-style-type: none"> <li>Upgraded PVD grade with hard AlTiN coating</li> <li>Optimized cutting edge stability</li> <li>General machining of steel, stainless steel, high-temperature resistant alloys, titanium, iron, cast iron, &amp; non-ferrous materials</li> </ul>	P								
		M								
		K								
		N								
		S								
		H								
WHC190 (HC)	<ul style="list-style-type: none"> <li>Newest generation multilayer PVD coating</li> <li>Finishing &amp; roughing</li> <li>Extremely universal &amp; the first choice for poor machining conditions</li> <li>Excellent in cast steels, stainless steels, &amp; super alloys</li> </ul>	P								
		M								
		K								
		N								
		S								
		H								

## Wohlhaupter Insert Grades

Uncoated Cermet | Coated Cermet

### Uncoated Cermet

Cutting Material	Description	Material	ISO Application							
			05	10	15	20	25	30	35	40
WHT10 (HT)	<ul style="list-style-type: none"> <li>Uncoated cermet</li> <li>Finishing</li> <li>Steels, stainless steels &amp; cast materials</li> </ul>	P								
		M								
		K								
		N								
		S								
		H								
WHT12 (HC)	<ul style="list-style-type: none"> <li>Uncoated cermet</li> <li>Finishing</li> <li>Steels, cast materials, sintered metals, &amp; non-ferrous metals</li> </ul>	P								
		M								
		K								
		N								
		S								
		H								
WHT32 (HC)	<ul style="list-style-type: none"> <li>Uncoated cermet</li> <li>Finishing</li> <li>Steels &amp; cast materials</li> </ul>	P								
		M								
		K								
		N								
		S								
		H								

### Coated Cermet

Cutting Material	Description	Material	ISO Application							
			05	10	15	20	25	30	35	40
WTC15 (TC)	<ul style="list-style-type: none"> <li>New PVD brilliant coating</li> <li>Reduce friction coefficient in turning applications</li> <li>Coated cermet general purpose grade for material group</li> <li>Achieves excellent surface finish with excellent wear resistance</li> <li>Usable in stainless steels</li> </ul>	P								
		M								
		K								
		N								
		S								
		H								
WTC121 (TC)	<ul style="list-style-type: none"> <li>PVD coated cermet</li> <li>Finishing of steels &amp; stainless steels</li> </ul>	P								
		M								
		K								
		N								
		S								
		H								

## Wohlhaupter Insert Grades

Uncoated Cubic Boron Nitride | Coated Cubic Boron Nitride

### Uncoated Cubic Boron Nitride

Cutting Material	Description	Material	ISO Application							
			05	10	15	20	25	30	35	40
WBN150 (BN)	<ul style="list-style-type: none"> <li>Uncoated CBN grade</li> <li>Roughing &amp; finishing smooth &amp; slightly discontinuous cuts</li> <li>Hardened steels 58 - 64 HRC</li> <li>Grain size 2 µm</li> <li>CBN content: 50%</li> </ul>	P								
		M								
		K								
		N								
		S								
		H								
WBN200 (BN)	<ul style="list-style-type: none"> <li>Uncoated CBN grade</li> <li>Roughing &amp; finishing highly discontinuous cuts</li> <li>Hardened steels 58 - 64 HRC</li> <li>Grain size 3 µm</li> <li>CBN content: 65%</li> </ul>	P								
		M								
		K								
		N								
		S								
		H								
WBN300 (BN)	<ul style="list-style-type: none"> <li>Uncoated CBN grade</li> <li>Roughing &amp; finishing smooth cuts</li> <li>Hardened steels 58 - 64 HRC</li> <li>Grain size 0.5 - 1.0 µm</li> <li>CBN content: approximately 50%</li> </ul>	P								
		M								
		K								
		N								
		S								
		H								
WBN450 (BN)	<ul style="list-style-type: none"> <li>Uncoated CBN grade</li> <li>Roughing &amp; finishing smooth &amp; discontinuous cuts</li> <li>Pearlite grey cast iron &amp; sintered metals</li> <li>Grain size 2 µm</li> <li>CBN content: 90%</li> </ul>	P								
		M								
		K								
		N								
		S								
		H								

### Coated Cubic Boron Nitride

Cutting Material	Description	Material	ISO Application							
			05	10	15	20	25	30	35	40
WBC... (BC)	<ul style="list-style-type: none"> <li>Single and multiple assembled</li> <li>Different sizes &amp; designs available upon request. Please contact our Application Engineering Department</li> <li><i>email: <a href="mailto:appeng@alliedmachine.com">appeng@alliedmachine.com</a></i></li> <li><i>ext: 7611</i></li> </ul>	P								
		M								
		K								
		N								
		S								
		H								

## Wohlhaupter Insert Grades

Polycrystalline Diamond | Ceramic Cutting Material

### Polycrystalline Diamond

Cutting Material	Description	Material	ISO Application							
			05	10	15	20	25	30	35	40
PCD D30 (DP)	<ul style="list-style-type: none"> <li>PCD medium grain grade</li> <li>Finishing</li> <li>Al alloys &amp; Mg alloys up to 12% Si</li> <li>Grain size 10 µm</li> </ul>	P								
		M								
		K								
		N								
		S								
		H								
PCD D50 (DP)	<ul style="list-style-type: none"> <li>PCD mixed-grain grade</li> <li>Finishing</li> <li>CFRP, GRP, MMC, Al alloys over 12% Si</li> <li>Grain size 2 - 30 µm</li> </ul>	P								
		M								
		K								
		N								
		S								
		H								

### Ceramic Cutting Material











Cutting Material	Description	Material	ISO Application							
			05	10	15	20	25	30	35	40
WCN06 (CN)	<ul style="list-style-type: none"> <li>Uncoated silicon-nitride ceramic</li> <li>Roughing</li> <li>Pearlite grey cast iron</li> </ul>	P								
		M								
		K								
		N								
		S								
		H								

A  
B  
C  
D  
E  
F  
G  
H  
I  
J  
K  
L  
M  
INDEX

## Wohlhaupter Insert Geometries

Cermet | Carbide



























Cermet | Carbide

Geometry	Description	Application	Available Form
108 	<ul style="list-style-type: none"> <li>Sintered chip breaker for higher feeds</li> <li>Suitable for highly discontinuous cuts</li> </ul>	▼▼▼ ▼	F101, F103, F104, F112, F113
109 	<ul style="list-style-type: none"> <li>Sintered geometry with V-shaped chip breaker for roughing &amp; finishing</li> <li>Good chip control even for shallow depth of cut</li> </ul>	▼▼▼ ▼	F101, F103, F104
112 	<ul style="list-style-type: none"> <li>Sintered chip breaker</li> <li>Finishing &amp; light roughing</li> </ul>	▼▼▼ ▼	F101, F03
117 	<ul style="list-style-type: none"> <li>Sintered geometry for medium machining &amp; roughing</li> <li>Main application in material groups P, M, &amp; K</li> </ul>	▼▼▼ ▼	F75, F123, F124
121 	<ul style="list-style-type: none"> <li>Positive geometry with stable cutting edge</li> <li>Finishing in different material groups</li> <li>Good chip control</li> </ul>	▼▼▼	F20, F211
122 	<ul style="list-style-type: none"> <li>Sintered chip breaker</li> <li>Good chip control - even with long-chipping materials</li> </ul>	▼▼▼	F101, F103, F161
126 	<ul style="list-style-type: none"> <li>Sintered version with a wide range of applications</li> </ul>	▼	F105
127 	<ul style="list-style-type: none"> <li>Highly positive sintered geometry</li> <li>For non-ferrous metals &amp; cast iron</li> </ul>	▼▼▼ ▼	F39, F101, F103, F104, F112, F113, F262, F264
128 	<ul style="list-style-type: none"> <li>Highly positive sintered geometry</li> <li>Polished for finishing non-ferrous metals, cast iron, &amp; steel</li> </ul>	▼▼▼	F20
129 	<ul style="list-style-type: none"> <li>Highly positive chip breaking geometry</li> <li>Polished for non-ferrous metals, cast iron, &amp; steel</li> <li>Ideal for structural steel applications</li> </ul>	▼▼▼ ▼	F39, F101, F103, F262, F264
145 	<ul style="list-style-type: none"> <li>Geometry for finishing in smooth &amp; discontinuous cut</li> <li>Good chip control - even with long-chipping materials</li> </ul>	▼▼▼ ▼	F101, F103, F112, F113, F161

## Wohlhaupter Insert Geometries

Cermet | Carbide

Cermet | Carbide



Geometry	Description	Application	Available Form
155 	<ul style="list-style-type: none"> <li>Positive sintered geometry</li> <li>Special cutting edge design in combination with the chip breaker design enables exceptional chip control even at shallow cutting depths &amp; light feeds</li> </ul>		F20, F101, F103, F39, F264
158 	<ul style="list-style-type: none"> <li>Stable sintered geometry for roughing &amp; finishing with &amp; without discontinuous cuts</li> </ul>		F75, F101, F103, F104, F105, F113, F114, F123, F124, F163
161 	<ul style="list-style-type: none"> <li>Slightly positive &amp; stable geometry</li> <li>Main application material groups S &amp; M. Alternatively suitable for P &amp; K</li> <li>Roughing &amp; finishing in full &amp; interrupted cuts</li> </ul>		F75, F123
167 	<ul style="list-style-type: none"> <li>Positive sintered geometry with sharp cutting edges</li> <li>Finishing up to medium machining</li> <li>Excellent for M &amp; S materials</li> </ul>		F75, F123
174W 	<ul style="list-style-type: none"> <li>Wiper geometry for highly productive turning &amp; boring</li> <li>Can be used with pitch angle 92° - 95°</li> <li>Good chip breaking properties even at lower feed rates</li> </ul>		F101, F103
192 	<ul style="list-style-type: none"> <li>Sintered version for a variety of applications</li> <li>Low cutting pressure because of sharp cutting edge prep</li> </ul>		F39, F101, F103, F104, F112, F113, F163, F161, F262, F264
199 	<ul style="list-style-type: none"> <li>Positive sintered geometry for wide variety of applications</li> <li>Special chip breaker allows chip control with different radial depth of cut</li> </ul>		F101, F103, F104, F112, F113
200 	<ul style="list-style-type: none"> <li>Highly positive sintered geometry</li> <li>Applicable for various material groups for low cutting pressure</li> </ul>		F39, F101, F103, F104, F264
650 	<ul style="list-style-type: none"> <li>Obliquely ground chip breaker reduces cutting forces</li> <li>Finishing &amp; smooth interrupted cuts</li> </ul>		F20, F211
711 	<ul style="list-style-type: none"> <li>Negative geometry with 0 rake suitable for fine finishing and semi roughing</li> <li>Machined materials in groups K &amp; H</li> <li>Continuous and moderately interrupted cut</li> </ul>		F101, F103, F104, F113, F163
840 	<ul style="list-style-type: none"> <li>Parallel ground chip breaker</li> <li>For finish operations with stable cutting edge</li> </ul>		F20
850 	<ul style="list-style-type: none"> <li>Parallel ground chip breaker</li> <li>Good chip control with short to medium feeds</li> </ul>		F161
860 	<ul style="list-style-type: none"> <li>Parallel ground chip breaker reduces cutting forces</li> <li>Stable for a wide range of applications</li> </ul>		F101, F103, F104, F105, F325

A  
B  
C  
D  
E  
F  
G  
H  
I  
J  
K  
L  
M  
INDEX

## Wohlhaupter Insert Geometries

Tangential | Ceramic

### Tangential

Geometry	Description	Application	Available Form
880 	<ul style="list-style-type: none"> <li>Large parallel ground chip breaker with 10° rake angle for reduced cutting force</li> </ul>	▼	F04, F05
811 	<ul style="list-style-type: none"> <li>Smooth geometry without additional ground chip breaker</li> <li>Reinforced cutting edges provide stability</li> <li>Excellent for cast materials</li> </ul>	▼	F05

### Ceramic









Geometry	Description	Application	Available Form
711 	<ul style="list-style-type: none"> <li>Smooth geometry with 0° rake angle</li> <li>High cutting edge stability particularly in discontinuous cuts</li> </ul>	▼	F75, F103, F104, F123













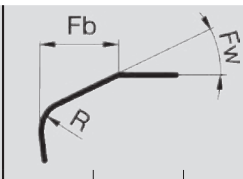





## Wohlhaupter Insert Geometries

PCD | CBN

### PCD

Geometry	Description	Application	Available Form
530 	<ul style="list-style-type: none"> <li>PCD-tipped cutting edge</li> </ul>		F101, F103
720 	<ul style="list-style-type: none"> <li>Smooth geometry in positive version with 7° rake angle for PCD</li> <li>Sharp cutting edge</li> </ul>		F20, F101, F103
730 	<ul style="list-style-type: none"> <li>Smooth geometry with 0° rake angle for PCD</li> <li>Sharp cutting edge</li> </ul>		F20, F39, F75, F101, F103, F123, F211, F262, F264
735 	<ul style="list-style-type: none"> <li>Smooth geometry</li> <li>Laser-cut chip breaker for PCD</li> <li>Suitable for long-chipping aluminum wrought alloys</li> </ul>		F20, F39, F101, F103, F211, F262, F264

### CBN

Geometry	Description				Application	Available Form
		R	Fb	Fw		
548 	<ul style="list-style-type: none"> <li>Smooth geometry with 0° rake angle for afforded CBN</li> <li>Rounded cutting edge - not for chamfering</li> <li>For cast materials</li> </ul>	0.015				F101, F103
741 	<ul style="list-style-type: none"> <li>Smooth geometry with 0° rake angle for CBN</li> <li>Rounded cutting edge with 30° chamfer</li> </ul>	0.015	0.15	30°		F20, F101, F103
742 	<ul style="list-style-type: none"> <li>Smooth geometry with 0° rake angle for CBN</li> <li>Rounded cutting edge with 15° chamfer</li> </ul>	0.015	0.1	15°		F20, F101, F103
745 	<ul style="list-style-type: none"> <li>Smooth geometry with 0° rake angle for CBN</li> <li>Rounded cutting edge with 30° chamfer</li> </ul>	0.015	0.05	30°		F20, F211
747 	<ul style="list-style-type: none"> <li>Smooth geometry with 0° rake angle for CBN</li> <li>Rounded cutting edge with a small 20° chamfer</li> </ul>	0.015	0.1	20°		F39, F104, F262, F264
748 	<ul style="list-style-type: none"> <li>Smooth geometry with 0° rake angle for CBN</li> <li>Rounded cutting edge</li> <li>No chamfer</li> </ul>	0.015	0.2	20°		F20, F101, F103, F211
749 	<ul style="list-style-type: none"> <li>Smooth geometry with 0° rake angle for CBN</li> <li>Rounded cutting edge with a large 20° chamfer</li> </ul>	0.015				F75, F123, F264
768 	<ul style="list-style-type: none"> <li>Smooth geometry with 7° rake angle for CBN</li> <li>Rounded cutting edge</li> </ul>	0.015				F20, F101, F103

A  
B  
C  
D  
E  
F  
G  
H  
I  
J  
K  
L  
M  
INDEX

# Insert Form 211

Cermet | Carbide

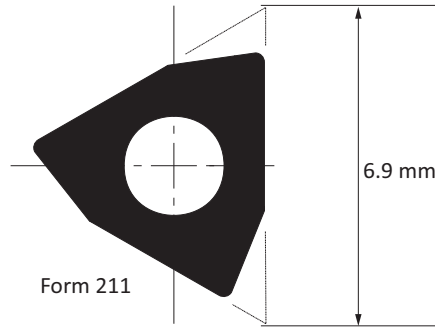

						Cermet						Carbide															
						Uncoated			Coated			Uncoated			Coated												
Material	Grade					WHT10	WHT12	WHT16	WHT32	WTC15	WTC121	WHW01	WHW16	WHC05	WHC18	WHC19	WHC79	WHC98	WHC111	WHC114	WHC136	WHC164					
Steel	P					▼▼▼							▼▼▼	▼▼▼	▼▼▼			▼▼▼	▼▼▼	▼▼▼	▼▼▼						
Stainless Steel	M												▼▼▼	▼▼▼	▼▼▼			▼▼▼	▼▼▼	▼▼▼	▼▼▼						
Cast Iron	K					▼▼▼					▼▼▼		▼▼▼	▼▼▼	▼▼▼			▼▼▼	▼▼▼	▼▼▼	▼▼▼						
Non-Ferrous Materials	N					▼▼▼					▼▼▼		▼▼▼	▼▼▼	▼▼▼			▼▼▼	▼▼▼	▼▼▼	▼▼▼						
Titanium	S										▼▼▼		▼▼▼	▼▼▼	▼▼▼			▼▼▼	▼▼▼	▼▼▼	▼▼▼						
Hard Materials	H																	▼▼▼	▼▼▼	▼▼▼	▼▼▼						
Geometry	Radius		ISO Code	Description	Part No.																						
	in	mm				WHT10	WHT12	WHT16	WHT32	WTC15	WTC121	WHW01	WHW16	WHC05	WHC18	WHC19	WHC79	WHC98	WHC111	WHC114	WHC136	WHC164					
121	0.004	0.10	WBGX030101	F21101GN121	397675										⚙			⚙									
121	0.008	0.20	WBGX030102	F21102GN121	397676										⚙			⚙									
650	0.004	0.10	WBGX030101	F21101GL650	097755		●				●		●	●							●						
650	0.008	0.20	WBGX030102	F21102GL650	097454		●				●		●								●						

### Reference Key

Symbol	Machining Conditions
●	Good - Main Application
◐	Average - Main Application
⚙	Difficult - Main Application

### Reference Key

Symbol	Insert Type
▼▼▼	Finishing - Main Application
▽▽▽	Finishing - Extended Application

Insert Form	Countersunk Screw		Torque Driver	Service Key	Technical Data	
	Part No.	Size	Part No.	Part No.	Torque	Key Size
211	215377	M2 x 0.4 x 4	415507	115537	0.6 Nm	T6

# Insert Form 211

CBN | PCD

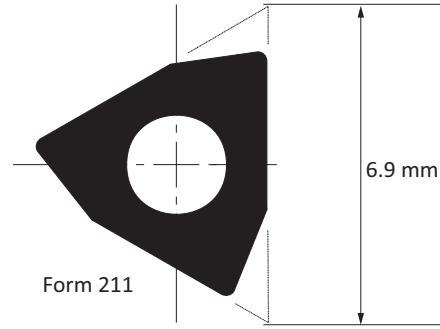

						Ceramic		CBN				PCD		
						Uncoated	Coated	Uncoated		Coated				
Steel						P								
Stainless Steel						M								
Cast Iron						K				▼▼▼				
Non-Ferrous Materials						N						▼▼▼▼▼		
Titanium						S								
Hard Materials						H			▼▼▼					
Geometry	Radius		ISO Code	Description	Part No.									
	in	mm				WBN150	WBN200	WBN300	WBN450	PKDD30	PKDD50			
730	0.004	0.10	WBGX030101	F21101GN730	397763								●	
730	0.008	0.20	WBGX030102	F21102GN730	097557								●	●
735	0.008	0.20	WBGX030102	F21102GN735	397237								●	
748	0.004	0.10	WBGX030101	F21101GN748	097486				●					●
748	0.008	0.20	WBGX030102	F21102GN748	097552				●		●			

Insert Form	Countersunk Screw		Torque Driver	Service Key	Technical Data	
					Torque	Key Size
211	215377	M2 x 0.4 x 4	415507	115537	0.6 Nm	T6

Reference Key

Symbol	Machining Conditions
●	Average - Main Application

Reference Key

Symbol	Insert Type
▼▼▼	Finishing - Main Application

A  
B  
C  
D  
E  
F  
G  
H  
I  
J  
K  
L  
M  
INDEX

### Insert Form 20

Cermet | Carbide

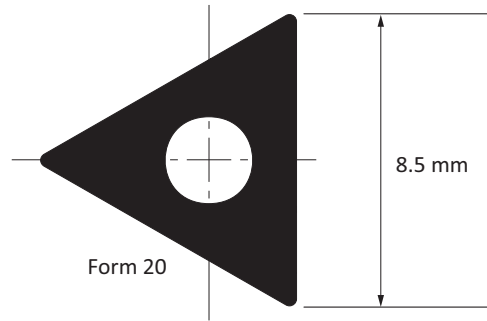

						Cermet						Carbide									
						Uncoated			Coated			Uncoated			Coated						
Material	Grade					WHT10	WHT12	WHT16	WHT32	WTC15	WTC121	WHW01	WHW16	WHC05	WHC18	WHC19	WHC79	WHC98	WHC111	WHC114	WHC136
Steel	P					▼▼				▼▼	▼▼			▼▼		▼▼			▼▼		▼▼
Stainless Steel	M									▼▼	▼▼			▼▼		▼▼			▼▼		▼▼
Cast Iron	K					▼▼				▼▼			▼▼	▼▼		▼▼			▼▼		▼▼
Non-Ferrous Materials	N					▼▼							▼▼	▼▼		▼▼			▼▼		▼▼
Titanium	S										▼▼	▼▼		▼▼		▼▼			▼▼		▼▼
Hard Materials	H																		▼▼		▼▼
Geometry	Radius		ISO Code	Description	Part No.	WHT10	WHT12	WHT16	WHT32	WTC15	WTC121	WHW01	WHW16	WHC05	WHC18	WHC19	WHC79	WHC98	WHC111	WHC114	WHC136
121	0.004	0.10	TOGX080201	F02001GN121	397672											●			●		
121	0.008	0.20	TOGX080202	F02002GN121	397673											●			●		
121	0.016	0.40	TOGX080204	F02004GN121	397674											●			●		
128	0.008	0.20	TOGX080202	F02002GN128	297541							●	●	●							
128	0.016	0.40	TOGX080204	F02004GN128	297542							●	●	●							
155	0.008	0.20	TOMX080202	F02002MN155	397688					●											
155	0.016	0.40	TOMX080204	F02004MN155	397689					●											
650	0.004	0.10	TOGX080201	F02001GL650	097153		●				●	●		●							●
650	0.008	0.20	TOGX080202	F02002GL650	097546		●				●	●		●							●
650	0.012	0.30	TOGX080203	F02003GL650	097154						●	●		●							●
650	0.016	0.40	TOGX080204	F02004GL650	097599		●				●	●		●							●
650	0.031	0.80	TOGX080208	F02008GL650	397764							●									●
840	0.008	0.20	TOGX080202	F02002GR840	097701		●							●							

Reference Key

Symbol	Machining Conditions
●	Good - Main Application
●	Average - Main Application
⚙	Difficult - Main Application

Reference Key

Symbol	Insert Type
▼▼	Finishing - Main Application
▽▽	Finishing - Extended Application

Insert Form	Countersunk Screw		Torque Driver	Service Key	Technical Data	
	Part No.	Size	Part No.	Part No.	Torque	Key Size
20	115535	M2 x 0.4 x 5	415508	115591	0.9 Nm	T7

## Insert Form 20

CBN | PCD

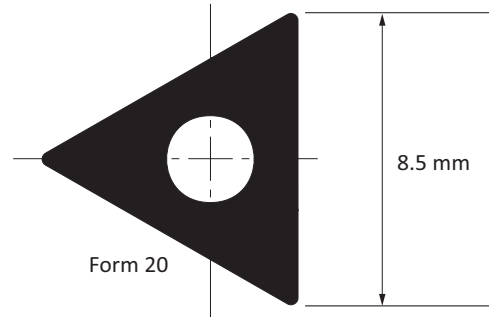

						CBN				PCD	
						Uncoated		Coated			
						WBK150	WBK200	WBK300	WBK450	PKDD30	PKDD50
Geometry	Radius		ISO Code	Description	Part No.						
	in	mm									
<b>Steel</b>											
<b>Stainless Steel</b>											
<b>Cast Iron</b>						▼▼	▼▼				
<b>Non-Ferrous Materials</b>										▼▼	▼▼
<b>Titanium</b>											
<b>Hard Materials</b>							▼▼	▼▼			
<b>720</b>	0.008	0.20	TOGX080202	F02002GN720	297692					●	
<b>720</b>	0.016	0.40	TOGX080204	F02004GN720	297845					●	
<b>730</b>	0.008	0.20	TOGX080202	F02002GN730	097487					●	●
<b>730</b>	0.016	0.40	TOGX080204	F02004GN730	097686					●	●
<b>730</b>	0.031	0.80	TOGX080208	F02008GN730	097877					●	
<b>735</b>	0.008	0.20	TOGX080202	F02002GN735	397133					●	
<b>735</b>	0.016	0.40	TOGX080204	F02004GN735	397301					●	
<b>741</b>	0.008	0.20	TOGX080202	F02002GN741	297260		●				
<b>741</b>	0.016	0.40	TOGX080204	F02004GN741	297262		●				
<b>742</b>	0.008	0.20	TOGX080202	F02002GN742	297264			●			
<b>742</b>	0.016	0.40	TOGX080204	F02004GN742	397610			●			
<b>745</b>	0.004	0.10	TOGX080201	F02001GN745	297259		●				
<b>748</b>	0.008	0.20	TOGX080202	F02002GN748	297780				●		
<b>748</b>	0.016	0.40	TOGX080204	F02004GN748	297782				●		
<b>768</b>	0.008	0.20	TOGX080202	F02002GN768	397146				●		
<b>768</b>	0.016	0.40	TOGX080204	F02004GN768	397192				●		

Insert Form	Countersunk Screw		Torque Driver	Service Key	Technical Data	
					Torque	Key Size
20	115535	M2 x 0.4 x 5	415508	115591	0.9 Nm	T7

### Reference Key

Symbol	Machining Conditions
●	Good - Main Application
●	Average - Main Application

### Reference Key

Symbol	Insert Type
▼▼	Finishing - Main Application

A  
B  
C  
D  
E  
F  
G  
H  
I  
J  
K  
L  
M  
INDEX

## Insert Forms 161, 163

Cermet | Carbide

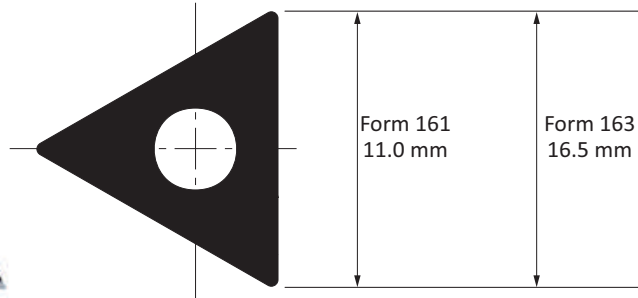

						Cermet						Carbide													
						Uncoated			Coated			Uncoated			Coated										
						WHT10	WHT12	WHT16	WHT32	WTC15	WTC121	WHW01	WHW16	WHC05	WHC18	WHC19	WHC77	WHC79	WHC111	WHC114	WHC136	WHC164			
Geometry	Radius		ISO Code	Description	Part No.																				
	in	mm																							
Steel	P																								
Stainless Steel	M																								
Cast Iron	K																								
Non-Ferrous Materials	N																								
Titanium	S																								
Hard Materials	H																								
122	0.016	0.40	TCMT110204	F16104MN122	097953	●																			
129	0.008	0.20	TCGT110202	F16102GN129	397769							●	●												
129	0.016	0.40	TCGT110204	F16104GN129	397770							●	●												
129	0.016	0.40	TCGT16T304	F16304GN129	397771							●	●												
145	0.016	0.40	TCGT110204	F16104GN145	297993														●						
158	0.016	0.40	TCMT16T304	F16304MN158	297604													●							
192	0.016	0.40	TCMT110204	F16104MN192	397663											⚙									
192	0.016	0.40	TCMT16T304	F16304MN192	397654											⚙							●		
192	0.031	0.80	TCMT16T308	F16308MN192	397772											⚙									
711	0.016	0.40	TCMT16T304	F16304MN711	397898												●								
711	0.031	0.80	TCMT16T308	F16308MN711	397899												●								
850	0.008	0.20	TCGT110202	F16102GL850	097512		●																		

### Reference Key

Symbol	Machining Conditions
●	Good - Main Application
◐	Average - Main Application
⚙	Difficult - Main Application

### Reference Key

Symbol	Insert Type
▼▼	Finishing - Main Application
▽▽	Finishing - Extended Application

Insert Form	Countersunk Screw		Torque Driver	Service Key	Technical Data	
					Torque	Key Size
161	115676	M2.5 x 0.45 x 5	415514	115590	1.2 Nm	T8
163	115673	M3.5 x 0.6 x 9	415510	115664	3.0 Nm	T15

# Insert Form 47





Cermet | Carbide

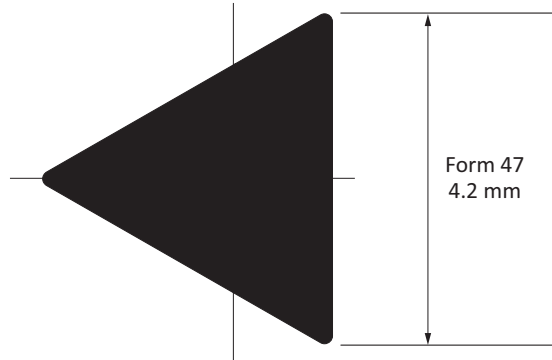

650 Geometry



						Carbide									
						Uncoated					Coated				
						WHW01	WHW16	WHC05	WHC18	WHC20	WHC79	WHC111	WHC114	WHC136	WHC164
Steel	P									▼▼▼					
Stainless Steel	M									▼▼▼					
Cast Iron	K					▼▼▼				▼▼▼					
Non-Ferrous Materials	N					▼▼▼									
Titanium	S					▼▼▼									
Hard Materials	H														
Geometry	Radius		ISO Code	Description	Part No.	WHW01	WHW16	WHC05	WHC18	WHC20	WHC79	WHC111	WHC114	WHC136	WHC164
	in	mm													
650	0.004	0.10	TOFX040101	F04701FL650	097832	●				●					
650	0.008	0.20	TOFX040102	F04702FL650	097833	●				●					

					Technical Data		
Insert Form	Countersunk Screw		Clamping Jaw	Torque Driver	Service Key	Torque	Key Size
47	315324	M1.8 x 0.35 x 4	315323	-	115537	0.5 Nm	T6

Reference Key

Symbol	Machining Conditions
●	Good - Main Application

Reference Key

Symbol	Insert Type
▼▼▼	Finishing - Main Application

A  
B  
C  
D  
E  
F  
G  
H  
I  
J  
K  
L  
M  
INDEX

## Insert Forms 101, 103, 104, 105

Cermet | Carbide

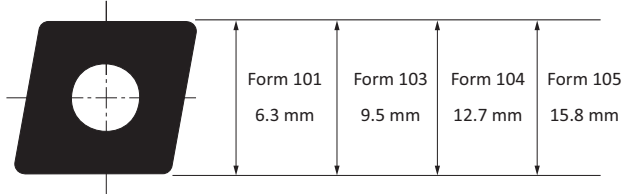
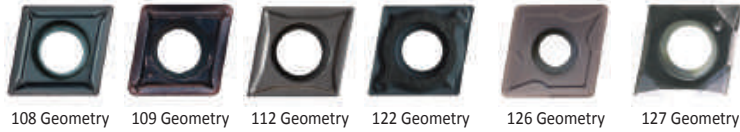

						Cermet						Carbide										
						Uncoated			Coated			Uncoated			Coated							
Steel P						▼▼▼			▼						▼▼▼			▼▼▼				
Stainless Steel M															▼▼▼			▼▼▼				
Cast Iron K						▼▼▼			▼▼▼			▼▼▼			▼▼▼			▼▼▼				
Non-Ferrous Materials N						▼▼▼			▼▼▼			▼▼▼			▼▼▼			▼▼▼				
Titanium S												▼▼▼			▼▼▼			▼▼▼				
Hard Materials H																						
Geometry	Radius		ISO Description	Description	Part No.	WHT10	WHT12	WHT16	WHT32	WTC15	WTC121	WHW01	WHW16	WHC05	WHC18	WHC19	WHC79	WHC98	WHC111	WHC114	WHC136	WHC164
	in	mm				WHT10	WHT12	WHT16	WHT32	WTC15	WTC121	WHW01	WHW16	WHC05	WHC18	WHC19	WHC79	WHC98	WHC111	WHC114	WHC136	WHC164
108	0.008	0.20	CCMT060202	F10102MN108	297833													●				
108	0.016	0.40	CCMT060204	F10104MN108	297537													●				
108	0.016	0.40	CCMT09T304	F10304MN108	297891													●				
108	0.031	0.80	CCMT09T308	F10308MN108	397118													●				
108	0.016	0.40	CCMT120404	F10404MN108	297725													●				
108	0.031	0.80	CCMT120408	F10408MN108	297724													●				
109	0.008	0.20	CCMT060202	F10102MN109	397352																	●
109	0.016	0.40	CCMT060204	F10104MN109	397765																	●
109	0.016	0.40	CCMT09T304	F10304MN109	397354																	●
109	0.031	0.80	CCMT09T308	F10308MN109	397355																	●
109	0.016	0.40	CCMT120404	F10404MN109	397356																	●
109	0.031	0.80	CCMT120408	F10408MN109	397357																	●
112	0.008	0.20	CCGT060202	F10102GN112	297485				●													
112	0.016	0.40	CCMT060204	F10104MN112	297434				●													
112	0.008	0.20	CCGT09T302	F10302GN112	297534				●													
112	0.016	0.40	CCMT09T304	F10304MN112	297387				●													
122	0.008	0.20	CCMT060202	F10102MN122	097899	●																
122	0.016	0.40	CCMT060204	F10104MN122	097926	●																
122	0.008	0.20	CCMT09T302	F10302MN122	097862	●																
122	0.016	0.40	CCMT09T304	F10304MN122	097957	●																
126	0.031	0.80	CCMT160508	F10508MN126	297557																	●
126	0.047	1.20	CCMT160512	F10512MN126	297558																	●
127	0.008	0.20	CCGT060202	F10102GN127	097529							●		●								
127	0.016	0.40	CCGT060204	F10104GN127	097445							●		●								
127	0.008	0.20	CCGT09T302	F10302GN127	297550							●		●								
127	0.016	0.40	CCGT09T304	F10304GN127	097497							●		●								
127	0.016	0.40	CCGT120404	F10404GN127	097496							●		●								

Reference Key

Symbol	Machining Conditions
●	Good - Main Application
●	Average - Main Application

Reference Key

Symbol	Insert Type
▼	Roughing - Main Application
▽	Roughing - Extended Application
▼▼▼	Finishing - Main Application
▽▽▽	Finishing - Extended Application

Insert Form	Countersunk Screw		Torque Driver	Service Key	Technical Data	
	Torque	Key Size				
101	115676	M2.5 x 0.45 x 5	415514	115590	1.2 Nm	T8
103	115672(<math>\phi</math>37mm)	M3.5 x 0.6 x 7.5	415510	115664	3.0 Nm	T15
103	115673(>math>\phi</math>36mm)	M3.5 x 0.6 x 9	415510	115664	3.0 Nm	T15
104	215149	M4.5 x 0.75 x 11.5	415543	215150	5.0 Nm	T20
105	215149	M4.5 x 0.75 x 11.5	415543	215150	5.0 Nm	T20



## Insert Forms 101, 103, 104, 105

Cermet | Carbide

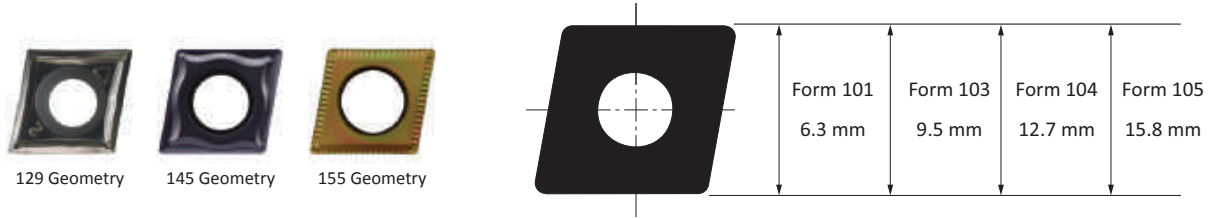

						Cermet						Carbide										
						Uncoated			Coated			Uncoated			Coated							
Material	Code					WHT10	WHT12	WHT16	WHT32	WTC15	WTC121	WHW01	WHW16	WHC05	WHC18	WHC19	WHC79	WHC98	WHC111	WHC114	WHC136	WHC164
Steel	P								▼▼▼				▼					▼▼▼				
Stainless Steel	M								▽▽▽				▽					▼▼▼				
Cast Iron	K								▽▽▽				▼	▼▼▼				▼▼▼				
Non-Ferrous Materials	N											▼▼▼		▼▼▼								
Titanium	S											▽▽▽		▼				▼▼▼				
Hard Materials	H																	▼▼▼				
Geometry	Radius		ISO Description	Description	Part No.	WHT10	WHT12	WHT16	WHT32	WTC15	WTC121	WHW01	WHW16	WHC05	WHC18	WHC19	WHC79	WHC98	WHC111	WHC114	WHC136	WHC164
129	0.002	0.05	CCGT0602005	F101005GN129	397738								●	●								
129	0.004	0.10	CCGT060201	F10101GN129	397737								●	●								
129	0.008	0.20	CCGT060202	F10102GN129	297545								●	●	●							
129	0.016	0.40	CCGT060204	F10104GN129	297546								●	●	●							
129	0.008	0.20	CCGT09T302	F10302GN129	297547								●	●	●							
129	0.016	0.40	CCGT09T304	F10304GN129	297548								●	●	●							
145	0.016	0.40	CCGT060204	F10104GN145	297980														●			
145	0.031	0.80	CCGT060208	F10108GN145	397742														●			
145	0.016	0.40	CCGT09T304	F10304GN145	297994														●			
145	0.031	0.80	CCGT09T308	F10308GN145	297995														●			
155	0.008	0.20	CCMT060202	F10102MN155	397662					●												
155	0.016	0.40	CCMT060204	F10104MN155	397739					●												
155	0.016	0.40	CCMT09T304	F10304MN155	397740					●												

Insert Form	Countersunk Screw		Torque Driver	Service Key	Technical Data	
	Part No.	Dimensions			Torque	Key Size
101	115676	M2.5 x 0.45 x 5	415514	115590	1.2 Nm	T8
103	115672(<math>\phi</math>37mm)	M3.5 x 0.6 x 7.5	415510	115664	3.0 Nm	T15
103	115673(>math>\phi</math>36mm)	M3.5 x 0.6 x 9	415510	115664	3.0 Nm	T15
104	215149	M4.5 x 0.75 x 11.5	415543	215150	5.0 Nm	T20
105	215149	M4.5 x 0.75 x 11.5	415543	215150	5.0 Nm	T20

### Reference Key

Symbol	Machining Conditions
●	Good - Main Application
◐	Average - Main Application

### Reference Key

Symbol	Insert Type
▼	Roughing - Main Application
▽	Roughing - Extended Application
▼▼▼	Finishing - Main Application
▽▽▽	Finishing - Extended Application

# Insert Forms 101, 103, 104, 105

Carbide

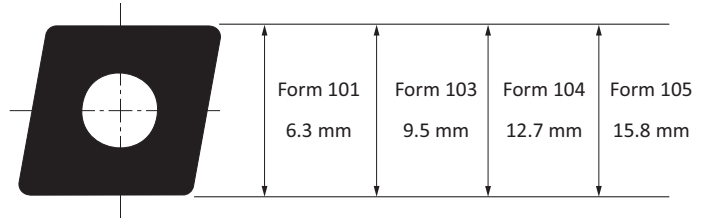

						Carbide										
						Uncoated					Coated					
						WHW01	WHW16	WHC05	WHC18	WHC19	WHC79	WHC98	WHC111	WHC114	WHC136	WHC164
Geometry	Radius		ISO Code	Description	Part No.											
	in	mm														
Steel	P					▽▽▽		▽		▽▽▽	▽▽▽		▽▽▽			▽▽▽
Stainless Steel	M						▽▽▽			▽▽▽			▽▽▽			
Cast Iron	K						▽▽▽		▽	▽▽▽			▽▽▽			▽▽▽
Non-Ferrous Materials	N															
Titanium	S								▽▽▽				▽▽▽			
Hard Materials	H												▽▽▽			▽▽▽
158	0.008	0.20	CCMT060202	F10102MN158	297248											
158	0.016	0.40	CCMT060204	F10104MN158	297377											
158	0.016	0.40	CCMT09T304	F10304MN158	297239											
158	0.031	0.80	CCMT09T308	F10308MN158	297240											
158	0.016	0.40	CCMT120404	F10404MN158	297242											
158	0.031	0.80	CCMT120408	F10408MN158	297241											
158	0.031	0.80	CCMT160508	F10508MN158	297559			●					●			
158	0.047	1.20	CCMT160512	F10512MN158	297560											
174W	0.016	0.40	CCMT060204	F10104MN174W	397766											●
174W	0.016	0.40	CCMT09T304	F10304MN174W	397767					⚙						●
174W	0.031	0.80	CCMT09T308	F10308MN174W	397768					⚙						●
192	0.008	0.20	CCMT060202	F10102MN192	297531											●
192	0.016	0.40	CCMT060204	F10104MN192	297658					⚙						●
192	0.031	0.80	CCMT060208	F10108MN192	297588					⚙						●
192	0.008	0.20	CCMT09T302	F10302MN192	297958					⚙						●
192	0.016	0.40	CCMT09T304	F10304MN192	297653					⚙						●
192	0.031	0.80	CCMT09T308	F10308MN192	397614					⚙						●
192	0.016	0.40	CCMT120404	F10404MN192	397666					⚙						●
192	0.031	0.80	CCMT120408	F10408MN192	297878					⚙						●
192	0.047	1.20	CCMT120412	F10412MN192	397632					⚙						●

Reference Key

Symbol	Machining Conditions
●	Good - Main Application
●	Average - Main Application
⚙	Difficult - Main Application

Reference Key

Symbol	Insert Type
▽	Roughing - Main Application
▽	Roughing - Extended Application
▽▽▽	Finishing - Main Application
▽▽▽	Finishing - Extended Application

Insert Form	Countersunk Screw		Torque Driver		Service Key		Technical Data	
	Torque	Key Size	Torque	Key Size	Torque	Key Size	Torque	Key Size
101	115676	M2.5 x 0.45 x 5	415514	115590	1.2 Nm	T8		
103	115672(<Ø37mm)	M3.5 x 0.6 x 7.5	415510	115664	3.0 Nm	T15		
103	115673(>Ø36mm)	M3.5 x 0.6 x 9	415510	115664	3.0 Nm	T15		
104	215149	M4.5 x 0.75 x 11.5	415543	215150	5.0 Nm	T20		
105	215149	M4.5 x 0.75 x 11.5	415543	215150	5.0 Nm	T20		

## Insert Forms 101, 103, 104, 105

Cermet | Carbide

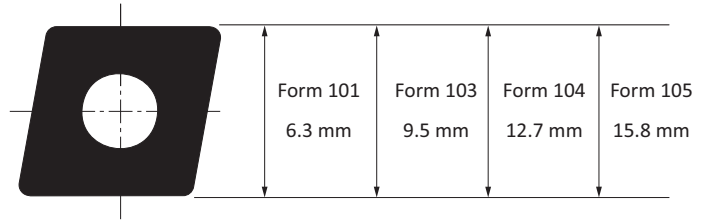
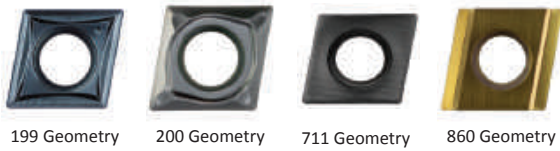

						Cermet						Carbide											
						Uncoated			Coated			Uncoated			Coated								
Material	ISO Code	Part No.				WHT10	WHT12	WHT16	WHT32	WTC15	WTC121	WHW01	WHW16	WHC05	WHC18	WHC19	WHC77	WHC79	WHC98	WHC111	WHC114	WHC136	WHC164
Steel	P									▼▼▼			▼▼▼			▼▼▼			▼▼▼	▼▼▼	▼▼▼	▼▼▼	▼▼▼
Stainless Steel	M									▽▽▽			▽▽▽			▽▽▽			▽▽▽	▽▽▽	▽▽▽	▽▽▽	▽▽▽
Cast Iron	K									▽			▼▼▼			▼▼▼			▼▼▼	▼▼▼	▼▼▼	▼▼▼	▼▼▼
Non-Ferrous Materials	N									▼▼▼													
Titanium	S																				▼▼▼	▼▼▼	▼▼▼
Hard Materials	H																▽▽▽			▼▼▼	▼▼▼	▼▼▼	▼▼▼
Geometry	Radius		ISO Code	Description	Part No.	WHT10	WHT12	WHT16	WHT32	WTC15	WTC121	WHW01	WHW16	WHC05	WHC18	WHC19	WHC77	WHC79	WHC98	WHC111	WHC114	WHC136	WHC164
199	0.008	0.20	CCMT060202	F10102MN199	397164																		
199	0.016	0.40	CCMT060204	F10104MN199	397165																●	●	
199	0.008	0.20	CCMT09T302	F10302MN199	397702																	●	
199	0.016	0.40	CCMT09T304	F10304MN199	397166																	●	
199	0.031	0.80	CCMT09T308	F10308MN199	397167																	●	
199	0.016	0.40	CCMT120404	F10404MN199	397191																	●	
199	0.031	0.80	CCMT120408	F10408MN199	397168																	●	
200	0.008	0.20	CCGT060202	F10102GN200	397585																●		
200	0.016	0.40	CCGT060204	F10104GN200	397586																●		
200	0.008	0.20	CCGT09T302	F10302GN200	397587																●		
200	0.016	0.40	CCGT09T304	F10304GN200	397588																●		
200	0.016	0.40	CCGT120404	F10404GN200	397589																●		
711	0.016	0.40	CCMT060204	F10104MN711	097637																		
711	0.016	0.40	CCMT09T304	F10304MN711	097692												●						
711	0.031	0.80	CCMT09T308	F10308MN711	297910												●						
711	0.031	0.80	CCMT120408	F10408MN711	297911												●						
860	0.004	0.10	CCGT060201	F10101GL860	097324						●	●		●									●
860	0.008	0.20	CCGT060202	F10102GL860	097241						●	●		●									●
860	0.016	0.40	CCGT060204	F10104GL860	097242						●	●		●									●
860	0.008	0.20	CCGT09T302	F10302GL860	097245						●	●		●									●
860	0.016	0.40	CCGT09T304	F10304GL860	097244						●	●		●									●
860	0.016	0.40	CCGT120404	F10404GL860	097738						●	●		●									●
860	0.031	0.80	CCGT120408	F10408GL860	097247						●	●		●									●
860	0.031	0.80	CCMT160508	F10508ML860	097249						●	●		●									●

### Reference Key

Symbol	Machining Conditions
●	Good - Main Application
●	Average - Main Application

### Reference Key

Symbol	Insert Type
▼	Roughing - Main Application
▽	Roughing - Extended Application
▼▼▼	Finishing - Main Application
▽▽▽	Finishing - Extended Application

Insert Form	Countersunk Screw		Torque Driver		Service Key		Technical Data	
	Part No.	Dimensions	Part No.	Part No.	Torque	Key Size		
101	115676	M2.5 x 0.45 x 5	415514	115590	1.2 Nm	T8		
103	115672(<math>\phi 37\text{mm}</math>)	M3.5 x 0.6 x 7.5	415510	115664	3.0 Nm	T15		
103	115673(>math>\phi 36\text{mm}</math>)	M3.5 x 0.6 x 9	415510	115664	3.0 Nm	T15		
104	215149	M4.5 x 0.75 x 11.5	415543	215150	5.0 Nm	T20		
105	215149	M4.5 x 0.75 x 11.5	415543	215150	5.0 Nm	T20		

### Insert Forms 101, 103, 104

Ceramic | CBN | PCD

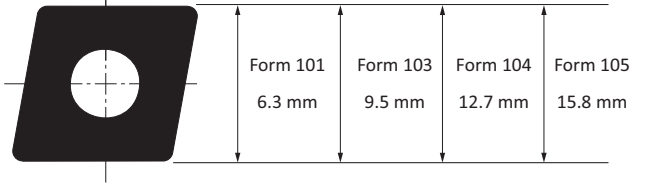
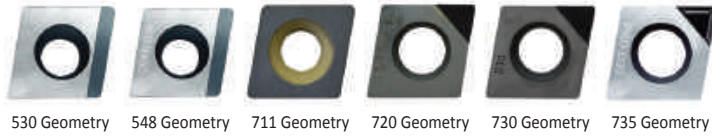

		Ceramic		CBN		PCD						
		Uncoated	Coated	Uncoated	Coated							
Steel	P											
Stainless Steel	M											
Cast Iron	K	▼		▼▼▼								
Non-Ferrous Materials	N					▼▼▼▼						
Titanium	S											
Hard Materials	H											
Geometry	Radius		ISO Code	Description	Part No.	WCN06	WBN150	WBN200	WBN300	WBN450	PKD030	PKD50
	in	mm										
530	0.016	0.40	CCGW060204	F10104GL530	397207						●	
530	0.016	0.40	CCGW060204	F10104GR530	397242						●	
530	0.016	0.40	CCGW09T304	F10304GL530	397249						●	
530	0.016	0.40	CCGW09T304	F10304GR530	397250						●	
548	0.016	0.40	CCGW060204	F10104GL548	397245					●		
548	0.016	0.40	CCGW060204	F10104GR548	397246					●		
548	0.016	0.40	CCGW09T304	F10304GL548	397604					●		
548	0.016	0.40	CCGW09T304	F10304GR548	397605					●		
711	0.016	0.40	CCGW09T304	F10304GN711	297561	⚙						
711	0.031	0.80	CCGW09T308	F10308GN711	297192	⚙						
711	0.031	0.80	CCGW120408	F10408GN711	297249	⚙						
711	0.047	1.20	CCGW120412	F10412GN711	297234	⚙						
720	0.008	0.20	CCGT060202	F10102GN720	297501						●	
720	0.016	0.40	CCGT060204	F10104GN720	297502						●	
720	0.008	0.20	CCGT09T302	F10302GN720	297578						●	
720	0.016	0.40	CCGT09T304	F10304GN720	297483						●	
730	0.008	0.20	CCGW060202	F10102GN730	097462						●	●
730	0.016	0.40	CCGW060204	F10104GN730	297164						●	●
730	0.031	0.80	CCGW060208	F10108GN730	297165						●	●
730	0.008	0.20	CCGW09T302	F10302GN730	397251						●	●
730	0.016	0.40	CCGW09T304	F10304GN730	297533						●	●
730	0.016	0.40	CCGW120404	F10404GN730	397257						●	●
730	0.031	0.80	CCGW120408	F10408GN730	297871						●	●
735	0.008	0.20	CCGT060202	F10102GN735	297872						●	
735	0.016	0.40	CCGT060204	F10104GN735	397244						●	
735	0.008	0.20	CCGT09T302	F10302GN735	397252						●	
735	0.016	0.40	CCGT09T304	F10304GN735	297870						●	

Reference Key

Symbol	Machining Conditions
●	Good - Main Application
●	Average - Main Application
⚙	Difficult - Main Application

Reference Key

Symbol	Insert Type
▼	Roughing - Main Application
▽	Roughing - Extended Application
▼▼▼	Finishing - Main Application
▽▽▽	Finishing - Extended Application

Insert Form	Countersunk Screw		Torque Driver	Service Key	Technical Data	
					Torque	Key Size
101	115676	M2.5 x 0.45 x 5	415514	115590	1.2 Nm	T8
103	115672 (<∅37mm)	M3.5 x 0.6 x 7.5	415510	115664	3.0 Nm	T15
103	115673 (>∅36mm)	M3.5 x 0.6 x 9	415510	115664	3.0 Nm	T15
104	215149	M4.5 x 0.75 x 11.5	415543	215150	5.0 Nm	T20

## Insert Forms 101, 103, 104

CBN

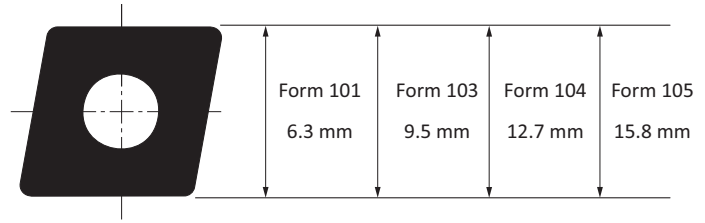
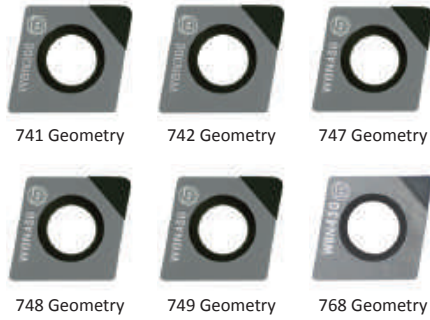

						CBN								
						Uncoated				Coated				
Steel						P								
Stainless Steel						M								
Cast Iron						K	▽▽▽	▽	▽▽▽	▽				
Non-Ferrous Materials						N								
Titanium						S								
Hard Materials						H	▽▽▽	▽	▽▽▽	▽				
Geometry	Radius		ISO Code	Description	Part No.	WBN150	WBN200	WBN300	WBN450					
	in	mm												
741	0.008	0.20	CCGW060202	F10102GN741	297290									
741	0.016	0.40	CCGW060204	F10104GN741	297291		●							
741	0.016	0.40	CCGW09T304	F10304GN741	297303		●							
742	0.008	0.20	CCGW060202	F10102GN742	297293			●						
742	0.016	0.40	CCGW060204	F10104GN742	297294			●						
742	0.016	0.40	CCGW09T304	F10304GN742	297306			●						
747	0.016	0.40	CCGW120404	F10404GN747	397260	●			●					
748	0.008	0.20	CCGW060202	F10102GN748	297787				●					
748	0.016	0.40	CCGW060204	F10104GN748	297788				●					
748	0.008	0.20	CCGW09T302	F10302GN748	297790				●					
748	0.016	0.40	CCGW09T304	F10304GN748	297419				●					
749	0.031	0.80	CCGW120408	F10408GN749	397261	●			●					
768	0.008	0.20	CCGT060202	F10102GN768	297486				●					
768	0.016	0.40	CCGT060204	F10104GN768	297659				●					
768	0.008	0.20	CCGT09T302	F10302GN768	397439				●					
768	0.016	0.40	CCGT09T304	F10304GN768	297660				●					

Insert Form	Countersunk Screw		Torque Driver		Service Key		Technical Data	
	Part No.	Dimensions	Part No.	Part No.	Torque	Key Size		
101	115676	M2.5 x 0.4 x 5	415514	115590	1.2 Nm	T8		
103	115672(<math>\phi 37\text{mm}</math>)	M3.5 x 0.6 x 7.5	415510	115664	3.0 Nm	T15		
103	115673(>math>\phi 36\text{mm}</math>)	M3.5 x 0.6 x 9	415510	115664	3.0 Nm	T15		
104	215149	M4.5 x 0.75 x 11.5	415543	215150	5.0 Nm	T20		

### Reference Key

Symbol	Machining Conditions
●	Good - Main Application
●	Average - Main Application

### Reference Key

Symbol	Insert Type
▽	Roughing - Main Application
▽	Roughing - Extended Application
▽▽▽	Finishing - Main Application
▽▽▽	Finishing - Extended Application

## Insert Forms 123, 124

Carbide

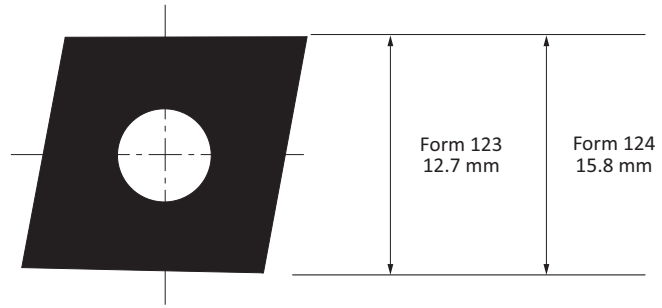

Carbide																			
						Uncoated							Coated						
Material	ISO Code					WHW01	WHW16	WHC05	WHC18	WHC79	WHC98	WHC111	WHC114	WHC136	WHC164	WHC190			
Steel	P											▽▽▽		▽▽▽	▽▽▽	▽▽▽			
Stainless Steel	M											▽▽▽		▽▽▽		▽▽▽			
Cast Iron	K											▽▽▽		▽▽▽	▽▽▽	▽▽▽			
Non-Ferrous Materials	N																		
Titanium	S											▽▽▽		▽▽▽		▽▽▽			
Hard Materials	H											▽▽▽		▽▽▽		▽▽▽			
Geometry	Radius		ISO Code	Description	Part No.	WHW01	WHW16	WHC05	WHC18	WHC79	WHC98	WHC111	WHC114	WHC136	WHC164	WHC190			
	in	mm																	
117	0.031	0.80	CNMG120408	F12308MN117	397683							●			●	●			
117	0.047	1.20	CNMG120412	F12312MN117	397777							●			●	●			
117	0.031	0.80	CNMG160608	F12408MN117	397608							●			●	●			
117	0.047	1.20	CNMG160612	F12412MN117	397778							●			●	●			
158	0.016	0.40	CNMG120404	F12304MN158	397799									●					
158	0.031	0.80	CNMG120408	F12308MN158	397800									●					
158	0.047	1.20	CNMG120412	F12312MN158	397801									●					
158	0.031	0.80	CNMG160608	F12408MN158	397802									●					
158	0.047	1.20	CNMG160612	F12412MN158	397803									●					
161	0.016	0.40	CNMG120404	F12304MN161	397758							●			●	●			
161	0.031	0.80	CNMG120408	F12308MN161	397759							●			●	●			
167	0.016	0.40	CNMG120404	F12304MN167	397756							●			●	●			
167	0.031	0.80	CNMG120408	F12308MN167	397757							●			●	●			

### Reference Key

Symbol	Machining Conditions
●	Good - Main Application
●	Average - Main Application
●	Difficult - Main Application

### Reference Key

Symbol	Insert Type
▽	Roughing - Main Application
▽	Roughing - Extended Application
▽▽▽	Finishing - Extended Application

Insert Form	Clamping Set		Mounting Arbor for Sleeve	Clamping Bolt		Service Key	
	Part No.	Key Size		Part No.	Key Size	Part No.	Key Size
123	315003	s3	415642	115775	s2.5	415578	s3
						115575	s2.5
124	315054	s3	415644	115776	s3	415578	s3
						115630	s3

### Insert Form 123

Ceramic | CBN | PCD

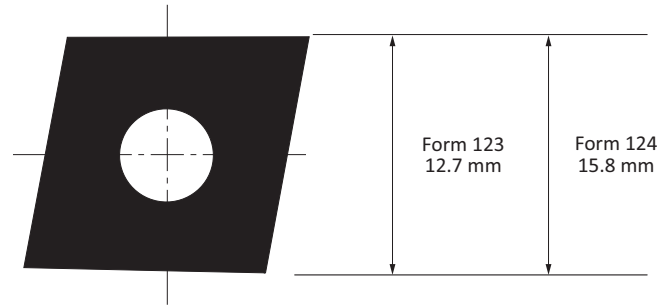

		Ceramic		CBN				PCD			
		Uncoated	Coated	Uncoated		Coated					
Steel	P										
Stainless Steel	M										
Cast Iron	K	▽		▽	▽	▽					
Non-Ferrous Materials	N							▽			
Titanium	S										
Hard Materials	H			▽							
Geometry	Radius	ISO Code	Description	Part No.	WCN06	WBN150	WBN200	WBN300	WBN450	PKDD30	PKDD50
711	0.031 / 0.80	CNGA120408	F12308GN711	397842	⚙️						
711	0.047 / 1.20	CNGA120412	F12312GN711	397843	⚙️						
730	0.031 / 0.80	CNGA120408	F12308GN730	397849						⚙️	
749	0.031 / 0.80	CNGA120408	F12308GN749	397262		⚙️		⚙️			

#### Reference Key

Symbol	Machining Conditions
⚙️	Average - Main Application
⚙️	Difficult - Main Application

#### Reference Key

Symbol	Insert Type
▽	Roughing - Main Application
▽	Roughing - Extended Application
▽▽	Finishing - Main Application
▽▽	Finishing - Extended Application

Insert Form	Clamping Set		Mounting Arbor for Sleeve	Clamping Bolt		Service Key	
	Part No.	Key Size	Part No.	Part No.	Key Size	Part No.	Key Size
123	315003	s3	415642	115775	s2.5	415578 115575	s3 s2.5

A  
B  
C  
D  
E  
F  
G  
H  
I  
J  
K  
L  
M  
INDEX

### Insert Form 39

Cermet | Carbide

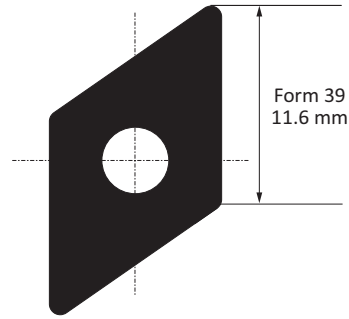

						Cermet						Carbide										
						Uncoated			Coated			Uncoated			Coated							
Material	ISO Code	Radius	ISO Code	Description	Part No.	WHT10	WHT12	WHT16	WHT32	WTC15	WTC121	WHW01	WHW16	WHC05	WHC18	WHC79	WHC98	WHC111	WHC114	WHC136	WHC164	WHC190
Steel	P	0.008	DCMT11T302	F03902MN121	397787					▼▼▼				▼▼▼				▼▼▼			▼▼▼	▼▼▼
Stainless Steel	M	0.016	DCMT11T304	F03904MN121	397788					▽▽▽				▽▽▽				▽▽▽			▽▽▽	▽▽▽
Cast Iron	K	0.008	DCGT11T302	F03902GN127	397235					▽▽▽			●	●				▼▼▼			▼▼▼	▼▼▼
Cast Iron	K	0.016	DCGT11T304	F03904GN127	097559					▽▽▽			●	●				▼▼▼			▼▼▼	▼▼▼
Cast Iron	K	0.008	DCGT11T302	F03902GN129	397816					●			●	●				▼▼▼			▼▼▼	▼▼▼
Cast Iron	K	0.016	DCGT11T304	F03904GN129	397817					●			●	●				▼▼▼			▼▼▼	▼▼▼
Non-Ferrous Materials	N	0.008	DCMT11T302	F03902MN155	397809					●								▼▼▼			▼▼▼	▼▼▼
Non-Ferrous Materials	N	0.016	DCMT11T304	F03904MN155	397810					●								▼▼▼			▼▼▼	▼▼▼
Titanium	S	0.008	DCMT11T302	F03902MN192	397783													▼▼▼			▼▼▼	▼▼▼
Titanium	S	0.016	DCMT11T304	F03904MN192	297721													▼▼▼			▼▼▼	▼▼▼
Titanium	S	0.031	DCMT11T308	F03908MN192	397784													▼▼▼			▼▼▼	▼▼▼
Hard Materials	H	0.008	DCMT11T302	F03902GN200	397785													●			●	●
Hard Materials	H	0.016	DCMT11T304	F03904GN200	397786													●			●	●

Reference Key

Symbol	Machining Conditions
●	Good - Main Application
◐	Average - Main Application
⚡	Difficult - Main Application

Reference Key

Symbol	Insert Type
▼	Roughing - Main Application
▽	Roughing - Extended Application
▼▼▼	Finishing - Main Application
▽▽▽	Finishing - Extended Application

Insert Form	Countersunk Screw		Torque Driver	Service Key	Technical Data	
39	115673	M3.5 x 0.6 x 9	414510	115664	Torque	Key Size
					3.0 Nm	T15



# Insert Form 39

CBN | PCD



730 Geometry    735 Geometry    747 Geometry

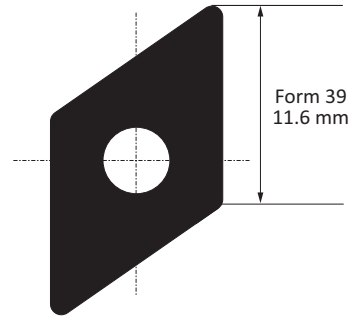

						CBN					PCD		
						Uncoated			Coated				
Steel		P											
Stainless Steel		M											
Cast Iron		K				▽▽			▽▽				
Non-Ferrous Materials		N										▽▽	
Titanium		S											
Hard Materials		H				▽▽							
Geometry	Radius		ISO Code	Description	Part No.	WBN150	WBN200	WBN300	WBN450	WBN200		PKDD30	PKDD50
730	0.008	0.20	DCGW11T302	F03902GN730	397269							●	
730	0.016	0.40	DCGW11T304	F03904GN730	397270							●	
735	0.008	0.20	DCGT11T302	F03902GN735	397271							●	
735	0.016	0.40	DCGT11T304	F03904GN735	397272							●	
747	0.008	0.20	DCGW11T302	F03902GN747	397273	●			●				
747	0.016	0.40	DCGW11T304	F03904GN747	397274	●			●				

Reference Key

Symbol	Machining Conditions
●	Average - Main Application
⊕	Difficult - Main Application

Reference Key

Symbol	Insert Type
▽	Roughing - Main Application
▽	Roughing - Extended Application
▽▽	Finishing - Main Application
▽▽	Finishing - Extended Application

Insert Form	Countersunk Screw		Torque Driver	Service Key	Technical Data	
					Torque	Key Size
39	115673	M3.5 x 0.6 x 9	414510	115664	3.0 Nm	T15

A  
B  
C  
D  
E  
F  
G  
H  
I  
J  
K  
L  
M  
INDEX

## Insert Form 75

Carbide



117 Geometry    158 Geometry    161 Geometry    167 Geometry

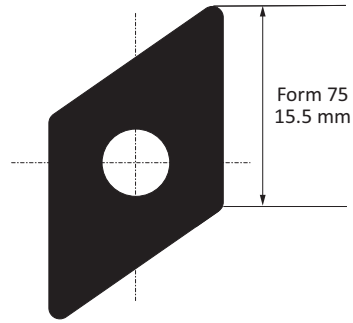

		Carbide													
		Uncoated					Coated								
Material	ISO Code	WHW01	WHW16	WHC05	WHC18	WHC79	WHC98	WHC111	WHC114	WHC136	WHC164	WHC190			
Steel	P							▽▽▽		▽▽	▽	▽▽	▽	▽▽	
Stainless Steel	M							▽▽▽		▽▽		▽▽		▽▽	
Cast Iron	K							▽▽▽		▽▽	▽	▽▽			
Non-Ferrous Materials	N														
Titanium	S							▽▽▽		▽▽				▽▽	
Hard Materials	H							▽▽▽			▽▽			▽	
Geometry	Radius	ISO Code	Description	Part No.	WHW01	WHW16	WHC05	WHC18	WHC79	WHC98	WHC111	WHC114	WHC136	WHC164	WHC190
117	0.031 / 0.80	DNMG150608	F07508MN117	397779										●	●
158	0.016 / 0.40	DNMG150604	F07504MN158	397804									●		
158	0.031 / 0.80	DNMG150608	F07508MN158	397805									●		
158	0.047 / 1.20	DNMG150612	F07512MN158	397806									●		
161	0.016 / 0.40	DNMG150604	F07504MN161	397746							●			●	●
161	0.031 / 0.80	DNMG150608	F07508MN161	397747							●			●	●
161	0.047 / 1.20	DNMG150612	F07512MN161	397748							●			●	●
167	0.016 / 0.40	DNMG150604	F07504MN167	397749							●			●	●
167	0.031 / 0.80	DNMG150608	F07508MN167	397750							●			●	●

### Reference Key

Symbol	Machining Conditions
●	Good - Main Application
●	Average - Main Application
●	Difficult - Main Application

### Reference Key

Symbol	Insert Type
▽	Roughing - Main Application
▽	Roughing - Extended Application
▽▽▽	Finishing - Extended Application

Insert Form	Clamping Set		Mounting Arbor for Sleeve	Service Key	
	Part No.	Key Size	Part No.	Part No.	Key Size
75	315004	s3	415642	415578	s3

# Insert Form 75

Ceramic | CBN | PCD



711 Geometry    730 Geometry    749 Geometry

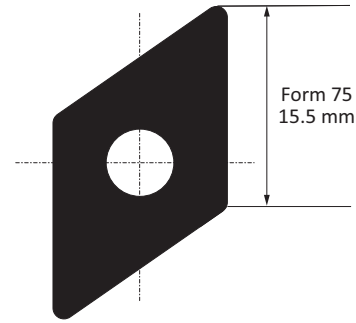

						Ceramic		CBN					PCD					
						Uncoated		Coated		Uncoated			Coated					
Steel						P												
Stainless Steel						M												
Cast Iron						K		▽▽▽		▽		▽▽▽						
Non-Ferrous Materials						N												
Titanium						S												
Hard Materials						H		▽▽▽		▽								
Geometry	Radius		ISO Code	Description	Part No.	WCN06			WBN150	WBN200	WBN300	WBN450	WBN200			PKDD30	PKDD50	
	in	mm																
711	0.031	0.80	DNGA150608	F07508GN711	397840	⚙												
711	0.047	1.20	DNGA150612	F07512GN711	397841	⚙												
730	0.031	0.80	DNGA150608	F07508GN730	397276										⚙			
749	0.031	0.80	DNGA150608	F07508GN749	397277				⚙			⚙						

### Reference Key

Symbol	Machining Conditions
⚙	Average - Main Application
⚙	Difficult - Main Application

### Reference Key

Symbol	Insert Type
▽	Roughing - Main Application
▽	Roughing - Extended Application
▽▽▽	Finishing - Main Application
▽▽▽	Finishing - Extended Application

Insert Form	Clamping Set		Mounting Arbor for Sleeve	Service Key	
	Part No.	Key Size	Part No.	Part No.	Key Size
75	315004	s3	415642	415578	s3

A  
B  
C  
D  
E  
F  
G  
H  
I  
J  
K  
L  
M  
INDEX

## Insert Forms 262, 264

Cermet | Carbide

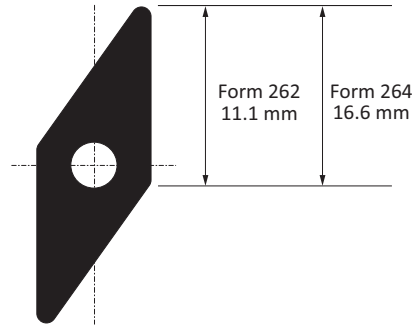

						Cermet					Carbide											
						Uncoated			Coated		Uncoated		Coated									
Material	ISO Code					WHT10	WHT12	WHT16	WHT32	WTC15	WTC121	WHW01	WHW16	WHC05	WHC18	WHC79	WHC98	WHC111	WHC114	WHC136	WHC164	WHC190
Steel	P									▼▼▼			▼				▼				▼	▼
Stainless Steel	M									▽▽▽			▽				▽				▽	▽
Cast Iron	K									▽▽▽			▽				▽				▽	▽
Non-Ferrous Materials	N												▼									
Titanium	S												▽▽									▼
Hard Materials	H																				▽▽	
Geometry	Radius	ISO Code	Description	Part No.																		
	in	mm																				
127	0.008	0.20	VCGT110302	F26202GN127	297146								●									
127	0.016	0.40	VCGT110304	F26204GN127	097954								●									
127	0.008	0.20	VCGT160402	F26402GN127	397813								●									
127	0.016	0.40	VCGT160404	F26404GN127	297900								●									
127	0.031	0.80	VCGT160408	F26408GN127	397179								●									
129	0.008	0.20	VCGT110302	F26202GN129	397811								●	●								
129	0.016	0.40	VCGT110304	F26204GN129	397812								●	●								
129	0.016	0.40	VCGT160404	F26404GN129	397814								●	●								
129	0.031	0.80	VCGT160408	F26408GN129	397815								●	●								
155	0.016	0.40	VCMT160404	F26404MN155	397807					●												
155	0.031	0.80	VCMT160408	F26408MN155	397808					●												
192	0.016	0.40	VCMT110304	F26204MN192	397628																●	●
192	0.031	0.80	VCMT110308	F26208MN192	397627																●	●
192	0.016	0.40	VCMT160404	F26404MN192	397611																●	●
192	0.031	0.80	VCMT160408	F26408MN192	397780																●	●
200	0.016	0.40	VCGT160404	F26404GN200	397782												●					
200	0.031	0.80	VCGT160408	F26408GN200	397781											●						

### Reference Key

Symbol	Machining Conditions
●	Good - Main Application
●	Average - Main Application
⚙	Difficult - Main Application

### Reference Key

Symbol	Insert Type
▼	Roughing - Main Application
▽	Roughing - Extended Application
▼▼▼	Finishing - Main Application
▽▽▽	Finishing - Extended Application

Insert Form	Countersunk Screw		Torque Driver	Service Key	Technical Data	
	Part No.	Size			Torque	Key Size
262	215987	M2.5 x 0.45 x 6	415514	115590	1.2 Nm	T8
264	115673	M3.5 x 0.6 x 9	415510	115664	3.0 Nm	T15

# Insert Forms 262, 264

CBN | PCD

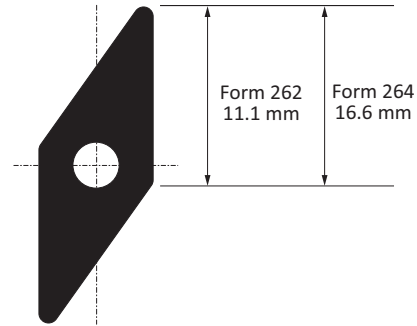

						CBN				PCD				
						Uncoated		Coated						
						WB150	WB200	WB300	WB450					
Steel	P													
Stainless Steel	M													
Cast Iron	K					▽▽▽			▽▽▽					
Non-Ferrous Materials	N											▽▽▽		
Titanium	S													
Hard Materials	H					▽▽▽								
Geometry	Radius	ISO Code	Description	Part No.								PKDD30	PKDD50	
	in	mm												
730	0.008	0.20	VCGW110302	F26202GN730	397284									
730	0.016	0.40	VCGW110304	F26204GN730	397285							●		
730	0.008	0.20	VCGW160402	F26402GN730	397407							●		
730	0.016	0.40	VCGW160404	F26404GN730	397278							●		
730	0.031	0.80	VCGW160408	F26408GN730	397279							●		
735	0.008	0.20	VCGW110302	F26202GN735	397818							●		
735	0.016	0.40	VCGW110304	F26204GN735	397286							●		
735	0.016	0.40	VCGT160404	F26404GN735	397280							●		
735	0.031	0.80	VCGT160408	F26408GN735	397281							●		
747	0.016	0.40	VCGW110304	F26204GN747	397287	●			●					
747	0.031	0.80	VCGW160408	F26408GN747	397283				●					
749	0.031	0.80	VCGW160408	F26408GN749	397282	●								

Reference Key

Symbol	Machining Conditions
●	Average - Main Application
⚙	Difficult - Main Application

Reference Key

Symbol	Insert Type
▽	Roughing - Extended Application
▽▽▽	Finishing - Main Application
▽▽▽	Finishing - Extended Application

Insert Form	Countersunk Screw		Torque Driver	Service Key	Technical Data	
					Torque	Key Size
262	215987	M2.5 x 0.45 x 6	415514	115590	1.2 Nm	T8
264	115673	M3.5 x 0.6 x 9	415510	115664	3.0 Nm	T15

A  
B  
C  
D  
E  
F  
G  
H  
I  
J  
K  
L  
M  
INDEX

## Insert Forms 112, 113, 114

Carbide

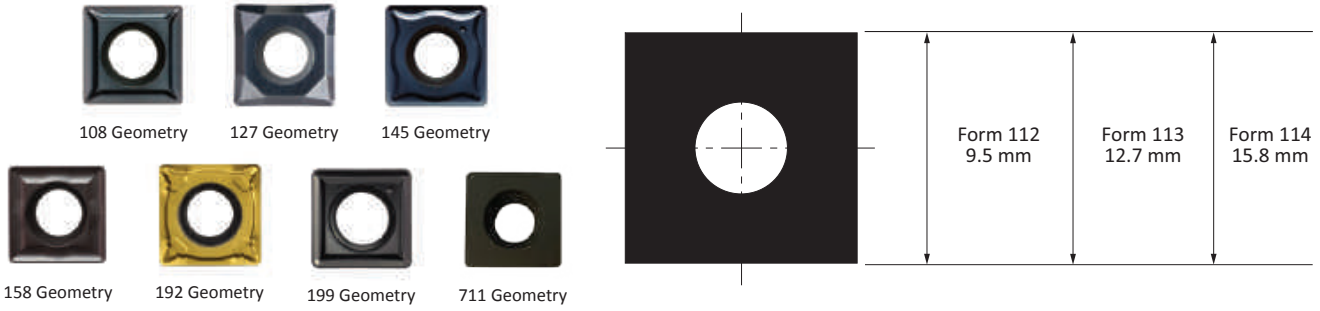

						Carbide											
						Uncoated			Coated								
						WHW01	WHW16	WHC05	WHC30	WHC77	WHC79	WHC98	WHC111	WHC114	WHC136	WHC164	WHC190
Steel	P					▽▽▽	▽	▽▽▽	▽▽▽	▽▽▽	▽▽▽	▽▽▽	▽▽▽	▽▽▽	▽▽▽	▽▽▽	▽▽▽
Stainless Steel	M					▽▽▽	▽	▽▽▽	▽▽▽	▽▽▽	▽▽▽	▽▽▽	▽▽▽	▽▽▽	▽▽▽	▽▽▽	▽▽▽
Cast Iron	K					▽▽▽	▽	▽▽▽	▽▽▽	▽▽▽	▽▽▽	▽▽▽	▽▽▽	▽▽▽	▽▽▽	▽▽▽	▽▽▽
Non-Ferrous Materials	N					▽▽▽	▽										
Titanium	S					▽▽▽	▽					▽▽▽	▽▽▽				▽▽▽
Hard Materials	H								▽▽▽	▽		▽▽▽	▽			▽▽▽	▽
Geometry	Radius		ISO Code	Description	Part No.	WHW01	WHW16	WHC05	WHC30	WHC77	WHC79	WHC98	WHC111	WHC114	WHC136	WHC164	WHC190
	in	mm															
108	0.016	0.40	SCMT09T304	F11204MN108	297535							●					
108	0.031	0.80	SCMT120408	F11308MN108	397110							●					
127	0.016	0.40	SCGT09T304	F11204GN127	097539		●										
127	0.016	0.40	SCGT120404	F11304GN127	397590		●										
127	0.031	0.80	SCGT120408	F11308GN127	097566		●										
145	0.031	0.80	SCGT09T308	F11208GN145	297996								●				
145	0.031	0.80	SCGT120408	F11308GN145	297997								●				
158	0.031	0.80	SCMT120408	F11308MN158	297497						●						
158	0.047	1.20	SCMT150512	F11412MN158	097252				●								
192	0.016	0.40	SCMT09T304	F11204MN192	397741											●	●
192	0.031	0.80	SCMT09T308	F11208MN192	397640											●	●
192	0.031	0.80	SCMT120408	F11308MN192	397709											●	●
192	0.047	1.20	SCMT120412	F11312MN192	397710											●	●
199	0.016	0.40	SCMT09T304	F11204MN199	397703									●			
199	0.031	0.80	SCMT09T308	F11208MN199	397704									●			
199	0.031	0.80	SCMT120408	F11308MN199	397705									●			
711	0.031	0.80	SCMT120408	F11308MN711	297212					●							

### Reference Key

Symbol	Machining Conditions
●	Good - Main Application
●	Average - Main Application
⚙	Difficult - Main Application

### Reference Key

Symbol	Insert Type
▽	Roughing - Main Application
▽	Roughing - Extended Application
▽▽▽	Finishing - Extended Application

Insert Form	Countersunk Screw		Torque Driver	Service Key	Technical Data	
	Torque	Key Size				
112	115672 (<math>\phi 37\text{mm}</math>)	M3.5 x 0.6 x 7.5	415510	115664	3.0 Nm	T15
112	115673 (>math>\phi 36\text{mm}</math>)	M3.5 x 0.6 x 9	415510	115664	3.0 Nm	T15
113	215149	M4.5 x 0.75 x 11.5	415543	215150	5.0 Nm	T20
114	215149	M4.5 x 0.75 x 11.5	415543	215150	5.0 Nm	T20

## Insert Forms 04, 05

Carbide



880 Geometry



811 Geometry

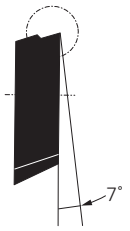
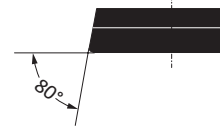
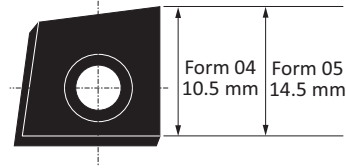

						Carbide										
						Uncoated					Coated					
Steel						P					▼	▼				
Stainless Steel						M					▽	▼				
Cast Iron						K					▼	▼				
Non-Ferrous Materials						N						▽				
Titanium						S						▽				
Hard Materials						H										
Geometry	Radius		ISO Code	Description	Part No.	WHW16	WHC05	WHC18	WHC19	WHC79	WHC98	WHC111	WHC114	WHC136	WHC168	WHC198
	in	mm														
880	0.016	0.40	-	F00404ML880	397595											●
880	0.016	0.40	-	F00504ML880	397593										⚙	●
880	0.031	0.80	-	F00508ML880	397594										⚙	●
811	0.031	0.80	-	F00508ML811	397844										⚙	

Insert Form	Countersunk Screw		Torque Driver	Service Key	Technical Data	
	Torque	Key Size				
04	415977	M4 x 0.7 x 7.9	415510	115664	3.0 Nm	T15
05	415949	M4 x 0.7 x 11	415543	215150	5.0 Nm	T20

### Reference Key

Symbol	Machining Conditions
●	Average - Main Application
⚙	Difficult - Main Application

### Reference Key

Symbol	Insert Type
▼	Roughing - Main Application
▽	Roughing - Extended Application

A  
B  
C  
D  
E  
F  
G  
H  
I  
J  
K  
L  
M  
INDEX

# Radial Grooving Insert Forms 89, 90, 91

Carbide

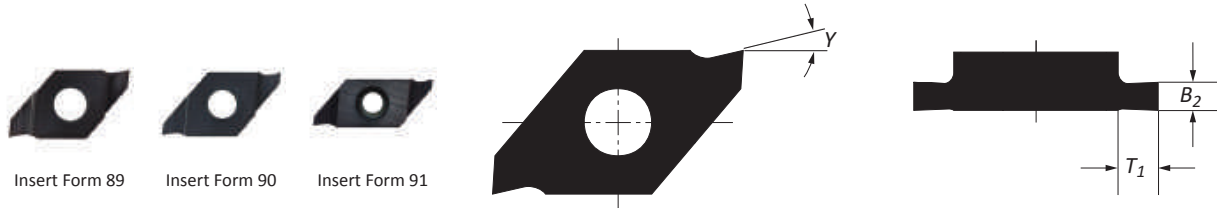

						Carbide											
						Uncoated			Coated								
Steel P																	▼
Stainless Steel M																	▽
Cast Iron K								▽									▼
Non-Ferrous Materials N								▼									
Titanium S								▽									▼
Hard Materials H																	
Insert Form	B <sub>2</sub>	Y	T <sub>1</sub>	Ring Width	Part No.	WHW01	WHW16	WHW20	WHC05	WHC18	WHC19	WHC79	WHC98	WHC111	WHC114	WHC136	WHC164
89	0.048	13°	0.051	0.039	097257			●									●
89	0.056	13°	0.051	0.047	097258			●									●
89	0.068	13°	0.059	0.059	097259			●									●
90	0.078	9°	0.094	0.068	097256			●									●
90	0.090	9°	0.094	0.078	097253			●									●
90	0.109	9°	0.094	0.098	097254			●									●
90	0.129	9°	0.094	0.118	097255			●									●
91	0.109	9°	0.094	0.098	097260			●									●
91	0.129	9°	0.094	0.118	097261			●									●
91	0.168	9°	0.129	0.157	097262			●									●
91	0.208	9°	0.177	0.196	097294			●									●
89	1.24	13°	1.30	1.00	097257			●									●
89	1.44	13°	1.30	1.20	097258			●									●
89	1.74	13°	1.50	1.50	097259			●									●
90	1.99	9°	2.40	1.75	097256			●									●
90	2.29	9°	2.40	2.00	097253			●									●
90	2.79	9°	2.40	2.50	097254			●									●
90	3.29	9°	2.40	3.00	097255			●									●
91	2.79	9°	2.40	2.50	097260			●									●
91	3.29	9°	2.40	3.00	097261			●									●
91	4.29	9°	3.30	4.00	097262			●									●
91	5.29	9°	4.50	5.00	097294			●									●

Insert Form	Countersunk Screw		Torque Driver	Service Key	Technical Data	
					Torque	Key Size
89	115676	M2.5 x 0.45 x 5	415514	115590	1.2 Nm	T8
90	115531	M3 x 0.5 x 7.5	415514	115590	1.2 Nm	T8
91	115802	M3 x 0.5 x 12	415514	115590	1.2 Nm	T8

Reference Key

Symbol	Machining Conditions
●	Average - Main Application

Reference Key

Symbol	Insert Type
▼	Universal - Main Application
▽	Universal - Extended Application

A  
B  
C  
D  
E  
F  
G  
H  
I  
J  
K  
L  
M  
INDEX



# Radial Grooving Insert Forms 89, 90, 91

Carbide

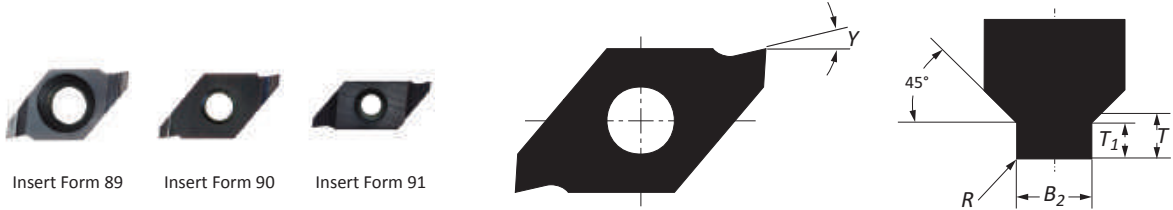

									Carbide													
									Uncoated						Coated							
									WHW01	WHW16	WHW20	WHC05	WHC18	WHC19	WHC79	WHC98	WHC111	WHC114	WHC136	WHC164		
Insert Form	Boring Ø	B <sub>2</sub>	Y	R	T <sub>1</sub>	T	Ring Width	Part No.														
Steel P																				▼▼		
Stainless Steel M																				▽▽		
Cast Iron K																				▼▼		
Non-Ferrous Materials N																						
Titanium S																				▼▼		
Hard Materials H																						
i	89	0.944 - 1.023	0.056	13°	0.004	0.021	0.025	0.047	297937													
	89	1.102 - 1.181	0.056	13°	0.004	0.025	0.029	0.047	297938												●	
	89	1.220 - 1.259	0.056	13°	0.004	0.030	0.035	0.047	297939												●	
	89	1.338	0.068	13°	0.004	0.030	0.035	0.059	297940												●	
	89	1.377 - 1.496	0.068	13°	0.004	0.036	0.041	0.059	297941												●	
	90	1.574 - 1.889	0.078	9°	0.006	0.046	0.051	0.068	297942													●
	90	1.968 - 2.480	0.090	9°	0.006	0.056	0.062	0.078	297943													●
	91	2.559 - 3.070	0.109	9°	0.008	0.056	0.062	0.098	297944													●
	91	3.149 - 3.228	0.109	9°	0.008	0.066	0.072	0.098	297945													●
	91	3.346 - 3.937	0.129	9°	0.008	0.066	0.072	0.118	297946													●
91	4.015 - 5.708	0.168	9°	0.008	0.076	0.084	0.157	297947													●	
m	89	24.00 - 26.00	1.44	13°	0.10	0.54	0.65	1.20	297937												●	
	89	28.00 - 30.00	1.44	13°	0.10	0.64	0.75	1.20	297938												●	
	89	31.00 - 32.00	1.44	13°	0.10	0.78	0.91	1.20	297939												●	
	89	34.00	1.74	13°	0.10	0.78	0.91	1.50	297940												●	
	89	35.00 - 38.00	1.74	13°	0.10	0.93	1.06	1.50	297941												●	
	90	40.00 - 48.00	1.99	9°	0.15	1.18	1.31	1.75	297942												●	
	90	50.00 - 63.00	2.29	9°	0.15	1.43	1.58	2.00	297943												●	
	91	65.00 - 78.00	2.79	9°	0.20	1.43	1.58	2.50	297944												●	
	91	80.00 - 82.00	2.79	9°	0.20	1.68	1.84	2.50	297945												●	
	91	85.00 - 100.00	3.29	9°	0.20	1.68	1.84	3.00	297946												●	
91	102.00 - 145.00	4.29	9°	0.20	1.94	2.14	4.00	297947												●		

Insert Form	Countersunk Screw		Torque Driver	Service Key	Technical Data	
	Part No.	Dimensions			Torque	Key Size
89	115676	M2.5 x 0.45 x 5	415514	115590	1.2 Nm	T8
90	115531	M3 x 0.5 x 7.5	415514	115590	1.2 Nm	T8
91	115802	M3 x 0.5 x 12	415514	115590	1.2 Nm	T8

Reference Key

Symbol	Machining Conditions
●	Average - Main Application

Reference Key

Symbol	Insert Type
▼▼	Universal - Main Application
▽▽	Universal - Extended Application

# Axial Grooving Insert Blanks Form 304

Carbide



			Carbide											
			Uncoated			Coated								
Material	Code		WHW01	WHW16	WHW20	WHC05	WHC18	WHC19	WHC79	WHC98	WHC111	WHC114	WHC136	WHC164
Steel	P													
Stainless Steel	M													
Cast Iron Non-Ferrous Materials	K				▽▽									
Non-Ferrous Materials	N				▼▼									
Titanium	S				▽▽									
Hard Materials	H													
Geometry	S <sub>1</sub>	Part No.	WHW01	WHW16	WHW20	WHC05	WHC18	WHC19	WHC79	WHC98	WHC111	WHC114	WHC136	WHC164
	0.137	297150			●									
	0.169	297151			●									
	0.208	297152			●									
	0.255	297154			●									
	0.295	297493			●									
	0.137	397850			●									
	0.169	397851			●									
	0.208	397852			●									
	0.255	397853			●									
	0.295	397854			●									
	3.50	297150			●									
	4.30	297151			●									
	5.30	297152			●									
	6.50	297154			●									
	7.50	297493			●									
	3.50	397850			●									
	4.30	397851			●									
	5.30	397852			●									
	6.50	397853			●									
	7.50	397854			●									

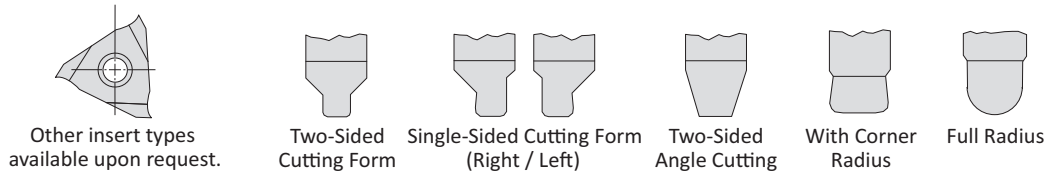

Reference Key

Symbol	Machining Conditions
●	Average - Main Application

Reference Key



Symbol	Insert Type
▼▼	Universal - Main Application
▽▽	Universal - Extended Application

				Technical Data	
Insert Form	Countersunk Screw	Torque Driver	Service Key	Torque	Key Size
304	215392 M5 x 0.8 x 12.9	415543	215150	5.0 Nm	T20

## Axial Grooving O-Rings for Single Cutter Tools Insert Form 304

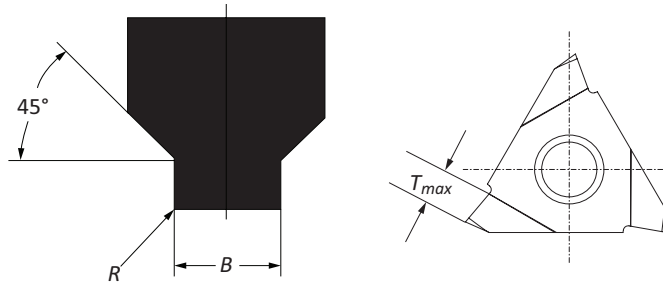
Carbide



								Carbide											
								Uncoated			Coated								
								WHW01	WHW16	WHW20	WHC05	WHC18	WHC19	WHC79	WHC98	WHC111	WHC114	WHC136	WHC164
Steel		P																▼	
Stainless Steel		M																▽	
Cast Iron Non-Ferrous Materials		K																▼	
Non-Ferrous Materials		N																	
Titanium		S																▼	
Hard Materials		H																	
Geometry	Boring Range	O-Ring Cross Section	$B + 0.05$	$B_{max}$	$T_{max}$	$R \pm 0.05$	Part No.	WHW01	WHW16	WHW20	WHC05	WHC18	WHC19	WHC79	WHC98	WHC111	WHC114	WHC136	WHC164
	0.787 - 2.125	0.039	0.059	0.059	0.064	0.008	297969												
	0.787 - 2.125	0.059	0.086	0.086	0.092	0.012	297970												●
	0.787 - 2.125	0.078	0.114	0.114	0.124	0.016	297971												●
	0.787 - 2.125	0.098	0.137	0.137	0.151	0.020	297972												●
	0.787 - 2.125	0.118	0.161	0.161	0.175	0.024	297973												●
	0.787 - 2.125	0.157	0.212	0.212	0.194	0.031	297974												
	20 - 54	1.00	1.50	1.50	1.65	0.20	297969												●
	20 - 54	1.50	2.20	2.20	2.35	0.30	297970												●
	20 - 54	2.00	2.90	2.90	3.15	0.40	297971												●
	20 - 54	2.50	3.50	3.50	3.85	0.50	297972												●
	20 - 54	3.00	4.10	4.10	4.45	0.60	297973												●
	20 - 54	4.00	5.40	5.40	4.95	0.80	297974												
20 - 54	5.00	6.80	6.80	4.95	0.80	297975													●

Reference Key

Symbol	Machining Conditions
●	Average - Main Application

Reference Key

Symbol	Insert Type
▼	Universal - Main Application
▽	Universal - Extended Application

Insert Form	Countersunk Screw		Torque Driver	Service Key	Technical Data	
	Torque	Key Size				
304	215392	M5 x 0.8 x 12.9	415543	215150	5.0 Nm	T20

A  
B  
C  
D  
E  
F  
G  
H  
I  
J  
K  
L  
M  
INDEX

## Axial Grooving O-Rings for Twin Cutter Tools Insert Form 304

Carbide

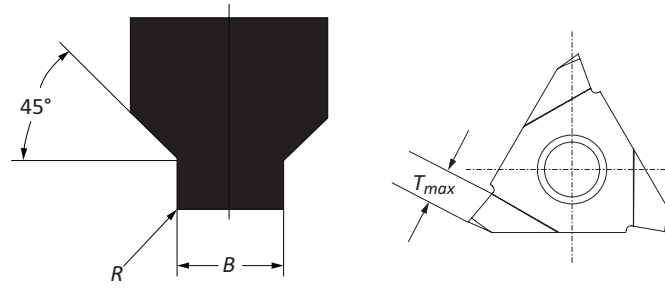

		Carbide																	
		Uncoated							Coated										
Material	Code	WHW01	WHW16	WHW20	WHC05	WHC18	WHC19	WHC79	WHC98	WHC111	WHC114	WHC136	WHC164	Symbol					
Steel	P													▼▼					
Stainless Steel	M													▽▽					
Cast Iron Non-Ferrous Materials	K													▼▼					
Non-Ferrous Materials	N																		
Titanium	S													▼▼					
Hard Materials	H																		
Geometry	Boring Range	O-Ring Cross Section	B + 0.05	B_max	T_max	R ± 0.05	Part No.	WHW01	WHW16	WHW20	WHC05	WHC18	WHC19	WHC79	WHC98	WHC111	WHC114	WHC136	WHC164
	2.086 - 39.37	0.039 - 0.059	0.059	0.098	0.064	0.008	297976												
	2.086 - 39.37	0.039 - 0.059	0.086	0.145	0.092	0.012	297977												●
	2.086 - 39.37	0.039 - 0.059	0.133	0.224	0.143	0.020	297978												●
	2.086 - 39.37	0.039 - 0.059	0.212	0.358	0.194	0.031	297979												●
	53.00 - 1000.00	1.00 - 1.50	1.50	2.50	1.65	0.20	297976												●
	53.00 - 1000.00	1.50 - 2.40	2.20	3.70	2.35	0.30	297977												●
	53.00 - 1000.00	2.40 - 4.00	3.40	5.70	3.65	0.50	297978												●
	53.00 - 1000.00	4.00 - 5.50	5.40	9.10	4.95	0.80	297979												●

### Reference Key

Symbol	Machining Conditions
●	Average - Main Application

### Reference Key



Symbol	Insert Type
▼▼	Universal - Main Application
▽▽	Universal - Extended Application

Insert Form	Countersunk Screw	Torque Driver	Service Key	Technical Data	
				Torque	Key Size
304	215392 M5 x 0.8 x 12.9	415543	215150	5.0 Nm	T20

# Insert Form 325

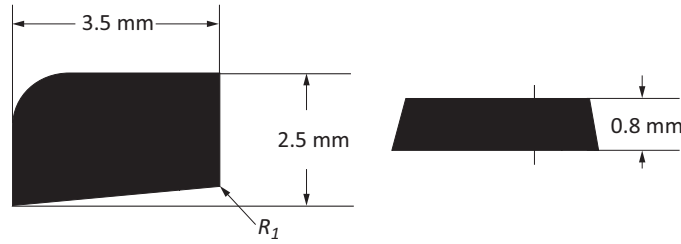
Carbide



				Carbide											
				Uncoated				Coated							
Material	Code			WHW01	WHW16	WHW20	WHC05	WHC18	WHC19	WHC79	WHC98	WHC111	WHC114	WHC136	WHC164
Steel	P													▼▼▼	
Stainless Steel	M													▼▼▼	
Cast Iron Non-Ferrous Materials	K					▼▼▼								▼▼▼	
Non-Ferrous Materials	N					▼▼▼									
Titanium	S													▼▼▼	
Hard Materials	H														
Geometry	Radius $R_1$	Description	Part No.	WHW01	WHW16	WHW20	WHC05	WHC18	WHC19	WHC79	WHC98	WHC111	WHC114	WHC136	WHC164
 860	0.004	F32501CN860	097831			●								●	
 860	0.10	F32501CN860	097831			●								●	

Insert Form	Countersunk Screw	Clamping Jaw	Torque Driver	Service Key	Technical Data	
					Torque	Key Size
325	315321 M1.6 x 0.35 x 3	315320	-	315322	0.3 Nm	0.5x3

Reference Key

Symbol	Machining Conditions
●	Average - Main Application

Reference Key

Symbol	Insert Type
▼▼▼	Finishing - Main Application
▼▼▼	Finishing - Extended Application

A  
B  
C  
D  
E  
F  
G  
H  
I  
J  
K  
L  
M  
INDEX

## Insert Accessories

Countersunk Screws | Torque Drivers

Insert Form	Countersunk Screw		Clamping Jaw	Torque Driver	Service Key	Technical Data	
						Torque	Key Size
04	<b>415977</b>	M4 x 0.7 x 7.9	–	<b>415510</b>	<b>115664</b>	3.0 Nm	T15
05	<b>415949</b>	M4 x 0.7 x 11	–	<b>415543</b>	<b>215150</b>	5.0 Nm	T20
20	<b>115535</b>	M2 x 0.4 x 5	–	<b>415508</b>	<b>115591</b>	0.9 Nm	T7
39	<b>115673</b>	M3.5 x 0.6 x 9	–	<b>414510</b>	<b>115664</b>	3.0 Nm	T15
47	<b>315324</b>	M1.8 x 0.35 x 4	<b>315323</b>	–	<b>115537</b>	0.5 Nm	T6
89	<b>115676</b>	M2.5 x 0.45 x 5	–	<b>415514</b>	<b>115590</b>	1.2 Nm	T8
90	<b>115531</b>	M3 x 0.5 x 7.5	–	<b>415514</b>	<b>115590</b>	1.2 Nm	T8
91	<b>115802</b>	M3 x 0.5 x 12	–	<b>415514</b>	<b>115590</b>	1.2 Nm	T8
101	<b>115676</b>	M2.5 x 0.45 x 5	–	<b>415514</b>	<b>115590</b>	1.2 Nm	T8
103	<b>115672(&lt;Ø37mm)</b>	M3.5 x 0.6 x 7.5	–	<b>415510</b>	<b>115664</b>	3.0 Nm	T15
103	<b>115673(&gt;Ø36mm)</b>	M3.5 x 0.6 x 9	–	<b>415510</b>	<b>115664</b>	3.0 Nm	T15
104	<b>215149</b>	M4.5 x 0.75 x 11.5	–	<b>415543</b>	<b>215150</b>	5.0 Nm	T20
105	<b>215149</b>	M4.5 x 0.75 x 11.5	–	<b>415543</b>	<b>215150</b>	5.0 Nm	T20
111	<b>115531</b>	M3 x 0.5 x 7.5	–	<b>415514</b>	<b>115590</b>	1.2 Nm	T8
112	<b>115672(&lt;Ø37mm)</b>	M3.5 x 0.6 x 7.5	–	<b>415510</b>	<b>115664</b>	3.0 Nm	T15
112	<b>115673(&gt;Ø36mm)</b>	M3.5 x 0.6 x 9	–	<b>415510</b>	<b>115664</b>	3.0 Nm	T15
113	<b>215149</b>	M4.5 x 0.75 x 11.5	–	<b>415543</b>	<b>215150</b>	5.0 Nm	T20
114	<b>215149</b>	M4.5 x 0.75 x 11.5	–	<b>415543</b>	<b>215150</b>	5.0 Nm	T20
161	<b>115676</b>	M2.5 x 0.45 x 5	–	<b>415514</b>	<b>115590</b>	1.2 Nm	T8
163	<b>115673</b>	M3.5 x 0.6 x 9	–	<b>415510</b>	<b>115664</b>	3.0 Nm	T15
211	<b>215377</b>	M2 x 0.4 x 4	–	<b>415507</b>	<b>115537</b>	0.6 Nm	T6
262	<b>215987</b>	M2.5 x 0.45 x 6	–	<b>415514</b>	<b>115590</b>	1.2 Nm	T8
264	<b>115673</b>	M3.5 x 0.6 x 9	–	<b>415510</b>	<b>115664</b>	3.0 Nm	T15
304	<b>215392</b>	M5 x 0.8 x 12.9	–	<b>415543</b>	<b>215150</b>	5.0 Nm	T20
325	<b>315321</b>	M1.6 x 0.35 x 3	<b>315320</b>	–	<b>315322</b>	0.3 Nm	0.5x3
394	<b>215915</b>	M2.5 x 0.45 x 7	–	<b>415514</b>	<b>115590</b>	1.1 Nm	T8
395	<b>215985</b>	M3 x 0.5 x 7.5	–	<b>415514</b>	<b>115590</b>	1.2 Nm	T8
396	<b>415320</b>	M3.5 x 0.6 x 11	–	<b>415510</b>	<b>115664</b>	3.0 Nm	T15
397	<b>215149</b>	M4.5 x 0.75 x 11.5	–	<b>415543</b>	<b>215150</b>	5.0 Nm	T20

## Insert Accessories

Countersunk Screws | Torque Drivers

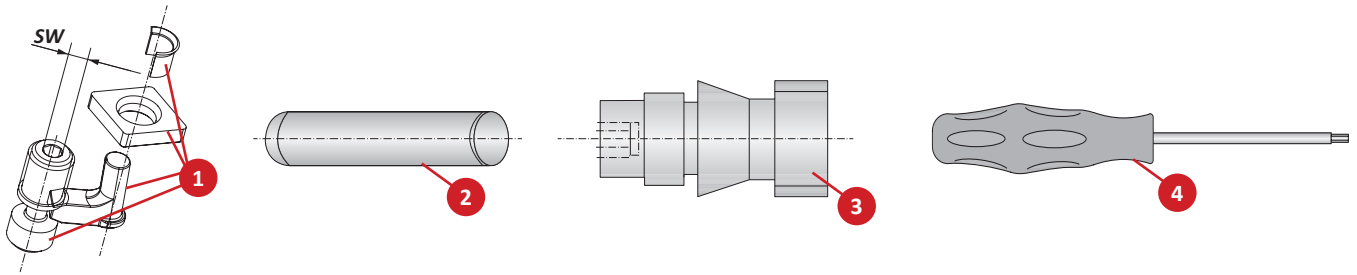

Insert Form	1. Clamping Set		2. Mounting Arbor for Sleeve		3. Clamping Bolt		4. Service Key	
	Part No.	Key Size	Part No.	Part No.	Key Size	Part No.	Key Size	
75	315004	s3	415642	-	-	415578	s3	
123	315003	s3	415642	115775	s2.5	415578 115575	s3 s2.5	
124	315054	s3	415644	115776	s3	415578 115630	s3 s3	

## Technical Information

### Surface Finish | General Formulas

The corner radius of replaceable inserts is very important in finish machining. Large corner radii (0.031" (0.8 mm) or higher allow for high feed rates with good surface quality.

The expected surface quality can be estimated by using the function of corner radius and feed rate formula.

	<p>1. The larger the corner radius and the lighter the feed rate is, the better the surface quality.</p>
	<p>2. If the feed is approximately 1/3 of the corner radius, the better the machining time and surface finish will be in finish machining applications.</p>
	<p>3. A larger corner radius increases radial forces, which can negatively affect dimensional accuracy. Large corner radii also require increased depth of cut.</p>



Minimum depth of cut ( $a_p$ ) should at least match the corner radius. This minimizes the radial forces.

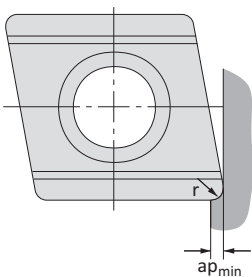

General Formulas		
Cutting Speed	$\frac{V_c = D \times \pi \times n}{1000}$	(m/min)
RPM	$\frac{n = V_c \times 1000}{D \times \pi}$	(min <sup>-1</sup> )
Feed Speed	$V_f = f \times n$	(mm/min)
	$D = \text{Machining } \varnothing$	(mm)
	$f = \text{Feed}$	(mm/u)
	$V_c = \text{Cutting Speed}$	(m/min)
	$n = \text{RPM}$	(min <sup>-1</sup> )



## Technical Information

### Wiper Geometries

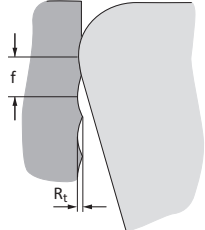
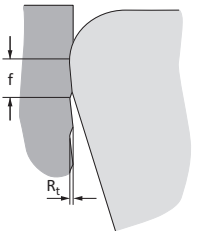
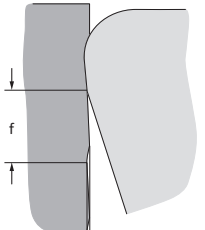
Replaceable Inserts with Wiper Geometry	
Insert with conventional corner radius with feed ( $f$ )	
Insert with wiper geometry radius with same feed ( $f$ )	
Insert with wiper geometry with increased feed ( $f$ )	

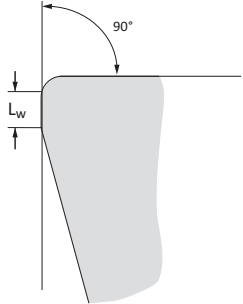
Wiper Geometry for 90° Approach Angle	
<p>Replaceable inserts produce a right-angled step at the bottom of the hole. When used in a Wohlhaupter standard insert holder that has a 90° approach angle, the secondary wiper cutting edge is nearly parallel with the wall of the hole.</p> <p>Wiper geometry for 90° approach angle  <math>L_w</math> = length of the wiper secondary cutting edge</p>	

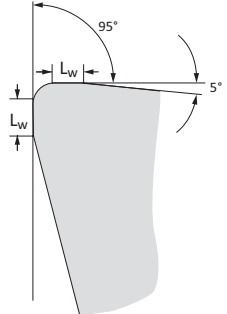
Wiper Geometry for 95° Approach Angle	
<p>Wiper inserts can also be used with 95° insert holders, which are included in the Wohlhaupter standard insert range.</p> <p>Wiper geometry for 95° approach angle (left and right cutting)  <math>L_w</math> = length of the secondary wiper cutting edge</p>	

A  
B  
C  
D  
E  
F  
G  
H  
I  
J  
K  
L  
M  
INDEX

## Boring Insert Wear Patterns

### Built-up Edge

#### Potential Problem

- Machined material adheres to the cutting edge of insert
- When it breaks, the edge becomes brittle and cracks
- This can negatively affect machined surface

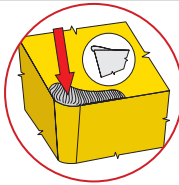

#### Possible Solution

- Increase temperature by increasing speed or feed
- Use an insert with higher lubricity coating
- Choose a freer cutting insert geometry

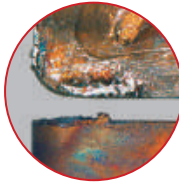

### Comb Cracks

#### Potential Problem

- Caused by high stress on the cutting edge during interrupted cuts

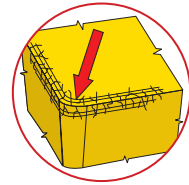

#### Possible Solution

- Switch off coolant or increase coolant flow to obtain an even temperature level
- Reduce cutting speed
- Use tougher insert grade

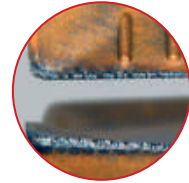

### Flank Wear

#### Potential Problem

- Caused by friction between the insert and machined material
- It cannot be fully eliminated, but it can be reduced

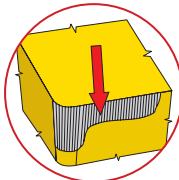

#### Possible Solution

- Use a more wear-resistant grade
- Reduce cutting speed
- Use coolant or increase coolant flow to the cutting edge

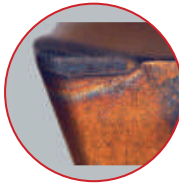

### Plastic Deformation

#### Potential Problem

- Caused by high thermal stress on the cutting edge from excessive feed rate and cutting speed

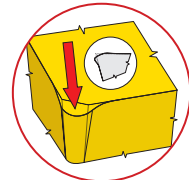

#### Possible Solution

- Use a more wear-resistant grade
- Reduce cutting speed
- Reduce feed rate
- Use coolant or increase coolant flow to the cutting edge

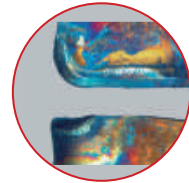

### Cratering

#### Potential Problem

- Appears when the geometry is too neutral or material is too hard for the substrate

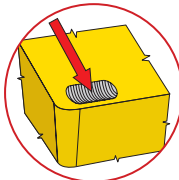

#### Possible Solution

- Use a more wear-resistant grade
- Reduce cutting speed or feed
- Use coolant or increase coolant flow to the cutting edge

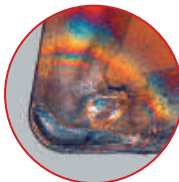

### Chipping of Cutting Edge (Out of Cut)

#### Potential Problem

- Caused by poor chip control
- Can damage the portion of the cutting edge that might not be engaged in the cut

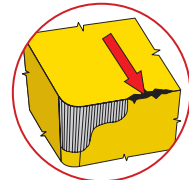

#### Possible Solution

- Change feed rate to gain chip control
- Select a tool with a different approach angle
- Use an insert with a different geometry
- Use a tougher grade of carbide

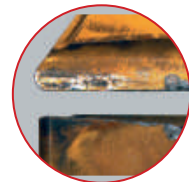

### Notch Wear

#### Potential Problem

- Occurs when cutting edge of insert comes in contact with surface of machined material
- Caused by hardening of surface layer of material and burrs
- Often appears on stainless austenitic steels and other high-temperature alloy steels

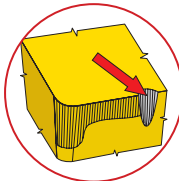

#### Possible Solution

- Use a more wear-resistant grade (Al<sub>2</sub>O<sub>3</sub>)
- Select a tool with a smaller approach angle
- Vary the radial depth of cut
- Use coolant or increase coolant flow to the cutting edge

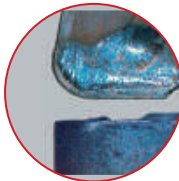

### Insert Fracture

#### Potential Problem

- Caused by workpiece material, grade, condition, the rigidity of the machine-tool workpiece, extent of wear, and cutting conditions

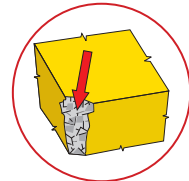

#### Possible Solution

- Use a tougher grade of carbide
- Reduce the feed and depth of cut
- Use an insert with a stronger chip breaker
- Use an insert with a bigger corner radius

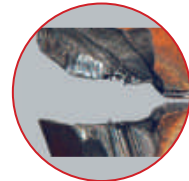



# Guaranteed Test / Demo Application Form

Distributor PO # \_\_\_\_\_

The following must be filled out completely before your test will be considered

**IMPORTANT:** For processing, send Purchase Order to your Allied Field Sales Engineer (FSE). Please clearly mark the paperwork as "Test Order."

## Distributor Information

Company Name: \_\_\_\_\_  
 Contact: \_\_\_\_\_  
 Account Number: \_\_\_\_\_  
 Phone: \_\_\_\_\_  
 Email: \_\_\_\_\_

## End User Information

Company Name: \_\_\_\_\_  
 Contact: \_\_\_\_\_  
 Industry: \_\_\_\_\_  
 Phone: \_\_\_\_\_  
 Email: \_\_\_\_\_

**Current Process** List all tooling, coatings, substrates, speeds and feeds, tool life, and any problems you are experiencing

\_\_\_\_\_

\_\_\_\_\_

**Test Objective** List what would make this a successful test (i.e. penetration rate, finish, tool life, hole size, etc.)

\_\_\_\_\_

\_\_\_\_\_

## Application Information

Hole Diameter: _____ in/mm	Tolerance: _____	Material: _____ (4150 / A36 / Cast Iron / etc.)
Preexisting Diameter: _____ in/mm	Depth of Cut: _____ in/mm	Hardness: _____ (BHN / Rc)
Required Finish: _____ RMS	State: _____	(Casting / Hot rolled / Forging)

## Machine Information

Machine Type: _____ (Lathe / Screw machine / Machine center / etc.)	Builder: _____ (Haas, Mori Seiki, etc.)	Model #: _____
Shank Required: _____ (CAT50 / Morse taper, etc.)		Power: _____ HP/KW
Rigidity: _____	Orientation: _____	Tool Rotating: _____
<input type="checkbox"/> Excellent	<input type="checkbox"/> Vertical	<input type="checkbox"/> Yes
<input type="checkbox"/> Good	<input type="checkbox"/> Horizontal	<input type="checkbox"/> No
<input type="checkbox"/> Poor		Thrust: _____ lbs/N

## Coolant Information

Coolant Delivery: _____ (Through tool / Flood)	Coolant Pressure: _____ PSI / bar
Coolant Type: _____ (Air mist, oil, synthetic, water soluble, etc.)	Coolant Volume: _____ GPM / LPM

## Requested Tooling

QTY	Item Number

QTY	Item Number



**Allied Machine & Engineering**  
 120 Deeds Drive  
 Dover, OH 44622

Telephone: (330) 343-4283  
 Toll Free USA & Canada: (800) 321-5537  
 Fax: (330) 602-3400  
 Email: info@alliedmachine.com

## Warranty Information



Allied Machine & Engineering ("Allied Machine") warrants to original equipment manufacturers, distributors, industrial and commercial users of its products for one year from the original date of sale that each new product manufactured or supplied by Allied Machine shall be free from defects in material and workmanship.

Allied Machine's sole and exclusive obligation under this warranty is limited to, at its option, without additional charge, replacing or repairing this product or issuing a credit. For this warranty to be applied, the product must be returned freight prepaid to the plant designated by an Allied Machine representative and which, upon inspection, is determined by Allied Machine to be defective in material and workmanship.

Complete information as to operating conditions, machine, setup, and the application of cutting fluid should accompany any product returned for inspection. This warranty shall not apply to any Allied Machine products which have been subjected to misuse, abuse, improper operating conditions, improper machine setup or improper application of cutting fluid or which have been repaired or altered if such repair or alteration, in the judgement of Allied Machine, would adversely affect the performance of the product.

THIS WARRANTY IS IN LIEU OF ALL OTHER WARRANTIES, EXPRESS OR IMPLIED, INCLUDING ANY IMPLIED WARRANTY OF MERCHANTABILITY OR FITNESS FOR A PARTICULAR PURPOSE. Allied Machine shall have no liability or responsibility for any claim, whether in contract, tort or otherwise, for any loss or damage arising out of, connected with, or resulting from the manufacture, sale, delivery or use of any product sold hereunder, in excess of the cost of replacement or repair as provided herein.

Allied Machine shall not be liable in contract or in tort (including, without limitation, negligence, strict liability or otherwise) for economic losses of any kind or for any special, incidental, indirect, consequential, punitive or exemplary damages arising in any way out of the performance of, or failure to perform this agreement.

ALL PRICES, DELIVERIES, DESIGNS, AND MATERIALS ARE SUBJECT TO CHANGE WITHOUT NOTICE.



Allied Machine & Engineering  
is registered to  
ISO 9001:2015 by DQS



Wohlhaupter GmbH  
is registered to  
ISO 9001:2015 by QA TECHNICH

## Deutschland | Österreich | Schweiz

**Wohlhaupter GmbH**  
Maybachstraße 4  
72636 Frickenhausen  
Germany

**Telefon:**  
+49 (0) 7022 408-0  
**Email:**  
info@wohlhaupter.de  
**Web:**  
www.wohlhaupter.com

## Europa

**Allied Machine & Engineering Co. (Europe) Ltd.**  
93 Vantage Point  
Pensnett Estate  
Kingswinford  
West Midlands  
DY6 7FR England

**Telefon:**  
+44 (0) 1384 400900  
**Email:**  
enquiries.eu@alliedmachine.com  
**Web:**  
www.alliedmachine.com

## Vereinigte Staaten

**Allied Machine & Engineering**  
120 Deeds Drive  
Dover OH 44622  
United States

**Telefon:**  
+1 330 343 4283  
**Fax:**  
+1 330 602 3400

**Allied Machine & Engineering**  
485 W Third Street  
Dover OH 44622  
United States

**Telefon:**  
+1 330 343 4283  
**Fax:**  
+1 330 364 7666  
(Engineering Dept.)

## Asien

**Wohlhaupter India Pvt. Ltd.**  
B-23, 2nd Floor  
B Block Community Centre  
Janakpuri, New Delhi - 110058  
India

**Telefon:**  
+91 11 41827044



台北: 02-27030193  
台中: 04-24636890

Website: [www.gcarbide.com](http://www.gcarbide.com)

**www.wohlhaupter.com**

90200 06.2018  
Printed in Germany - Technische Änderungen vorbehalten

Holemaking Solutions for Today's Manufacturing