



# ALLIED MACHINE & ENGINEERING

Holemaking Solutions for Today's Manufacturing



Drilling



Reaming



Burnishing



Threading



Specials



## Wohlhaupter®

► *BORING*

Fine Boring Tools

**WOHLHAUPTER®**



SECTION

---

# B10-B

---

Fine Boring

# Wohlhaupter® Fine Boring

420 (410) | 465 (464) | 365 (364) | 565 (564) | 320 (310) | 538 (537)

► **Diameter Range:** 0.787" - 8.071" (20.00 mm - 205.00 mm)



**NOTE:** Imperial items pictured  
**NOTE:** Adjustment accuracy of 0.0001" or 0.002 mm on diameter

## Boring has never been more exciting.

Wohlhaupter's fine boring systems are offered in both vernier and easy-to-read digital readout boring heads and cassettes. The lightweight Alu-Line serrated tool bodies reduce weight on the machine spindle.

### Unbalanced & Balanced Digital 3E<sup>TECH</sup> Boring Heads

- 420 (410) / 465 (464) fine boring heads
- 420 (410)  $\varnothing$  0.787" - 1.142" (20.00 mm - 29.00 mm)
- 465 (464)  $\varnothing$  1.142" - 8.071" (29.00 mm - 205.00 mm)

### Balanced Analog Boring Heads

- 365 (364) / 465 (464) fine boring heads
- 365 (364)  $\varnothing$  0.787" - 1.161" (20.00 mm - 29.50 mm)
- 465 (464)  $\varnothing$  1.142" - 8.071" (29.00 mm - 205.00 mm)

### Balanced Digital Boring Heads

- 565 (564) fine boring heads
- $\varnothing$  1.969" - 8.071" (50.00 mm - 205.00 mm)

### Unbalanced Analog Boring Heads

- 320 (310) fine boring heads
- $\varnothing$  0.787" - 8.071" (20.00 mm - 205.00 mm)

### Analog and Digital Cassettes

- 538 (537) fine boring cassettes
- $\varnothing$  3.937" - 8.071" (100.00 mm - 205.00 mm)

### Applicable Industries



Aerospace



Agriculture



Automotive



Firearms



General  
Machining



Oil & Gas



Renewable  
Energy

Your safety and the safety of others is very important. This catalog contains important safety messages. Always read and follow all safety precautions.



This triangle is a safety hazard symbol. It alerts you to potential safety hazards that can cause tool failure and serious injury.

When you see this symbol in the catalog, look for a related safety message that may be near this triangle or referred to in the nearby text.

There are safety signal words also used in the catalog. Safety messages follow these words.

#### **WARNING**

**WARNING** (shown above) means that failure to follow the precautions in this message could result in tool failure and serious injury.

**NOTICE** means that failure to follow the precautions in this message could result in damage to the tool or machine but not result in personal injury.

**NOTE** and **IMPORTANT** are also used. These are important that you read and follow but are not safety-related.

Visit [www.alliedmachine.com](http://www.alliedmachine.com) for the most up-to-date information and procedures.



# Fine Boring Table of Contents

## Reference Icons

The following icons will appear throughout the catalog to help you navigate between products.

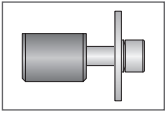

### Clamping Elements

For use with insert holders and boring heads

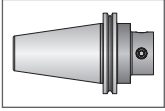

### Shanks

A variety of shanks for different machines

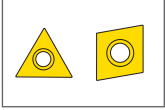

### Inserts

For use with insert holder boring heads and boring bars using indexable inserts

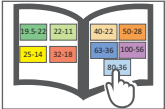

### MVS Connection Color Guide

Detailed instructions and information regarding the MVS connection(s)

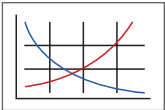

### Recommended Cutting Data

Speed and feed recommendations for optimum and safe boring



### Coolant-Through Option

Indicates that the product is coolant through

## Digital 3E<sup>TECH</sup> 420 (410) / 465 (464)

Product Overview	2 - 3
Unbalanced 420 (410) Boring Heads	4
Balanced 465 (464) Boring Heads	5 - 7
Insert Holders	8
Accessories	9

## Balanced Analog 365 (364) / 465 (464)

Product Overview	10 - 11
Boring Heads	12 - 13
Insert Holders	14
Accessories	15

## Balanced Digital 565 (564)

Product Overview	16 - 17
Boring Heads	18 - 19
Insert Holders	20
Accessories	21

## Unbalanced Analog 320 (310)

Product Overview	22 - 23
Boring Heads	24 - 25
Insert Holders	26
Accessories	27

## 538 (537) Cassettes

Product Overview	28 - 29
Analog Cassettes	30
3E <sup>TECH</sup> Digital Cassettes	31
Serrated Tool Bodies   Insert Holders	32
3E <sup>TECH</sup> Accessories	33

Series	Diameter Range	
	Imperial (inch)	Metric (mm)
420 (410)	0.787 - 1.142	20.00 - 29.00
465 (464)	1.142 - 8.071	29.00 - 205.00
365 (364)	0.787 - 1.161	20.00 - 29.50
565 (564)	1.969 - 8.071	50.00 - 205.00
320 (310)	0.787 - 8.071	20.00 - 205.00
538 (537)	3.937 - 8.071	100.00 - 205.00

# 420 (410) and 465 (464) Product Overview

## Digital 3E<sup>TECH</sup> 420 (410) and 465 (464) FINE BORING

Make easy diameter adjustments with our 3E<sup>TECH</sup> digital readout module.

Wohlhaupter® 420 (410) and 465 (464) digital boring heads are equipped with a 3E<sup>TECH</sup> docking port for easy digital adjustments. Boring heads from 1.142" (29.00 mm) and up offer precision boring with automatic balancing. Our boring heads are specifically engineered to minimize the residual imbalance produced by insert holder displacement. Wohlhaupter Alu-Line boring heads, ranging from 2.559" (65.00 mm) and up, offer a lightweight aluminum design with a wear-resistant coating that reduces weight on the spindle up to 50%. The insert holder can also be rotated for reverse machining jobs.

- Unbalanced 420 (410) diameter range: 0.787" - 1.142" (20.00 mm - 29.00 mm)
- Balanced 465 (464) diameter range: 1.142" - 8.071" (29.00 mm - 205.00 mm)
- Balanced 465 (464) Alu-Line diameter range: 2.559" - 8.071" (65.00 mm - 205.00 mm)
  - Special coating on Alu-Line for wear-resistant surface
  - Alu-Line body reduces tool weight by 50%, reducing stress on the spindle
- Coolant through
- 3E<sup>TECH</sup> and vernier diameter adjustment of 0.0001" (0.002 mm)
- Internal balancing improves tool life and surface finish
- Insert holder can be rotated for back boring jobs
- Max cutting speed: 5,577 SFM (1,700 m/min)

Highly accurate adjustments through vernier scale



NOTE: Imperial items pictured

NOTE: Adjustment accuracy of 0.0001" or 0.002 mm on diameter

Versatile 3E<sup>TECH</sup> digital readout compatible with other boring tools

**IMPORTANT:** Max spindle speed refers to maximum possible speed for an individual boring head and is not a recommended parameter. Refer to page B10-M: 12 for recommended application-specific parameters. Factory technical assistance is available for your specific applications through our Application Engineering department.  
ext: 7611 | email: [appeng@alliedmachine.com](mailto:appeng@alliedmachine.com)

# WOHLHAUPTER® 420 (410) and 465 (464) 3E<sup>TECH</sup> DIGITAL BORING HEADS

## Wohlhaupter 3E<sup>TECH</sup>

Improve productivity and quality with the Wohlhaupter 3E<sup>TECH</sup> external digital readout module. The 3E<sup>TECH</sup> docks onto boring heads and cassettes that offer the 3E<sup>TECH</sup> port to make easy diameter adjustments at the machine.

- Make quick and easy micron-accurate diameter adjustments
- Easy-to-read digital display shows exact diameter adjustments
- Designed to be removed from boring tool before operation (if forgotten 3E<sup>TECH</sup> will fall off at 500 RPM)
- Adjustments of 0.0001" (0.002 mm) on diameter
- Available in imperial and metric
- Water and dust resistant IP 56
- Coolant and chip resistant
- 3E<sup>TECH</sup> will automatically turn off after 30 seconds of not using
- WEEE-Reg.-Nr. DE 15820388

- ✓ High-production fine boring
- ✓ Easy diameter adjustment with 3E<sup>TECH</sup>
- ✓ Self-balancing 465 (464) boring heads
- ✓ Imperial and metric

NEW 420 (410) & 465 (464) BORING HEADS WITH 3E <sup>TECH</sup>		
	Diameter Range	Part No.
i	0.787 - 0.965	420001
	0.965 - 1.142	420002
	1.142 - 1.496	465003
	1.496 - 1.969	465004
	1.969 - 2.579	465005
	2.559 - 3.268	465006
	3.228 - 4.055	465007
	3.937 - 5.118	465008
	4.921 - 6.594	465009
	6.398 - 8.071	465010
m	20.00 - 24.50	410001
	24.50 - 29.00	410002
	29.00 - 38.00	464003
	38.00 - 50.00	464004
	50.00 - 65.50	464005
	65.00 - 83.00	464006
	82.00 - 103.00	464007
	100.00 - 130.00	464008
	125.00 - 167.50	464009
	162.50 - 205.00	464010



NOTE: Imperial items pictured

**IMPORTANT:** Max spindle speed refers to maximum possible speed for an individual boring head and is not a recommended parameter. Refer to page B10-M: 12 for recommended application-specific parameters. Factory technical assistance is available for your specific applications through our Application Engineering department.  
ext: 7611 | email: [appeng@alliedmachine.com](mailto:appeng@alliedmachine.com)



## 420 (410) Unbalanced Boring Heads with 3E<sup>TECH</sup>

Diameter Range: 0.787" - 1.142" (20.00 mm - 29.00 mm)



Form 101

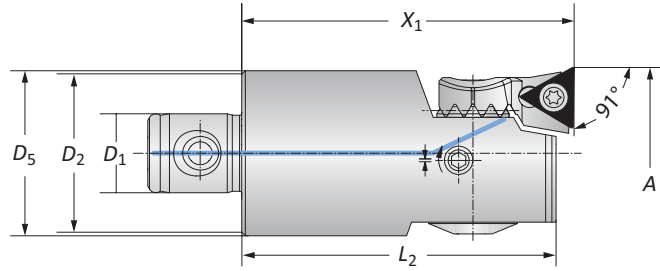

Form 20

### 420 Unbalanced Boring Heads with 3E<sup>TECH</sup>

MVS Connection	Boring Range	Boring Head				Weight	Insert Form	Part No.	
		$D_2$   $D_1$	A	$X_1$	$L_2$			$D_5$	Insert Holder
<b>i</b> 19 - 11	0.787 - 0.965		1.811	1.693	–	0.198 (lbs)	20*	364077	420001
<b>i</b> 22 - 11	0.965 - 1.142		1.811	1.713	0.906	0.286 (lbs)	20	210059	420002
<b>i</b> 22 - 11	0.965 - 1.142		1.811	1.713	0.906	0.286 (lbs)	101	210069	420002

\*Not suitable for indexable inserts with a radius of 0.031" (0.80 mm)

**NOTE:** 3E<sup>TECH</sup> module, insert holders, and inserts sold separately

### 410 Unbalanced Boring Heads with 3E<sup>TECH</sup>

MVS Connection	Boring Range	Boring Head				Weight	Insert Form	Part No.	
		$D_2$   $D_1$	A	$X_1$	$L_2$			$D_5$	Insert Holder
<b>m</b> 19 - 11	20.00 - 24.50		46.00	43.00	–	0.09 (kg)	20*	364077*	410001
<b>m</b> 22 - 11	24.50 - 29.00		46.00	43.50	23.00	0.13 (kg)	20	210059	410002
<b>m</b> 22 - 11	24.50 - 29.00		46.00	43.50	23.00	0.13 (kg)	101	210069	410002

\*Not suitable for indexable inserts with a radius of 0.031" (0.80 mm)

**NOTE:** 3E<sup>TECH</sup> module, insert holders, and inserts sold separately



### 3E<sup>TECH</sup> Digital Readout Module

Part No.	
<b>i</b>	563010
<b>m</b>	536010

**NOTE:** WEEE-Reg.-Nr. DE 15820388

**NOTE:** 3E<sup>TECH</sup> sold separately

**NOTE:** Imperial item pictured

**NOTE:** Adjustment accuracy of 0.0001" or 0.002 mm on diameter

B10-M: 12-15

B10-F

B10: vi-vii

**i** = Imperial (in)  
**m** = Metric (mm)

**IMPORTANT:** Max spindle speed refers to maximum possible speed for an individual boring head and is not a recommended parameter. Refer to page B10-M: 12 for recommended application-specific parameters. Factory technical assistance is available for your specific applications through our Application Engineering department.  
ext: 7611 | email: [appeng@alliedmachine.com](mailto:appeng@alliedmachine.com)

### 465 (464) Balanced Boring Heads with 3E<sup>TECH</sup>

Diameter Range: 1.142" - 2.579" (29.00 mm - 65.50 mm)



Form 101

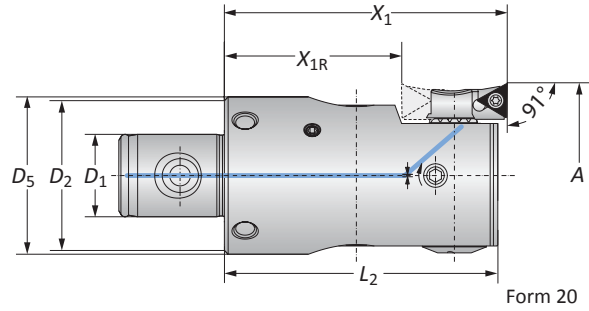

Form 20

#### 465 Balanced Boring Heads with 3E<sup>TECH</sup>

	MVS Connection		Boring Range				Boring Head			Part No.	
	$D_2$   $D_1$	A	$X_1$	$X_{1R}$	$L_2$	$D_5$	Weight	Insert Form	Insert Holder	Boring Head	
i	25 - 14	1.142 - 1.496	2.205	-	2.106	1.063	0.463 (lbs)	20	210059	465003	
	25 - 14	1.142 - 1.496	2.205	-	2.106	1.063	0.463 (lbs)	101	210069	465003	
	32 - 18	1.496 - 1.969	2.598	1.496	2.500	1.339	0.904 (lbs)	20	264051	465004	
	32 - 18	1.496 - 1.969	2.598	1.496	2.500	1.339	0.904 (lbs)	101	264077	465004	
	40 - 22	1.969 - 2.579	2.953	1.850	2.854	1.654	1.764 (lbs)	20	210052	465005	
	40 - 22	1.969 - 2.579	2.953	1.850	2.854	1.654	1.764 (lbs)	101	210062	465005	

NOTE:  $X_{1R}$  = rotated insert holder for reverse machining  
 NOTE: 3E<sup>TECH</sup> module, insert holders, and inserts sold separately

#### 464 Balanced Boring Heads with 3E<sup>TECH</sup>

	MVS Connection		Boring Range				Boring Head			Part No.	
	$D_2$   $D_1$	A	$X_1$	$X_{1R}$	$L_2$	$D_5$	Weight	Insert Form	Insert Holder	Boring Head	
m	25 - 14	29.00 - 38.00	56.00	-	53.50	27.00	0.21 (kg)	20	210059	464003	
	25 - 14	29.00 - 38.00	56.00	-	53.50	27.00	0.21 (kg)	101	210069	464003	
	32 - 18	38.00 - 50.00	66.00	38.00	63.50	34.00	0.41 (kg)	20	264051	464004	
	32 - 18	38.00 - 50.00	66.00	38.00	63.50	34.00	0.41 (kg)	101	264077	464004	
	40 - 22	50.00 - 65.50	75.00	47.00	72.50	42.00	0.80 (kg)	20	210052	464005	
	40 - 22	50.00 - 65.50	75.00	47.00	72.50	42.00	0.80 (kg)	101	210062	464005	

NOTE:  $X_{1R}$  = rotated insert holder for reverse machining  
 NOTE: 3E<sup>TECH</sup> module, insert holders, and inserts sold separately



#### 3E<sup>TECH</sup> Digital Readout Module

Part No.	
i	563010
m	536010

NOTE: WEEE-Reg.-Nr. DE 15820388  
 NOTE: 3E<sup>TECH</sup> sold separately

NOTE: Imperial item pictured  
 NOTE: Adjustment accuracy of 0.0001" or 0.002 mm on diameter

B10-M: 12-15

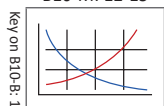

B10-F

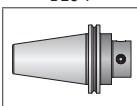

B10: vi-vii



i = Imperial (in)  
 m = Metric (mm)

**IMPORTANT:** Max spindle speed refers to maximum possible speed for an individual boring head and is not a recommended parameter. Refer to page B10-M: 12 for recommended application-specific parameters. Factory technical assistance is available for your specific applications through our Application Engineering department.  
 ext: 7611 | email: [appeng@alliedmachine.com](mailto:appeng@alliedmachine.com)



### 465 Balanced Boring Heads with 3E<sup>TECH</sup>

Imperial | Alu-Line | Diameter Range: 2.559" - 8.071"



Form 101

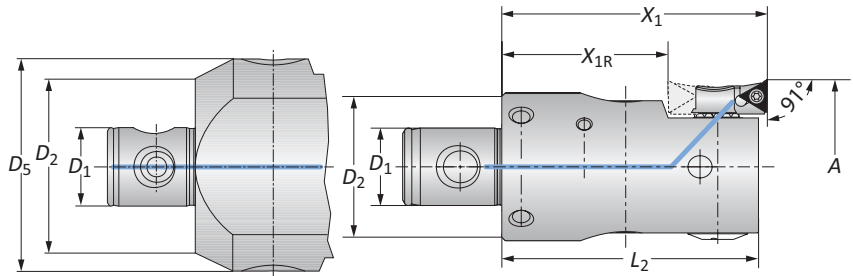

Form 20

### 465 Balanced Alu-Line Boring Heads with 3E<sup>TECH</sup>

MVS Connection	Boring Range	Boring Head					Weight	Insert Form	Part No.	
		$D_2   D_1$	A	$X_1$	$X_{1R}$	$L_2$			$D_5$	Insert Holder
	50 - 28	2.559 - 3.268	2.953	1.535	2.874	-	1.323 (lbs)	20	210020	465006
	50 - 28	2.559 - 3.268	2.953	1.535	2.874	-	1.323 (lbs)	101	210063	465006
	50 - 28	2.559 - 3.268	2.953	1.535	2.874	-	1.323 (lbs)	103	210064	465006
	63 - 36	3.228 - 4.055	3.543	2.126	3.464	-	2.205 (lbs)	20	210020	465007
	63 - 36	3.228 - 4.055	3.543	2.126	3.464	-	2.205 (lbs)	101	210063	465007
	63 - 36	3.228 - 4.055	3.543	2.126	3.464	-	2.205 (lbs)	103	210064	465007
	80 - 36	3.937 - 5.118	3.543	2.126	3.464	-	3.307 (lbs)	20	210020	465008
<b>i</b>	80 - 36	3.937 - 5.118	3.543	2.126	3.464	-	3.307 (lbs)	101	210063	465008
	80 - 36	3.937 - 5.118	3.543	2.126	3.464	-	3.307 (lbs)	103	210064	465008
	80 - 36	4.921 - 6.594	3.543	2.126	3.464	3.937	3.307 (lbs)	20	210020	465009
	80 - 36	4.921 - 6.594	3.543	2.126	3.464	3.937	4.189 (lbs)	101	210063	465009
	80 - 36	4.921 - 6.594	3.543	2.126	3.464	3.937	4.189 (lbs)	103	210064	465009
	80 - 36	6.398 - 8.071	3.543	2.126	3.464	5.315	4.189 (lbs)	20	210020	465010
	80 - 36	6.398 - 8.071	3.543	2.126	3.464	5.315	4.189 (lbs)	101	210063	465010
	80 - 36	6.398 - 8.071	3.543	2.126	3.464	5.315	5.512 (lbs)	103	210064	465010

**NOTE:**  $X_{1R}$  = rotated insert holder for reverse machining  
**NOTE:** 3E<sup>TECH</sup> module, insert holders, and inserts sold separately



#### 3E<sup>TECH</sup> Digital Readout Module

Part No.
<b>i</b> 563010

**NOTE:** WEEE-Reg.-Nr. DE 15820388  
**NOTE:** 3E<sup>TECH</sup> sold separately

**NOTE:** Imperial item pictured  
**NOTE:** Adjustment accuracy of 0.0001" or 0.002 mm on diameter

B10-M: 12-15 | B10-F | B10: vi-vii

**i** = Imperial (in)  
**m** = Metric (mm)

**IMPORTANT:** Max spindle speed refers to maximum possible speed for an individual boring head and is not a recommended parameter. Refer to page B10-M: 12 for recommended application-specific parameters. Factory technical assistance is available for your specific applications through our Application Engineering department.  
 ext: 7611 | email: [appeng@alliedmachine.com](mailto:appeng@alliedmachine.com)



### 464 Balanced Boring Heads with 3E<sup>TECH</sup>

Metric | Alu-Line | Diameter Range: 65.00 mm - 205.00 mm



Form 101

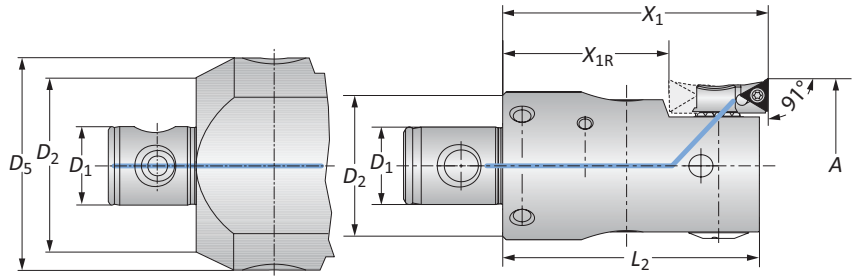

Form 20

### 464 Balanced Alu-Line Boring Heads with 3E<sup>TECH</sup>

MVS Connection	Boring Range	Boring Head					Weight	Insert Form	Part No.	
		$D_2   D_1$	A	$X_1$	$X_{1R}$	$L_2$			$D_5$	Insert Holder
m	50 - 28	65.00 - 83.00	75.00	39.00	73.00	-	0.60 (kg)	20	210020	464006
	50 - 28	65.00 - 83.00	75.00	39.00	73.00	-	0.60 (kg)	101	210063	464006
	50 - 28	65.00 - 83.00	75.00	39.00	73.00	-	0.60 (kg)	103	210064	464006
	63 - 36	82.00 - 103.00	90.00	54.00	88.00	-	1.00 (kg)	20	210020	464007
	63 - 36	82.00 - 103.00	90.00	54.00	88.00	-	1.00 (kg)	101	210063	464007
	63 - 36	82.00 - 103.00	90.00	54.00	88.00	-	1.00 (kg)	103	210064	464007
	80 - 36	100.00 - 130.00	90.00	54.00	88.00	-	1.50 (kg)	20	210020	464008
	80 - 36	100.00 - 130.00	90.00	54.00	88.00	-	1.50 (kg)	101	210063	464008
	80 - 36	100.00 - 130.00	90.00	54.00	88.00	-	1.50 (kg)	103	210064	464008
	80 - 36	125.00 - 167.50	90.00	54.00	88.00	100.00	1.90 (kg)	20	210020	464009
	80 - 36	125.00 - 167.50	90.00	54.00	88.00	100.00	1.90 (kg)	101	210063	464009
	80 - 36	125.00 - 167.50	90.00	54.00	88.00	100.00	1.90 (kg)	103	210064	464009
	80 - 36	162.50 - 205.00	90.00	54.00	88.00	135.00	2.50 (kg)	20	210020	464010
	80 - 36	162.50 - 205.00	90.00	54.00	88.00	135.00	2.50 (kg)	101	210063	464010
	80 - 36	162.50 - 205.00	90.00	54.00	88.00	135.00	2.50 (kg)	103	210064	464010

NOTE:  $X_{1R}$  = rotated insert holder for reverse machining  
 NOTE: 3E<sup>TECH</sup> module, insert holders, and inserts sold separately



#### 3E<sup>TECH</sup> Digital Readout Module

Part No.
m 536010

NOTE: WEEE-Reg.-Nr. DE 15820388  
 NOTE: 3E<sup>TECH</sup> sold separately

NOTE: Imperial item pictured  
 NOTE: Adjustment accuracy of 0.0001" or 0.002 mm on diameter

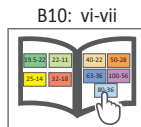
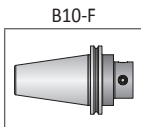
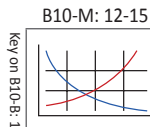

i = Imperial (in)  
 m = Metric (mm)

**IMPORTANT:** Max spindle speed refers to maximum possible speed for an individual boring head and is not a recommended parameter. Refer to page B10-M: 12 for recommended application-specific parameters. Factory technical assistance is available for your specific applications through our Application Engineering department.  
 ext: 7611 | email: [appeng@alliedmachine.com](mailto:appeng@alliedmachine.com)

## Insert Holders for Abrasive Materials

Diameter Range: 2.559" - 8.071" (65.00 mm - 205.00 mm)

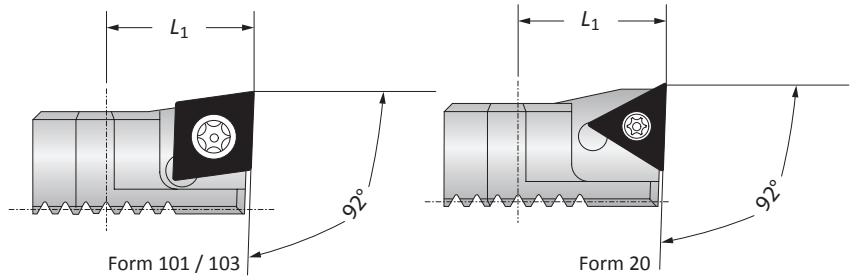

		Insert Holder			
Boring Range		$L_1$	Weight	Insert Form	Part No.
i	2.559 - 8.071	0.709	0.066 (lbs)	20	211061
	2.559 - 8.071	0.709	0.066 (lbs)	101	211063
	2.559 - 8.071	0.709	0.066 (lbs)	103	211065
m	65.00 - 205.00	18.00	0.03 (kg)	20	211061
	65.00 - 205.00	18.00	0.03 (kg)	101	211063
	65.00 - 205.00	18.00	0.03 (kg)	103	211065

**NOTE:** Insert holders used for abrasive materials to protect boring head against chip wash

**NOTE:** When machining grey cast iron, we recommend using insert holders for abrasive materials with CBN inserts for optimized chip removal.

B10-M: 12-15

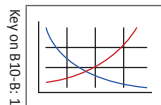

B10-H

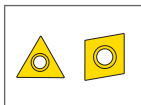

B10: vi-vii

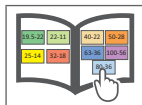

Key on B10-B: 1

i = Imperial (in)  
m = Metric (mm)

Inserts sold separately

Accessories

Screws | 3E<sup>TECH</sup> Accessories

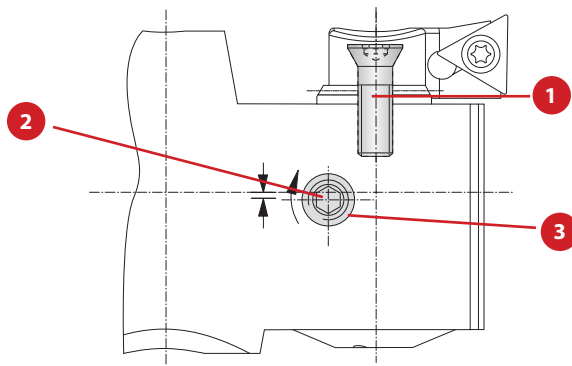

Boring Head	Part No.				
	1 Countersunk Screw	Countersunk Screw Service Key	2 Clamping Screw	Clamping Screw Service Key	3 Ball
420001 (410001)	215323	T15 / H	410151	S2 / A	364270
420002 (410002)	215338	T15 / H	410152	s2 / A	364270
465003 (464003)	215338	T15 / H	364138	s2.5 / A	364139
465004 (464004)	215338	T15 / H	115180	s2.5 / A	-
465005 (464005)	215338	T15 / H	115505	s3 / B	-
465006 (464006)	215462	T20 / H	315943	s4 / B	-
465007 (464007)	215462	T20 / H	515178	s4 / B	-
465008 (464008)	215462	T20 / H	515178	s4 / B	-
465009 (464009)	215462	T20 / H	515178	s4 / B	-
465010 (464010)	215462	T20 / H	515178	s4 / B	-

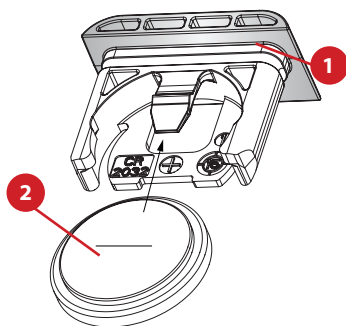

1 Sealing Ring	2 Battery CR2032
Part No.	Part No.
215483	515491

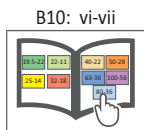
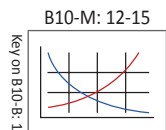

A  
B  
C  
D  
E  
F  
G  
H  
I  
J  
K  
L  
M  
INDEX

# 365 (364) and 465 (464) Product Overview

## Balanced Analog 365 (364) and 465 (464) FINE BORING

### Analog fine boring tools for high-production jobs

Wohlhaupter® 365 (364) and 465 (464) analog balanced boring heads offer precision boring with automatic balancing. Our boring heads are specifically engineered to minimize the residual imbalance produced by insert holder displacement. Wohlhaupter Alu-Line boring heads offer a lightweight aluminum design with a wear-resistant coating that reduces weight on the spindle up to 50% yet remains durable in challenging boring applications. The insert holder can also be rotated for reverse machining jobs.

- 365 (364) diameter range: 0.787" - 1.161" (20.00 mm - 29.50 mm)
- 465 (464) diameter range: 1.142" - 8.071" (29.00 mm - 205.00 mm)
- 465 (464) Alu-Line diameter range: 2.559" - 8.071" (65.00 mm - 205.00 mm)
  - Special coating on Alu-Line for wear-resistant surface
  - Alu-Line body reduces tool weight by 50%, reducing stress on the spindle
- Internal balancing improves tool life and surface finish
- Coolant through
- Vernier diameter adjustment of 0.0001" (0.002 mm)
- Insert holder can be rotated for back boring jobs
- Max cutting speed: 3,281 SFM (1,000 m/min)



**IMPORTANT:** Max spindle speed refers to maximum possible speed for an individual boring head and is not a recommended parameter. Refer to page B10-M: 12 for recommended application-specific parameters. Factory technical assistance is available for your specific applications through our Application Engineering department.  
ext: 7611 | email: [appeng@alliedmachine.com](mailto:appeng@alliedmachine.com)



# WOHLHAUPTER® 465 (464) BALANCED ANALOG BORING HEADS

ANALOG BORING HEAD PART NUMBER CONVERSION			
Diameter Range	Old Part No.	<i>NEW</i> Part No.	
i	0.787 - 0.965	365030	<i>No Change</i>
	0.965 - 1.161	365031	<i>No Change</i>
	1.142 - 1.516	365032	465033
	1.496 - 1.988	365033	465034
	1.969 - 2.579	365034	465035
	2.559 - 3.268	365045	465036
	3.228 - 4.055	365046	465037
	3.937 - 5.118	365047	465038
	4.921 - 6.594	365048	465039
6.398 - 8.071	365049	465040	
m	20.00 - 24.50	364030	<i>No Change</i>
	24.50 - 29.50	364031	<i>No Change</i>
	29.00 - 38.00	364032	464033
	38.00 - 50.00	364033	464034
	50.00 - 65.50	364034	464035
	65.00 - 83.00	364045	464036
	82.00 - 103.00	364046	464037
	100.00 - 130.00	364047	464038
	125.00 - 167.50	364048	464039
162.50 - 205.00	364049	464040	

✓ High-production fine boring

✓ Easy diameter adjustment

✓ Self-balancing

✓ Imperial and metric

FEATURES AN **ENHANCED** CLAMPING MECHANISM FROM OUR TRUSTED LINE OF 565 (564) DIGITAL FINE BORING HEADS

Aluminum bodies with *wear-resistant* coating from 2.559" - 8.071" (65.00 mm - 205.00 mm)



Highly accurate adjustments through *vernier* scale



Equipped with *self-balancing* mechanism

### 365 (364) / 465 (464) Analog Boring Heads

Diameter Range: 0.787" - 2.579" (20.00 mm - 65.50 mm)



365 (364)  
Form 101

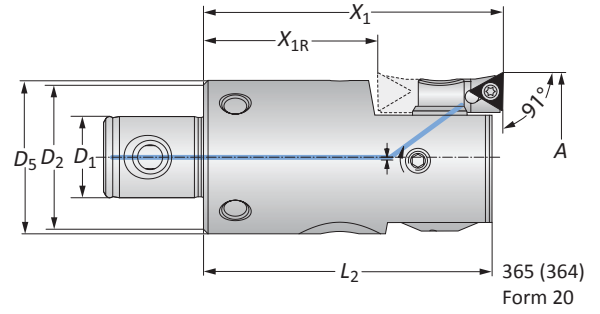
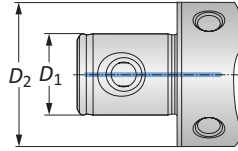

365 (364)  
Form 20



465 (464)  
Form 101

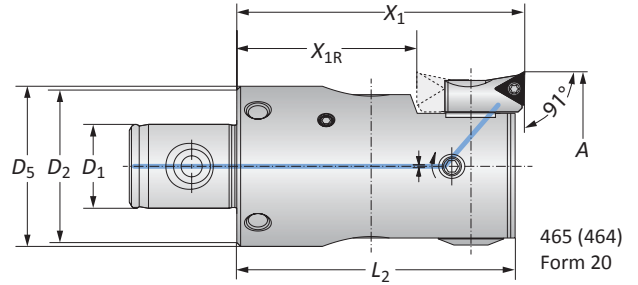

465 (464)  
Form 20

#### 365/465 Boring Heads

MVS Connection	Boring Range	Boring Head					Weight	Insert Form	Part No.	
		$D_2   D_1$	A	$X_1$	$X_{1R}$	$L_2$			$D_5$	Insert Holder
	19 - 11	0.787 - 0.965	1.811	-	1.693	-	0.198 (lbs)	20*	364077	365030
	22 - 11	0.965 - 1.161	1.811	-	1.713	0.906	0.331 (lbs)	20	210059	365031
	22 - 11	0.965 - 1.161	1.811	-	1.713	0.906	0.331 (lbs)	101	210069	365031
	25 - 14	1.142 - 1.516	2.205	-	2.106	1.063	0.441 (lbs)	20	210059	465033
i	25 - 14	1.142 - 1.516	2.205	-	2.106	1.063	0.441 (lbs)	101	210069	465033
	32 - 18	1.496 - 1.988	2.598	1.496	2.450	1.339	0.882 (lbs)	20	264051	465034
	32 - 18	1.496 - 1.988	2.598	1.496	2.450	1.339	0.882 (lbs)	101	264077	465034
	40 - 22	1.969 - 2.579	2.953	1.850	2.854	1.654	1.764 (lbs)	20	210052	465035
	40 - 22	1.969 - 2.579	2.953	1.850	2.854	1.654	1.764 (lbs)	101	210062	465035

\*Not suitable for indexable inserts with a radius of 0.031" (0.80 mm)

NOTE:  $X_{1R}$  = rotated insert holder for reverse machining

NOTE: Insert holders and inserts sold separately

#### 364/464 Boring Heads

MVS Connection	Boring Range	Boring Head					Weight	Insert Form	Part No.	
		$D_2   D_1$	A	$X_1$	$X_{1R}$	$L_2$			$D_5$	Insert Holder
	19 - 11	20.00 - 24.50	46.00	-	43.00	-	0.09 (kg)	20*	364077	364030
	22 - 11	24.50 - 29.50	46.00	-	43.50	23.00	0.15 (kg)	20	210059	364031
	22 - 11	24.50 - 29.50	46.00	-	43.50	23.00	0.15 (kg)	101	210069	364031
	25 - 14	29.00 - 38.00	56.00	-	53.50	27.00	0.20 (kg)	20	210059	464033
m	25 - 14	29.00 - 38.00	56.00	-	53.50	27.00	0.20 (kg)	101	210069	464033
	32 - 18	38.00 - 50.00	66.00	38.00	63.50	34.00	0.40 (kg)	20	264051	464034
	32 - 18	38.00 - 50.00	66.00	38.00	63.50	34.00	0.40 (kg)	101	264077	464034
	40 - 22	50.00 - 65.50	75.00	47.00	72.50	42.00	0.80 (kg)	20	210052	464035
	40 - 22	50.00 - 65.50	75.00	47.00	72.50	42.00	0.80 (kg)	101	210062	464035

\*Not suitable for indexable inserts with a radius of 0.031" (0.80 mm)

NOTE:  $X_{1R}$  = rotated insert holder for reverse machining

NOTE: Insert holders and inserts sold separately

B10-M: 12-15

B10-F

B10: vi-vii

Key on B10-B: 1

i = Imperial (in)  
m = Metric (mm)

**IMPORTANT:** Max spindle speed refers to maximum possible speed for an individual boring head and is not a recommended parameter. Refer to page B10-M: 12 for recommended application-specific parameters. Factory technical assistance is available for your specific applications through our Application Engineering department.  
ext: 7611 | email: [appeng@alliedmachine.com](mailto:appeng@alliedmachine.com)

### 465 (464) Analog Boring Heads

Alu-Line | Diameter Range: 2.559" - 8.071" (65.00 mm - 205.00 mm)



Form 101

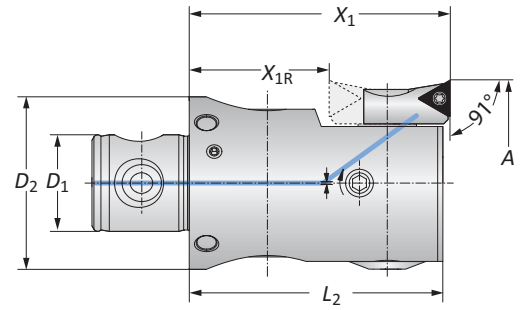
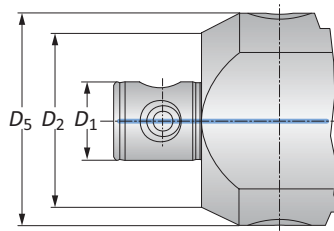

Form 20

#### 465 Alu-Line Boring Heads

MVS Connection	Boring Range	Boring Head				Weight	Insert Form	Part No.	
		$D_2   D_1$	A	$X_1$	$X_{1R}$			$L_2$	$D_5$
50 - 28	2.559 - 3.268	2.953	1.535	2.854	-	1.323 (lbs)	20	210020	465036
50 - 28	2.559 - 3.268	2.953	1.535	2.854	-	1.323 (lbs)	101	210063	465036
50 - 28	2.559 - 3.268	2.953	1.535	2.854	-	1.323 (lbs)	103	210064	465036
63 - 36	3.228 - 4.055	3.543	2.126	3.445	-	2.205 (lbs)	20	210020	465037
63 - 36	3.228 - 4.055	3.543	2.126	3.445	-	2.205 (lbs)	101	210063	465037
63 - 36	3.228 - 4.055	3.543	2.126	3.445	-	2.205 (lbs)	103	210064	465037
80 - 36	3.937 - 5.118	3.543	2.126	3.445	-	3.307 (lbs)	20	210020	465038
80 - 36	3.937 - 5.118	3.543	2.126	3.445	-	3.307 (lbs)	101	210063	465038
80 - 36	3.937 - 5.118	3.543	2.126	3.445	-	3.307 (lbs)	103	210064	465038
80 - 36	4.921 - 6.594	3.543	2.126	3.445	3.937	4.189 (lbs)	20	210020	465039
80 - 36	4.921 - 6.594	3.543	2.126	3.445	3.937	4.189 (lbs)	101	210063	465039
80 - 36	4.921 - 6.594	3.543	2.126	3.445	3.937	4.189 (lbs)	103	210064	465039
80 - 36	6.398 - 8.071	3.543	2.126	3.445	5.315	5.512 (lbs)	20	210020	465040
80 - 36	6.398 - 8.071	3.543	2.126	3.445	5.315	5.512 (lbs)	101	210063	465040
80 - 36	6.398 - 8.071	3.543	2.126	3.445	5.315	5.512 (lbs)	103	210064	465040

NOTE:  $X_{1R}$  = rotated insert holder for reverse machining

NOTE: Insert holders and inserts sold separately

#### 464 Alu-Line Boring Heads

MVS Connection	Boring Range	Boring Head				Weight	Insert Form	Part No.	
		$D_2   D_1$	A	$X_1$	$X_{1R}$			$L_2$	$D_5$
50 - 28	65.00 - 83.00	75.00	39.00	72.50	-	0.60 (kg)	20	210020	464036
50 - 28	65.00 - 83.00	75.00	39.00	72.50	-	0.60 (kg)	101	210063	464036
50 - 28	65.00 - 83.00	75.00	39.00	72.50	-	0.60 (kg)	103	210064	464036
63 - 36	82.00 - 103.00	90.00	54.00	87.50	-	1.00 (kg)	20	210020	464037
63 - 36	82.00 - 103.00	90.00	54.00	87.50	-	1.00 (kg)	101	210063	464037
63 - 36	82.00 - 103.00	90.00	54.00	87.50	-	1.00 (kg)	103	210064	464037
80 - 36	100.00 - 130.00	90.00	54.00	87.50	-	1.50 (kg)	20	210020	464038
80 - 36	100.00 - 130.00	90.00	54.00	87.50	-	1.50 (kg)	101	210063	464038
80 - 36	100.00 - 130.00	90.00	54.00	87.50	-	1.50 (kg)	103	210064	464038
80 - 36	125.00 - 167.50	90.00	54.00	87.50	100.00	1.90 (kg)	20	210020	464039
80 - 36	125.00 - 167.50	90.00	54.00	87.50	100.00	1.90 (kg)	101	210063	464039
80 - 36	125.00 - 167.50	90.00	54.00	87.50	100.00	1.90 (kg)	103	210064	464039
80 - 36	162.50 - 205.00	90.00	54.00	87.50	135.00	2.50 (kg)	20	210020	464040
80 - 36	162.50 - 205.00	90.00	54.00	87.50	135.00	2.50 (kg)	101	210063	464040
80 - 36	162.50 - 205.00	90.00	54.00	87.50	135.00	2.50 (kg)	103	210064	464040

NOTE:  $X_{1R}$  = rotated insert holder for reverse machining

NOTE: Insert holders and inserts sold separately

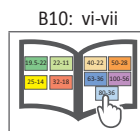
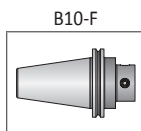
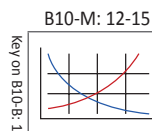

Key on B10-B-1

**i** = Imperial (in)  
**m** = Metric (mm)

**IMPORTANT:** Max spindle speed refers to maximum possible speed for an individual boring head and is not a recommended parameter. Refer to page B10-M: 12 for recommended application-specific parameters. Factory technical assistance is available for your specific applications through our Application Engineering department.  
ext: 7611 | email: [appeng@alliedmachine.com](mailto:appeng@alliedmachine.com)

## Insert Holders for Abrasive Materials

Diameter Range: 2.559" - 8.071" (65.00 mm - 205.00 mm)

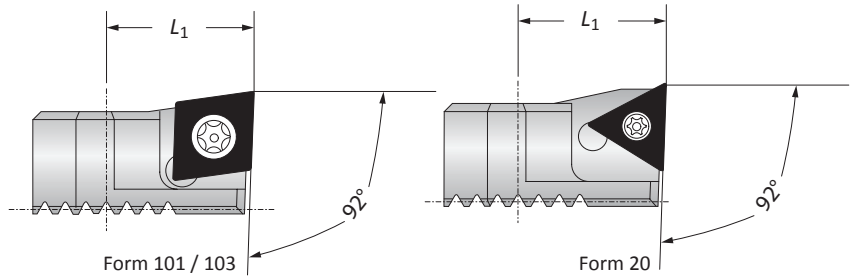

		Insert Holder			
Boring Range		$L_1$	Weight	Insert Form	Part No.
i	2.559 - 8.071	0.709	0.066 (lbs)	20	<b>211061</b>
	2.559 - 8.071	0.709	0.066 (lbs)	101	<b>211063</b>
	2.559 - 8.071	0.709	0.066 (lbs)	103	<b>211065</b>
m	65.00 - 205.00	18.00	0.03 (kg)	20	<b>211061</b>
	65.00 - 205.00	18.00	0.03 (kg)	101	<b>211063</b>
	65.00 - 205.00	18.00	0.03 (kg)	103	<b>211065</b>

**NOTE:** Insert holders used for abrasive materials to protect boring head against chip wash

**NOTE:** When machining grey cast iron, we recommend using insert holders for abrasive materials with CBN inserts for optimized chip removal.

B10-M: 12-15

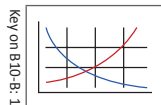

B10-H

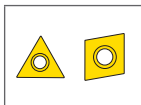

B10: vi-vii

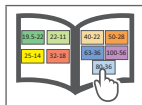

i = Imperial (in)  
m = Metric (mm)

Inserts sold separately

## Accessories

### Screws

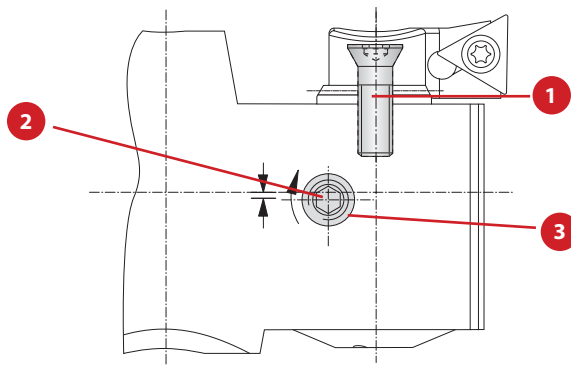

Boring Head	Part No.				
	1 Countersunk Screw	Countersunk Screw Service Key	2 Clamping Screw	Clamping Screw Service Key	3 Ball
365030 (364030)	<b>215323</b>	T15 / H	<b>364260</b>	s2 / A	<b>364270</b>
365031 (364031)	<b>215338</b>	T15 / H	<b>364138</b>	s2.5 / A	<b>364139</b>
465033 (464033)	<b>215338</b>	T15 / H	<b>364138</b>	s2.5 / A	<b>364139</b>
465034 (464034)	<b>215338</b>	T15 / H	<b>115180</b>	s2.5 / A	-
465035 (464035)	<b>215338</b>	T15 / H	<b>115505</b>	s3 / B	-
465036 (464036)	<b>215462</b>	T20 / H	<b>315943</b>	s4 / B	-
465037 (464037)	<b>215462</b>	T20 / H	<b>515178</b>	s4 / B	-
465038 (464038)	<b>215462</b>	T20 / H	<b>515178</b>	s4 / B	-
465039 (464039)	<b>215462</b>	T20 / H	<b>515178</b>	s4 / B	-
465040 (464040)	<b>215462</b>	T20 / H	<b>515178</b>	s4 / B	-

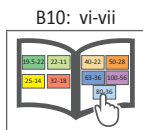
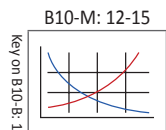

A  
B  
C  
D  
E  
F  
G  
H  
I  
J  
K  
L  
M  
INDEX



# Balanced Digital 565 (564) Product Overview

## Balanced Digital 565 (564) FINE BORING

### Adjustable diameter for precise machining.

Wohlhaupter® Balance Digital 565 (564) boring heads feature automatic balancing with an easy-to-read digital display. For diameter ranges above 2.559" (65.00 mm), 565 (564) boring heads are made of lightweight aluminum. 565 (564) boring heads are specifically engineered to minimize the residual imbalance produced by insert holder displacement. Reverse boring applications can be achieved by rotating the insert holders.

Test the *engineered lightweight* boring head today.

- Diameter range: 1.969" - 8.071" (50.00 mm - 205.00 mm)
- Alu-Line diameter range: 2.559" - 8.071" (65.00 mm - 205.00 mm)
  - Special coating on Alu-Line for wear-resistant surface
  - Alu-Line body reduces tool weight by 50%, reducing stress on the spindle
- Digital readout advantage for diameter adjustments of 0.0001" (0.002 mm)
- Coolant through
- Internal balancing improves tool life and surface finish
- Insert holder can be rotated for back boring jobs
- Max cutting speed: 6,562 SFM (2,000 m/min)
- Max coolant pressure: 580 PSI (40 bar)



**Aluminum Boring Head**  
2.559" - 8.071"  
(65.00 mm - 205.00 mm)



**Steel Boring Head**  
1.969" - 2.579"  
(50.00 mm - 65.50 mm)

**NOTE:** Imperial items pictured

**NOTE:** Adjustment accuracy of 0.0001" or 0.002 mm on diameter

**IMPORTANT:** Max spindle speed refers to maximum possible speed for an individual boring head and is not a recommended parameter. Refer to page B10-M: 12 for recommended application-specific parameters. Factory technical assistance is available for your specific applications through our Application Engineering department.  
ext: 7611 | email: [appeng@alliedmachine.com](mailto:appeng@alliedmachine.com)

# WOHLHAUPTER® 565 BORING HEAD with NOVI<sup>TECH</sup>™

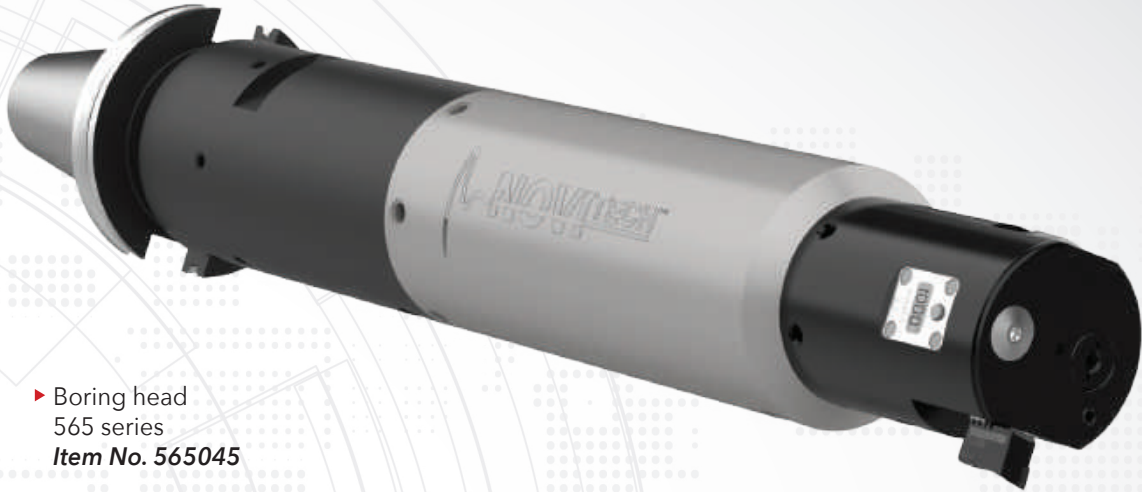

- ▶ Boring head  
565 series  
**Item No. 565045**
- ▶ NOVI<sup>TECH</sup> vibration dampening  
intermediate module  
**Item No. 519005**

**NOTE:** Imperial item pictured

**NOTE:** Adjustment accuracy of 0.0001"  
or 0.002 mm on diameter

*The Wohlhaupter 565 boring head with the  
NOVI<sup>TECH</sup> vibration dampening module provided:*



**Excellent surface finish**



**Eliminated vibration and chatter**

		Measure	565 Boring Head with NOVI <sup>TECH</sup>
<b>Product:</b>	Wohlhaupter 565 Boring Head with NOVI <sup>TECH</sup>	RPM	430 RPM
<b>Objectives:</b>	0.002" concentricity over the length of two bores spaced 14" apart	Speed Rate	352 SFM (107.28 m/min)
<b>Material:</b>	Cast iron	Feed Rate	0.003 IPR (0.08 mm/rev)
<b>Hole Ø:</b>	3.125"	Penetration Rate	1.29 IPM (33 mm/min)
<b>Depth:</b>	7xD	Cycle Time (per hole)	3 min 32 sec
		Hole Finish	155 Ra µin. (3.8 Ra µm)

## Boring Heads

Diameter Range: 1.969" - 2.579" (50.00 mm - 65.50 mm)



NOTE: Imperial item pictured  
NOTE: Adjustment accuracy of 0.0001" or 0.002 mm on diameter

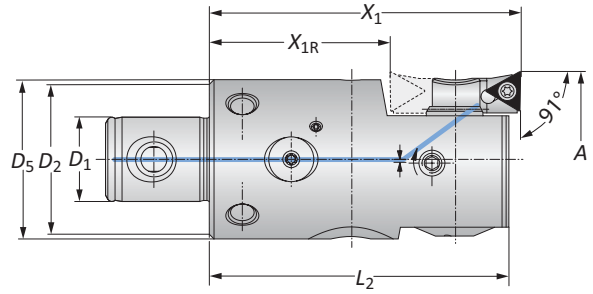

### 565 Digital Boring Heads

Form 101

Form 20

	MVS Connection	Boring Range	Boring Head				Weight	Insert Form	Part No.	
	D <sub>2</sub>   D <sub>1</sub>		A	X <sub>1</sub>	X <sub>1R</sub>	L <sub>2</sub>			D <sub>5</sub>	Insert Holder
<b>i</b>	40 - 22	1.969 - 2.579	2.953	1.850	2.854	1.654	1.764 (lbs)	20	<b>210052</b>	<b>565034</b>
	40 - 22	1.969 - 2.579	2.953	1.850	2.854	1.654	1.764 (lbs)	101	<b>210062</b>	<b>565034</b>

NOTE: X<sub>1R</sub> = rotated insert holder for reverse machining  
NOTE: Insert holders and inserts sold separately

### 564 Digital Boring Heads

	MVS Connection	Boring Range	Boring Head				Weight	Insert Form	Part No.	
	D <sub>2</sub>   D <sub>1</sub>		A	X <sub>1</sub>	X <sub>1R</sub>	L <sub>2</sub>			D <sub>5</sub>	Insert Holder
<b>m</b>	40 - 22	50.00 - 65.50	75.00	47.00	72.50	42.00	0.80 (kg)	20	<b>210052</b>	<b>564034</b>
	40 - 22	50.00 - 65.50	75.00	47.00	72.50	42.00	0.80 (kg)	101	<b>210062</b>	<b>564034</b>

NOTE: X<sub>1R</sub> = rotated insert holder for reverse machining  
NOTE: Insert holders and inserts sold separately

B10-M: 12-15

B10-F

B10: vi-vii

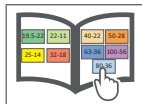
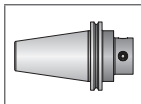
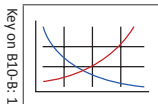

**IMPORTANT:** Max spindle speed refers to maximum possible speed for an individual boring head and is not a recommended parameter. Refer to page B10-M: 12 for recommended application-specific parameters. Factory technical assistance is available for your specific applications through our Application Engineering department.  
ext: 7611 | email: [appeng@alliedmachine.com](mailto:appeng@alliedmachine.com)

**i** = Imperial (in)  
**m** = Metric (mm)

## Boring Heads

Alu-Line | Diameter Range: 2.559" - 8.070" (65.00 mm - 205.00 mm)



**NOTE:** Imperial item pictured  
**NOTE:** Adjustment accuracy of 0.0001" or 0.002 mm on diameter

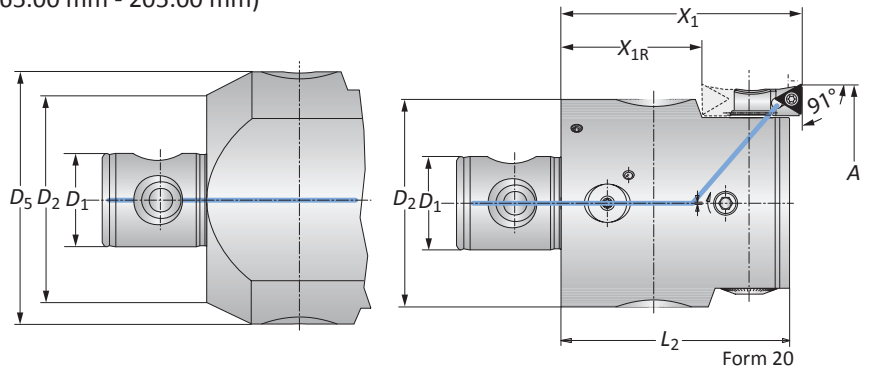

565 Digital Alu-Line Boring Heads Form 101

MVS Connection	Boring Range	Boring Head					Weight	Insert Form	Part No.	
		$D_2   D_1$	A	$X_1$	$X_{1R}$	$L_2$			$D_5$	Insert Holder
50 - 28	2.559 - 3.268	2.953	1.535	2.874	-	1.323 (lbs)	20	210020	565045	
50 - 28	2.559 - 3.268	2.953	1.535	2.874	-	1.323 (lbs)	101	210063	565045	
50 - 28	2.559 - 3.268	2.953	1.535	2.874	-	1.323 (lbs)	103	210064	565045	
63 - 36	3.228 - 4.055	3.543	2.126	3.464	-	2.205 (lbs)	20	210020	565046	
63 - 36	3.228 - 4.055	3.543	2.126	3.464	-	2.205 (lbs)	101	210063	565046	
63 - 36	3.228 - 4.055	3.543	2.126	3.464	-	2.205 (lbs)	103	210064	565046	
80 - 36	3.937 - 5.118	3.543	2.126	3.464	-	3.307 (lbs)	20	210020	565047	
80 - 36	3.937 - 5.118	3.543	2.126	3.464	-	3.307 (lbs)	101	210063	565047	
80 - 36	3.937 - 5.118	3.543	2.126	3.464	-	3.307 (lbs)	103	210064	565047	
80 - 36	4.921 - 6.594	3.543	2.126	3.464	3.397	3.307 (lbs)	20	210020	565048	
80 - 36	4.921 - 6.594	3.543	2.126	3.464	3.937	4.189 (lbs)	101	210063	565048	
80 - 36	4.921 - 6.594	3.543	2.126	3.464	3.937	4.189 (lbs)	103	210064	565048	
80 - 36	6.398 - 8.071	3.543	2.126	3.464	5.315	4.189 (lbs)	20	210020	565049	
80 - 36	6.398 - 8.071	3.543	2.126	3.464	5.315	4.189 (lbs)	101	210063	565049	
80 - 36	6.398 - 8.071	3.543	2.126	3.464	5.315	5.512 (lbs)	103	210064	565049	

**NOTE:**  $X_{1R}$  = rotated insert holder for reverse machining  
**NOTE:** Insert holders and inserts sold separately

564 Digital Alu-Line Boring Heads

MVS Connection	Boring Range	Boring Head					Weight	Insert Form	Part No.	
		$D_2   D_1$	A	$X_1$	$X_{1R}$	$L_2$			$D_5$	Insert Holder
50 - 28	65.00 - 83.00	75.00	39.00	73.00	-	0.60 (kg)	20	210020	564045	
50 - 28	65.00 - 83.00	75.00	39.00	73.00	-	0.60 (kg)	101	210063	564045	
50 - 28	65.00 - 83.00	75.00	39.00	73.00	-	0.60 (kg)	103	210064	564045	
63 - 36	82.00 - 103.00	90.00	54.00	88.00	-	1.00 (kg)	20	210020	564046	
63 - 36	82.00 - 103.00	90.00	54.00	88.00	-	1.00 (kg)	101	210063	564046	
63 - 36	82.00 - 103.00	90.00	54.00	88.00	-	1.00 (kg)	103	210064	564046	
80 - 36	100.00 - 130.00	90.00	54.00	88.00	-	1.50 (kg)	20	210020	564047	
80 - 36	100.00 - 130.00	90.00	54.00	88.00	-	1.50 (kg)	101	210063	564047	
80 - 36	100.00 - 130.00	90.00	54.00	88.00	-	1.50 (kg)	103	210064	564047	
80 - 36	125.00 - 167.50	90.00	54.00	88.00	100.00	1.90 (kg)	20	210020	564048	
80 - 36	125.00 - 167.50	90.00	54.00	88.00	100.00	1.90 (kg)	101	210063	564048	
80 - 36	125.00 - 167.50	90.00	54.00	88.00	100.00	1.90 (kg)	103	210064	564048	
80 - 36	162.50 - 205.00	90.00	54.00	88.00	135.00	2.50 (kg)	20	210020	564049	
80 - 36	162.50 - 205.00	90.00	54.00	88.00	135.00	2.50 (kg)	101	210063	564049	
80 - 36	162.50 - 205.00	90.00	54.00	88.00	135.00	2.50 (kg)	103	210064	564049	

**NOTE:**  $X_{1R}$  = rotated insert holder for reverse machining  
**NOTE:** Insert holders and inserts sold separately

B10-M: 12-15

B10-F

B10: vi-vii

Key on B10-B-1

**i** = Imperial (in)  
**m** = Metric (mm)

**IMPORTANT:** Max spindle speed refers to maximum possible speed for an individual boring head and is not a recommended parameter. Refer to page B10-M: 12 for recommended application-specific parameters. Factory technical assistance is available for your specific applications through our Application Engineering department.  
 ext: 7611 | email: [appeng@alliedmachine.com](mailto:appeng@alliedmachine.com)



## Insert Holder for Abrasive Materials

Diameter Range: 2.559" - 8.071" (65.00 mm - 205.00 mm)

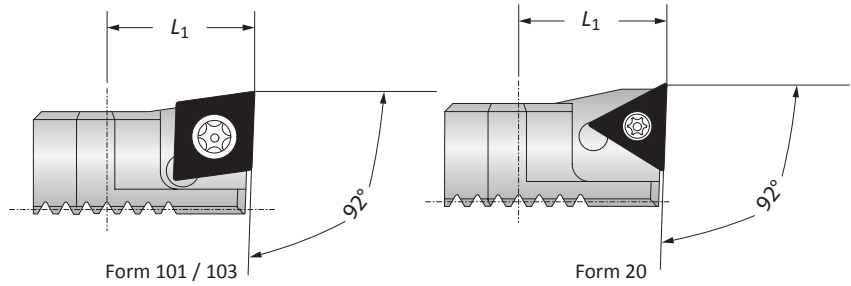

		Insert Holder			
		$L_1$	Weight	Insert Form	Part No.
i	Boring Range				
	2.559 - 8.071	0.709	0.066 (lbs)	20	211061
	2.559 - 8.071	0.709	0.066 (lbs)	101	211063
	2.559 - 8.071	0.709	0.066 (lbs)	103	211065
m	Boring Range				
	65.00 - 205.00	18.00	0.03 (kg)	20	211061
	65.00 - 205.00	18.00	0.03 (kg)	101	211063
	65.00 - 205.00	18.00	0.03 (kg)	103	211065

**NOTE:** Insert holders used for abrasive materials to protect boring head against chip wash

**NOTE:** When machining grey cast iron, we recommend using insert holders for abrasive materials with CBN inserts for optimized chip removal.

B10-M: 12-15

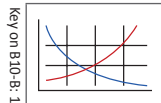

B10-H

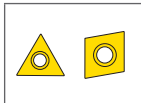

B10: vi-vii

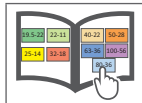

i = Imperial (in)  
m = Metric (mm)

Inserts sold separately



## Accessories

Screws | Battery Cover | Batteries

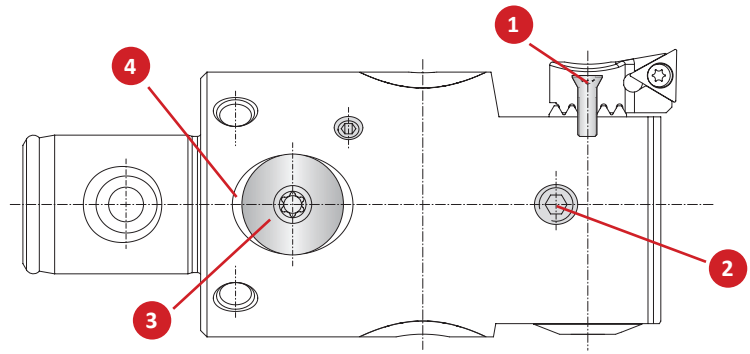

Boring Head	Part No.							
	1 Countersunk Screw	Service Key	2 Clamping Screw	Service Key	3 Battery Cover	Service Key	4 Sealing Ring	Battery*
565034 (564034)	<b>215338</b>	T15 / H	<b>115505</b>	s3 / B	<b>501016</b>	T20 / H	<b>415895</b>	<b>415896</b>
565045 (564045)	<b>215462</b>	T20 / H	<b>315943</b>	s4 / B	<b>501016</b>	T20 / H	<b>415895</b>	<b>415896</b>
565046 (564046)	<b>215462</b>	T20 / H	<b>515178</b>	s4 / B	<b>501016</b>	T20 / H	<b>415895</b>	<b>415896</b>
565047 (564047)	<b>215462</b>	T20 / H	<b>515178</b>	s4 / B	<b>501016</b>	T20 / H	<b>415895</b>	<b>415896</b>
565048 (564048)	<b>215462</b>	T20 / H	<b>515178</b>	s4 / B	<b>501016</b>	T20 / H	<b>415895</b>	<b>415896</b>
565049 (564049)	<b>215462</b>	T20 / H	<b>515178</b>	s4 / B	<b>501016</b>	T20 / H	<b>415895</b>	<b>415896</b>

\*Replace both batteries

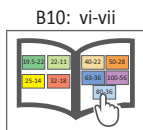
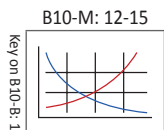

A  
B  
C  
D  
E  
F  
G  
H  
I  
J  
K  
L  
M  
INDEX

# 320 (310) Product Overview

## 320 (310) FINE BORING

### Engineered with wear and tear in mind.

320 (310) Wohlhaupter boring heads are made from steel for  $\varnothing$  0.787" - 4.055" (20.00 mm - 103.00 mm) and coated Alu-Line material for  $\varnothing$  3.937" - 8.071" (100.00 mm - 205.00 mm) boring heads to protect against corrosion and wear. The insert holder can be rotated quickly for reverse machining.

- Diameter range: 0.787" - 8.071" (20.00 mm - 205.00 mm)
- Alu-Line diameter range: 3.937" - 8.071" (100.00 mm - 205.00 mm)
  - Special coating on Alu-Line provides hard, durable surface
  - Alu-Line body reduces tool weight by 50%, reducing stress on the spindle
- Coolant through
- Vernier diameter adjustment of 0.0001" (0.002 mm)
- Max cutting speed: 3,281 SFM (1,000 m/min)



**IMPORTANT:** Max spindle speed refers to maximum possible speed for an individual boring head and is not a recommended parameter. Refer to page B10-M: 12 for recommended application-specific parameters. Factory technical assistance is available for your specific applications through our Application Engineering department.  
ext: 7611 | email: [appeng@alliedmachine.com](mailto:appeng@alliedmachine.com)

# WOHLHAUPTER® 320 BORING HEAD with NOVI<sup>TECH</sup>

## Time is money, so make it count.

If you want to improve your machining processes, cycle time is a key factor to examine. After all, the longer it takes you to produce a part, the fewer parts you can produce in a given time. Our customer was experiencing lengthy cycle times while machining pumps from grey cast iron. The parts required three bored holes, each with a 12" (304.8 mm) depth and a 22" (558.8 mm) reach.

In order to free up machine time, the customer questioned if their process could be more efficient. The main objectives were to decrease the current cycle time and to maintain a 160 Ra finish, which was required to perform the burnishing process that followed.

The previous tooling ran at a slow 0.47 IPM (11.938 mm/min) and a paint-drying 84-minute cycle time to bore the three holes on each part. With our **Wohlhaupter 320 boring head** utilizing the **NOVI<sup>TECH</sup> vibration dampening module**, the customer increased to a more efficient 3.75 IPM (95.25 mm/min) and slashed the cycle time to 10.5 minutes (an 87% decrease). Along with the increased speed, the Wohlhaupter tooling also achieved a 155 Ra finish, accomplishing everything the customer needed.

The Wohlhaupter solution reduced the process cycle time by 74 minutes. Improvements in speed and cycle time can free up machine hours, which means more throughput and higher profit for your company. **Are you losing money on applications with substantially long cycle times?**

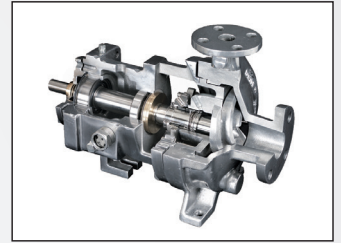

		Measure	Competitor Boring Head	320 Boring Head w/ NOVI <sup>TECH</sup>
<b>Product:</b>	Wohlhaupter 320 Boring Head with NOVI <sup>TECH</sup>	RPM	39	469
<b>Objectives:</b>	(1) Decrease cycle time (2) Maintain 160 Ra hole finish	Speed Rate	56 SFM (17.069 M/min)	675 SFM (205.74 M/min)
<b>Industry:</b>	Oil & gas/petrochemical	Feed Rate	0.012 IPR (0.305 mm/rev)	0.008 IPR (0.203 mm/rev)
<b>Part:</b>	Pump	Penetration Rate	0.47 IPM (11.938 mm/min)	3.75 IPM (92.25 mm/min)
<b>Material:</b>	Grey cast iron	Cycle Time (per hole)	27 min 54 sec	3 min 32 sec
<b>Hole Ø:</b>	5.500" (139.7 mm)	Hole Finish	160 Ra µin. (4 Ra µm)	155 Ra µin. (3.8 Ra µm)
<b>Hole Depth:</b>	12.000" (304.8 mm)			

▶ Boring head  
320 series  
Item No. 320008

▶ NOVI<sup>TECH</sup>  
vibration dampening  
intermediate module  
Item No. 519005

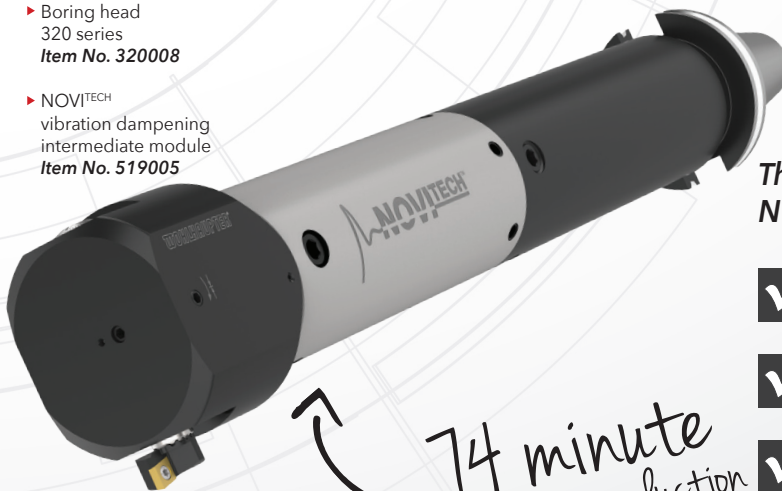

The Wohlhaupter 320 boring head with the NOVI<sup>TECH</sup> vibration dampening module provided:

- ✓ Increased penetration rate
- ✓ Decreased cycle time
- ✓ Excellent finish in deep hole application

## Boring Heads

Diameter Range: 0.787" - 4.055" (20.00 mm - 103.00 mm)

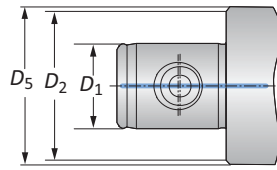

Form 101 / 103

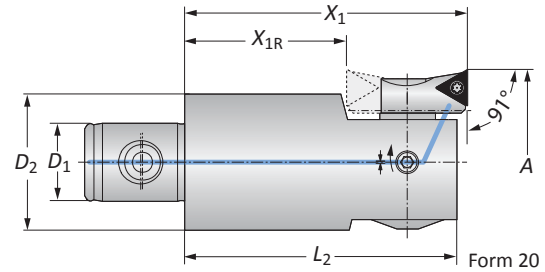

Form 20

### 320 Boring Heads

MVS Connection	Boring Range	Boring Head				Weight	Insert Form	Part No.		
		$D_2   D_1$	A	$X_1$	$X_{1R}$			$L_2$	$D_5$	Insert Holder
	19 - 11	0.787 - 0.965	1.810	-	1.693	-	0.221 (lbs)	20*	364077	320010
	22 - 11	0.965 - 1.161	1.810	-	1.713	0.906	0.331 (lbs)	20	210059	320020
	22 - 11	0.965 - 1.161	1.810	-	1.713	0.906	0.331 (lbs)	101	210069	320020
	25 - 14	1.142 - 1.457	2.200	-	2.106	1.024	0.441 (lbs)	20	210059	320001
	25 - 14	1.142 - 1.457	2.200	-	2.106	1.024	0.441 (lbs)	101	210069	320001
	25 - 14	1.417 - 1.732	2.200	1.100	2.106	1.024	0.441 (lbs)	20	210052	320001
	25 - 14	1.417 - 1.732	2.200	1.100	2.106	1.024	0.441 (lbs)	101	210062	320001
	32 - 18	1.693 - 2.126	2.590	1.490	2.500	-	0.882 (lbs)	20	210052	320003
i	32 - 18	1.693 - 2.126	2.590	1.490	2.500	-	0.882 (lbs)	101	210062	320003
	40 - 22	2.087 - 2.598	2.950	1.530	2.854	-	1.543 (lbs)	20	210020	320004
	40 - 22	2.087 - 2.598	2.950	1.530	2.854	-	1.543 (lbs)	101	210063	320004
	40 - 22	2.087 - 2.598	2.950	1.530	2.854	-	1.543 (lbs)	103	210064	320004
	50 - 28	2.559 - 3.268	2.950	1.530	2.854	-	2.646 (lbs)	20	210020	320005
	50 - 28	2.559 - 3.268	2.950	1.530	2.854	-	2.646 (lbs)	101	210063	320005
	50 - 28	2.559 - 3.268	2.950	1.530	2.854	-	2.646 (lbs)	103	210064	320005
	63 - 36	3.228 - 4.055	3.540	2.120	3.445	-	4.850 (lbs)	20	210020	320006
	63 - 36	3.228 - 4.055	3.540	2.120	3.445	-	4.850 (lbs)	101	210063	320006
	63 - 36	3.228 - 4.055	3.540	2.120	3.445	-	4.850 (lbs)	103	210064	320006

\*Not suitable for indexable inserts with a radius of 0.031" (0.80 mm)

NOTE:  $X_{1R}$  = rotated insert holder for reverse machining

NOTE: Insert holders and inserts sold separately

### 310 Boring Heads

MVS Connection	Boring Range	Boring Head				Weight	Insert Form	Part No.		
		$D_2   D_1$	A	$X_1$	$X_{1R}$			$L_2$	$D_5$	Insert Holder
	19 - 11	20.00 - 24.50	46.00	-	43.00	-	0.10 (kg)	20*	364077	310010
	22 - 11	24.50 - 29.50	46.00	-	43.50	23.00	0.15 (kg)	20	210059	310020
	22 - 11	24.50 - 29.50	46.00	-	43.50	23.00	0.15 (kg)	101	210069	310020
	25 - 14	29.00 - 37.00	56.00	-	53.50	26.00	0.20 (kg)	20	210059	310001
	25 - 14	29.00 - 37.00	56.00	-	53.50	26.00	0.20 (kg)	101	210069	310001
	25 - 14	36.00 - 44.00	56.00	28.00	53.50	26.00	0.20 (kg)	20	210052	310001
	25 - 14	36.00 - 44.00	56.00	28.00	53.50	26.00	0.20 (kg)	101	210062	310001
	32 - 18	43.00 - 54.00	66.00	38.00	63.50	-	0.40 (kg)	20	210052	310003
m	32 - 18	43.00 - 54.00	66.00	38.00	63.50	-	0.40 (kg)	101	210062	310003
	40 - 22	53.00 - 66.00	75.00	39.00	72.50	-	0.70 (kg)	20	210020	310004
	40 - 22	53.00 - 66.00	75.00	39.00	72.50	-	0.70 (kg)	101	210063	310004
	40 - 22	53.00 - 66.00	75.00	39.00	72.50	-	0.70 (kg)	103	210064	310004
	50 - 28	65.00 - 83.00	75.00	39.00	72.50	-	1.20 (kg)	20	210020	310005
	50 - 28	65.00 - 83.00	75.00	39.00	72.50	-	1.20 (kg)	101	210063	310005
	50 - 28	65.00 - 83.00	75.00	39.00	72.50	-	1.20 (kg)	103	210064	310005
	63 - 36	82.00 - 103.00	90.00	54.00	87.50	-	2.20 (kg)	20	210020	310006
	63 - 36	82.00 - 103.00	90.00	54.00	87.50	-	2.20 (kg)	101	210063	310006
	63 - 36	82.00 - 103.00	90.00	54.00	87.50	-	2.20 (kg)	103	210064	310006

\*Not suitable for indexable inserts with a radius of 0.031" (0.80 mm)

NOTE:  $X_{1R}$  = rotated insert holder for reverse machining

NOTE: Insert holders and inserts sold separately

i = Imperial (in)

m = Metric (mm)

**IMPORTANT:** Max spindle speed refers to maximum possible speed for an individual boring head and is not a recommended parameter. Refer to page B10-M: 12 for recommended application-specific parameters. Factory technical assistance is available for your specific applications through our Application Engineering department.

ext: 7611 | email: [appeng@alliedmachine.com](mailto:appeng@alliedmachine.com)



## Boring Heads

Alu-Line | Diameter Range: 3.937" - 8.071" (100.00 mm - 205.00 mm)



Form 101 / 103

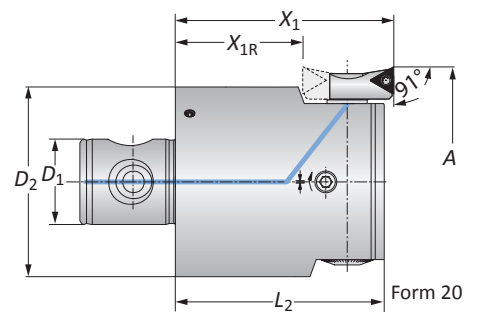
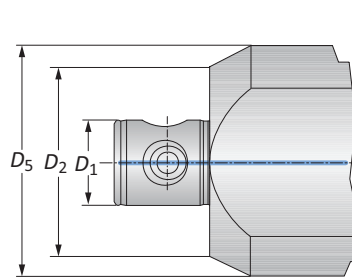

Form 20

### Alu-Line 320 Boring Heads

	MVS Connection	Boring Range	Boring Head				Weight	Insert Form	Part No.	
			$D_2$   $D_1$	A	$X_1$	$X_{1R}$			$L_2$	$D_5$
i	80 - 36	3.937 - 5.118	3.543	2.126	3.445	-	3.086 (lbs)	20	210020	320007
	80 - 36	3.937 - 5.118	3.543	2.126	3.445	-	3.086 (lbs)	101	210063	320007
	80 - 36	3.937 - 5.118	3.543	2.126	3.445	-	3.086 (lbs)	103	210064	320007
	80 - 36	4.921 - 6.594	3.543	2.126	3.445	3.937	3.968 (lbs)	20	210020	320008
	80 - 36	4.921 - 6.594	3.543	2.126	3.445	3.937	3.968 (lbs)	101	210063	320008
	80 - 36	4.921 - 6.594	3.543	2.126	3.445	3.937	3.968 (lbs)	103	210064	320008
	80 - 36	6.397 - 8.071	3.543	2.126	3.445	5.315	5.291 (lbs)	20	210020	320009
	80 - 36	6.397 - 8.071	3.543	2.126	3.445	5.315	5.291 (lbs)	101	210063	320009
	80 - 36	6.397 - 8.071	3.543	2.126	3.445	5.315	5.291 (lbs)	103	210064	320009

NOTE:  $X_{1R}$  = rotated insert holder for reverse machining

NOTE: Insert holders and inserts sold separately

### Alu-Line 310 Boring Heads

	MVS Connection	Boring Range	Boring Head				Weight	Insert Form	Part No.	
			$D_2$   $D_1$	A	$X_1$	$X_{1R}$			$L_2$	$D_5$
m	80 - 36	100.00 - 130.00	90.00	54.00	87.50	-	1.40 (kg)	20	210020	310007
	80 - 36	100.00 - 130.00	90.00	54.00	87.50	-	1.40 (kg)	101	210063	310007
	80 - 36	100.00 - 130.00	90.00	54.00	87.50	-	1.40 (kg)	103	210064	310007
	80 - 36	125.00 - 167.50	90.00	54.00	87.50	100.00	1.80 (kg)	20	210020	310008
	80 - 36	125.00 - 167.50	90.00	54.00	87.50	100.00	1.80 (kg)	101	210063	310008
	80 - 36	125.00 - 167.50	90.00	54.00	87.50	100.00	1.80 (kg)	103	210064	310008
	80 - 36	162.50 - 205.00	90.00	54.00	87.50	135.00	2.40 (kg)	20	210020	310009
	80 - 36	162.50 - 205.00	90.00	54.00	87.50	135.00	2.40 (kg)	101	210063	310009
	80 - 36	162.50 - 205.00	90.00	54.00	87.50	135.00	2.40 (kg)	103	210064	310009

NOTE:  $X_{1R}$  = rotated insert holder for reverse machining

NOTE: Insert holders and inserts sold separately

B10-M: 12-15

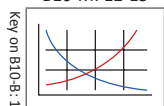

B10-F

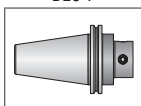

B10: vi-vii



i = Imperial (in)

m = Metric (mm)

**IMPORTANT:** Max spindle speed refers to maximum possible speed for an individual boring head and is not a recommended parameter. Refer to page B10-M: 12 for recommended application-specific parameters. Factory technical assistance is available for your specific applications through our Application Engineering department.

ext: 7611 | email: [appeng@alliedmachine.com](mailto:appeng@alliedmachine.com)

## Insert Holders for Abrasive Materials | Serrated Shims

Diameter Range: 2.087" - 8.071" (53.00 mm - 205.00 mm)

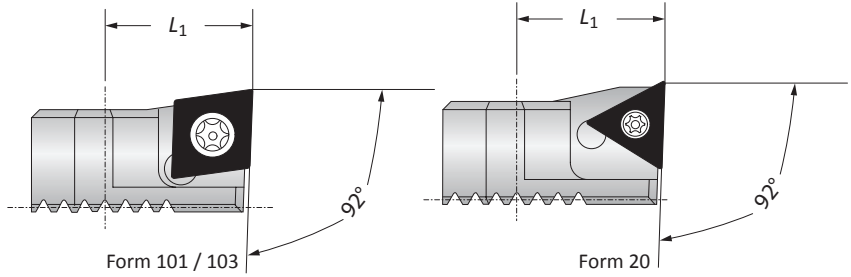

### Insert Holders

Boring Range		Insert Holder	Weight	Insert Form	Part No.
		$L_1$			
i	2.087 - 8.071	0.709	0.066 (lbs)	20	211061
	2.087 - 8.071	0.709	0.066 (lbs)	101	211063
	2.087 - 8.071	0.709	0.066 (lbs)	103	211065
m	53.00 - 205.00	18.00	0.03 (kg)	20	211061
	53.00 - 205.00	18.00	0.03 (kg)	101	211063
	53.00 - 205.00	18.00	0.03 (kg)	103	211065

**NOTE:** Insert holders used for abrasive materials to protect boring head against chip wash

**NOTE:** When machining grey cast iron, we recommend using insert holders for abrasive materials with CBN inserts for optimized chip removal.

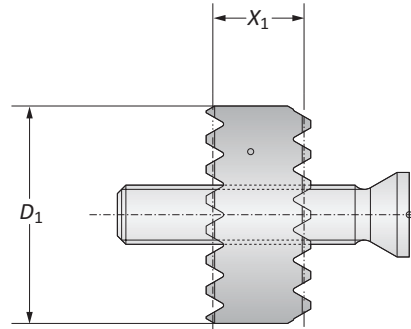

### Serrated Shims

	Boring Range	Additional Boring Range	Serrated Shim		Weight	Part No.	
			$X_1$	$D_1$		Serrated Shim & Screw	Replacement Screw
i	1.141 - 2.126	0.315	0.157	0.472	0.022 (lbs)	310070	415360
	1.141 - 2.126	0.472	0.236	0.472	0.022 (lbs)	310071	415342
	2.087 - 8.071	0.394	0.196	0.708	0.022 (lbs)	310074	515595
	2.087 - 8.071	0.590	0.295	0.708	0.022 (lbs)	310075	515596
m	29.00 - 54.00	8.00	4.00	12.00	0.01 (kg)	310070	415360
	29.00 - 54.00	12.00	6.00	12.00	0.01 (kg)	310071	415342
	53.00 - 205.00	10.00	5.00	18.00	0.01 (kg)	310074	515595
	53.00 - 205.00	15.00	7.50	18.00	0.01 (kg)	310075	515596

B10-M: 12-15      B10-H      B10: vi-vii

Key on B10-B: 1

i = Imperial (in)  
m = Metric (mm)  
Inserts sold separately



## Accessories

### Screws

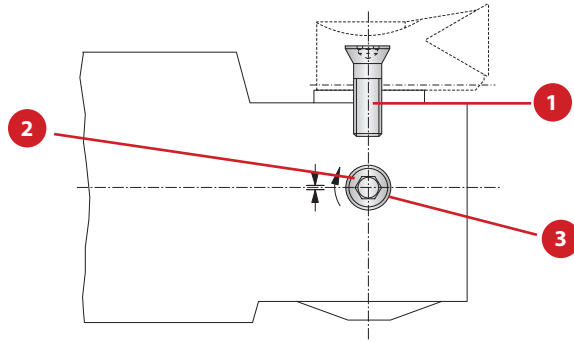

Boring Head	1 Countersunk Screw		2 Clamping Screw		3 Ball
	Part No.	Service Key	Part No.	Service Key	Part No.
320010 (310010)	215323	T15 / H	364260	s2.0 / A	364270
320020 (310020)	215338	T15 / H	364138	s2.5 / A	364139
320001 (310001)	215338	T15 / H	115136	s2.5 / A	-
320003 (310003)	215338	T15 / H	115180	s2.5 / A	-
320004 (310004)	215462	T20 / H	115249	s4 / B	-
320005 (310005)	215462	T20 / H	115185	s4 / B	-
320006 (310006)	215462	T20 / H	315279	s4 / B	-
320007 (310007)	215462	T20 / H	115186	s4 / B	-
320008 (310008)	215462	T20 / H	115186	s4 / B	-
320009 (310009)	215462	T20 / H	115186	s4 / B	-

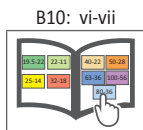
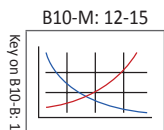

A  
B  
C  
D  
E  
F  
G  
H  
I  
J  
K  
L  
M  
INDEX

# 538 (537) Product Overview



## 538 (537) Cassettes FINE BORING

### Engineered for easy precision.

538 (537) fine boring cassettes offer high accuracy and are available in an easy-to-use digital or analog version. The digital version features a docking port to attach the 3E<sup>TECH</sup> digital readout module for  $\mu$ -accurate diameter adjustments while the analog cassettes provide highly accurate adjustments through the vernier scale. 538 (537) cassettes are made of hardened steel and can be used on serrated tool bodies and slides from 3.937" - 128.150" (100.00 mm - 3255.00 mm). The insert holder can be rotated easily for reverse machining applications.

Experience **digital precision boring** for yourself.

- Diameter range: 3.937" - 8.071" (100.00 mm - 205.00 mm)
- Cassette can be used on large diameter serrated slides (pg. B10-G: 8): 7.874" - 128.150" (200.00 mm - 3255.00 mm)
- Coolant through
- 3E<sup>TECH</sup> module provides a simple digital readout
- Analog version with a vernier scale
- Max cutting speed: 2,953 SFM (900 m/min)



NOTE: Imperial items pictured

NOTE: Adjustment accuracy of 0.0001" or 0.002 mm on diameter

**IMPORTANT:** Max spindle speed refers to maximum possible speed for an individual boring head and is not a recommended parameter. Refer to page B10-M: 12 for recommended application-specific parameters. Factory technical assistance is available for your specific applications through our Application Engineering department.  
ext: 7611 | email: [appeng@alliedmachine.com](mailto:appeng@alliedmachine.com)

# 538 (537) BORING CASSETTES

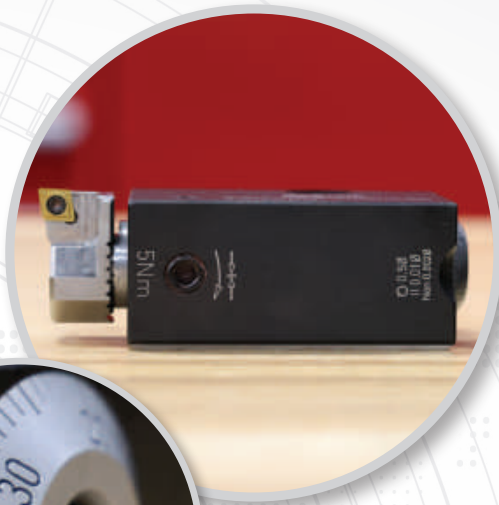

**NEW** vernier scale  
on both analog  
and digital cassettes

**NEW** digital 538 (537)  
cassettes with 3E<sup>TECH</sup>  
docking port

- ✓ Convenient tool handling
- ✓ Large range of applications
- ✓ Hardened steel bodies

## 538 (537) Analog Cassettes

Diameter Range: 3.937" - 8.071" (100.00 mm - 205.00 mm)



Form 101 / 103

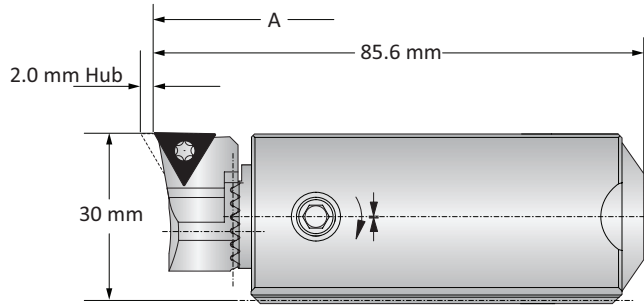

Form 20

### Analog 538 (537) Cassettes

	Boring Range	Weight	Insert Form	Part No.		
				Insert Holder	Clamping Piece	Cassette*
i	3.937 - 8.071	1.323 (lbs)	20	210020	137026	538051
	3.937 - 8.071	1.323 (lbs)	101	210063	137026	538051
	3.937 - 8.071	1.323 (lbs)	103	210064	137026	538051
m	100.00 - 205.00	0.60 (kg)	20	210020	137026	537051
	100.00 - 205.00	0.60 (kg)	101	210063	137026	537051
	100.00 - 205.00	0.60 (kg)	103	210064	137026	537051

\*Required serrated tool body sold separately

NOTE: Cassette and insert holder can be used on large diameter serrated slides (B10-G: 8)

NOTE: Insert holders, inserts, and clamping pieces **sold separately**

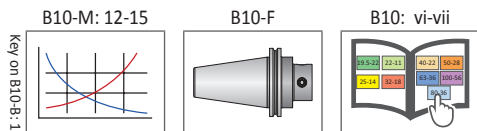

i = Imperial (in)  
m = Metric (mm)

**IMPORTANT:** Max spindle speed refers to maximum possible speed for an individual boring head and is not a recommended parameter. Refer to page B10-M: 12 for recommended application-specific parameters. Factory technical assistance is available for your specific applications through our Application Engineering department.  
ext: 7611 | email: [appeng@alliedmachine.com](mailto:appeng@alliedmachine.com)

### 538 (537) Cassettes with 3E<sup>TECH</sup>

Diameter Range: 3.937" - 8.071" (100.00 mm - 205.00 mm)



Form 101 / 103

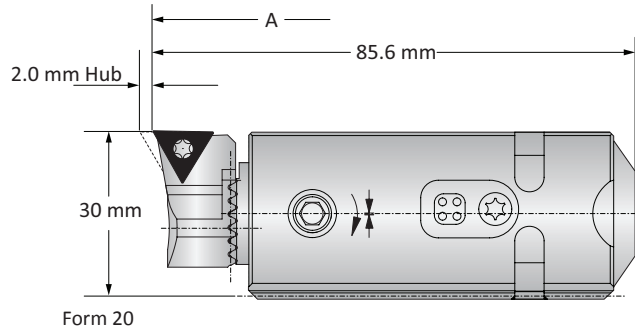

#### Digital 538 (537) Cassettes

	Boring Range	Weight	Insert Form	Insert Holder	Part No.	
					Clamping Piece	Cassette*
<b>i</b>	3.937 - 8.071	1.323 (lbs)	20	<b>210020</b>	<b>137026</b>	<b>538052</b>
	3.937 - 8.071	1.323 (lbs)	101	<b>210063</b>	<b>137026</b>	<b>538052</b>
	3.937 - 8.071	1.323 (lbs)	103	<b>210064</b>	<b>137026</b>	<b>538052</b>
<b>m</b>	100.00 - 205.00	0.60 (kg)	20	<b>210020</b>	<b>137026</b>	<b>537052</b>
	100.00 - 205.00	0.60 (kg)	101	<b>210063</b>	<b>137026</b>	<b>537052</b>
	100.00 - 205.00	0.60 (kg)	103	<b>210064</b>	<b>137026</b>	<b>537052</b>

\*Required serrated tool body sold separately

**NOTE:** Cassette and insert holder can be used on large diameter serrated slides (B10-G: 8)

**NOTE:** 3E<sup>TECH</sup> digital readout module, insert holders, inserts, and clamping pieces **sold separately**



#### 3E<sup>TECH</sup> Digital Readout Module

	Part No.
<b>i</b>	<b>563010</b>
<b>m</b>	<b>536010</b>

**NOTE:** WEEE-Reg.-Nr. DE 15820388

**NOTE:** 3E<sup>TECH</sup> sold separately

**NOTE:** Imperial item pictured  
**NOTE:** Adjustment accuracy of 0.0001" or 0.002 mm on diameter

B10-M: 12-15

Key on B10-B: 1

B10-F

B10: vi-vii

**i** = Imperial (in)  
**m** = Metric (mm)

**IMPORTANT:** Max spindle speed refers to maximum possible speed for an individual boring head and is not a recommended parameter. Refer to page B10-M: 12 for recommended application-specific parameters. Factory technical assistance is available for your specific applications through our Application Engineering department.  
 ext: 7611 | email: [appeng@alliedmachine.com](mailto:appeng@alliedmachine.com)

A  
B  
C  
D  
E  
F  
G  
H  
I  
J  
K  
L  
M  
INDEX



## Serrated Tool Bodies | Insert Holders for Abrasive Materials

Diameter Range: 3.937" - 8.071" (100.00 mm - 205.00 mm)

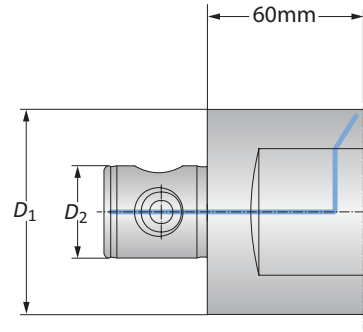

### Serrated Tool Bodies

MVS Connection		Serrated Tool Body	
	$D_2   D_1$	Boring Range	Part No.
i	80 - 36	3.937 - 6.102	148007
	80 - 36	5.906 - 8.071	148009
m	80 - 36	100.00 - 155.00	148007
	80 - 36	150.00 - 205.00	148009

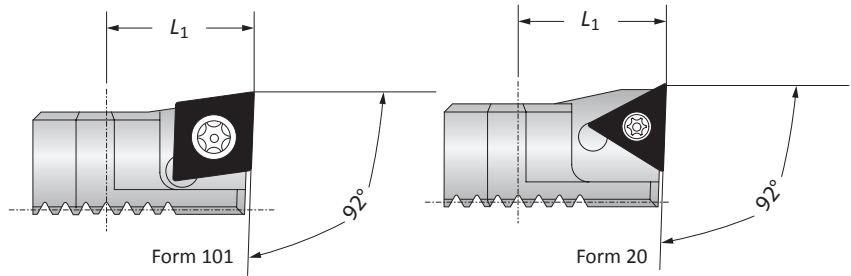

### Insert Holders for Abrasive Materials

Insert Holder		Insert Holder		Insert Holder	
Boring Range	$L_1$	Weight	Insert Form	Part No.	
i	3.937 - 8.071	0.709	0.066 (lbs)	20	211061
	3.937 - 8.071	0.709	0.066 (lbs)	101	211063
	3.937 - 8.071	0.709	0.066 (lbs)	103	211065
m	100.00 - 205.00	18.00	0.03 (kg)	20	211061
	100.00 - 205.00	18.00	0.03 (kg)	101	211063
	100.00 - 205.00	18.00	0.03 (kg)	103	211065

**NOTE:** Insert holders used for abrasive materials to protect boring head against chip wash

**NOTE:** When machining grey cast iron, we recommend using insert holders for abrasive materials with CBN inserts for optimized chip removal.

B10-M: 12-15

Key on B10-B: 1

B10-H

B10: vi-vii

i = Imperial (in)  
m = Metric (mm)



538 (537) Accessories | 3E<sup>TECH</sup> Accessories | Clamping Pieces

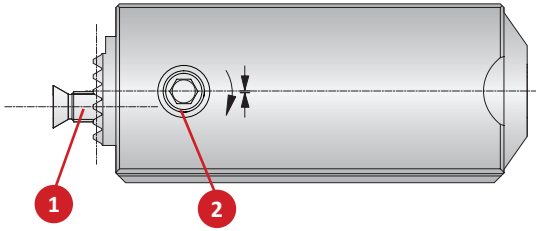

538 (537) Analog Cassette

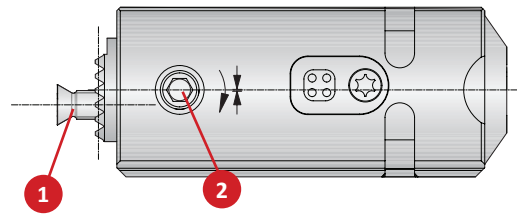

538 (537) Cassette

538 (537) Accessories

Cassette Part No.	1 Countersunk Screw		2 Clamping Screw	
	Part No.	Service Key	Part No.	Service Key
i 538051	215462	T20 / H	115249	s4 / F
	538052	215462	315789	s4 / F
m 537051	215462	T20 / H	115249	s4 / F
	537052	215462	315789	s4 / F

3E<sup>TECH</sup> Accessories

1 Sealing Ring	2 Battery CR2032
Part No.	Part No.
215483	515491

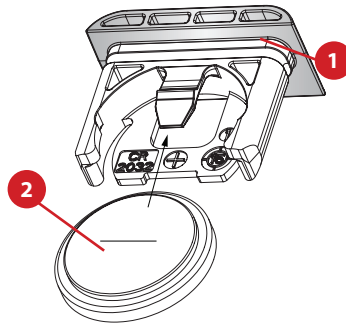

538 (537) Clamping Pieces

Slide Type	Complete Part No.	Service Key	Replacement Components		
			1 Cap Screw	2 Clamping Nut	3 Disk Spring
Serrated Tool Bodies	137026	115578 s6 / B	215101	140118	337105
Basic and Eco Slides	137027		215102	215105	337105
Flex Slides	137019		415900	215105	337105

NOTE: Clamping pieces sold separately

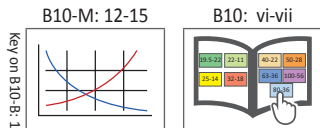
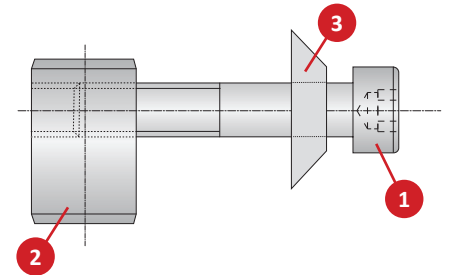

i = Imperial (in)  
m = Metric (mm)  
Inserts sold separately

A  
B  
C  
D  
E  
F  
G  
H  
I  
J  
K  
L  
M  
INDEX

# Guaranteed Test / Demo Application Form

Distributor PO # \_\_\_\_\_

The following must be filled out completely before your test will be considered

**IMPORTANT:** For processing, send Purchase Order to your Allied Field Sales Engineer (FSE). Please clearly mark the paperwork as "Test Order."

## Distributor Information

Company Name: \_\_\_\_\_  
 Contact: \_\_\_\_\_  
 Account Number: \_\_\_\_\_  
 Phone: \_\_\_\_\_  
 Email: \_\_\_\_\_

## End User Information

Company Name: \_\_\_\_\_  
 Contact: \_\_\_\_\_  
 Industry: \_\_\_\_\_  
 Phone: \_\_\_\_\_  
 Email: \_\_\_\_\_

**Current Process** List all tooling, coatings, substrates, speeds and feeds, tool life, and any problems you are experiencing

\_\_\_\_\_

\_\_\_\_\_

**Test Objective** List what would make this a successful test (i.e. penetration rate, finish, tool life, hole size, etc.)

\_\_\_\_\_

\_\_\_\_\_

## Application Information

Hole Diameter: _____ in/mm	Tolerance: _____	Material: _____ (4150 / A36 / Cast Iron / etc.)
Preexisting Diameter: _____ in/mm	Depth of Cut: _____ in/mm	Hardness: _____ (BHN / Rc)
Required Finish: _____ RMS	State: _____	(Casting / Hot rolled / Forging)

## Machine Information

Machine Type: _____ (Lathe / Screw machine / Machine center / etc.)	Builder: _____ (Haas, Mori Seiki, etc.)	Model #: _____
Shank Required: _____ (CAT50 / Morse taper, etc.)		Power: _____ HP/KW
Rigidity: _____	Orientation: _____	Tool Rotating: _____
<input type="checkbox"/> Excellent	<input type="checkbox"/> Vertical	<input type="checkbox"/> Yes
<input type="checkbox"/> Good	<input type="checkbox"/> Horizontal	<input type="checkbox"/> No
<input type="checkbox"/> Poor		Thrust: _____ lbs/N

## Coolant Information

Coolant Delivery: _____ (Through tool / Flood)	Coolant Pressure: _____ PSI / bar
Coolant Type: _____ (Air mist, oil, synthetic, water soluble, etc.)	Coolant Volume: _____ GPM / LPM

## Requested Tooling

QTY	Item Number	QTY	Item Number



**Allied Machine & Engineering**  
 120 Deeds Drive  
 Dover, OH 44622

Telephone: (330) 343-4283  
 Toll Free USA & Canada: (800) 321-5537  
 Fax: (330) 602-3400  
 Email: info@alliedmachine.com

## Warranty Information



Allied Machine & Engineering ("Allied Machine") warrants to original equipment manufacturers, distributors, industrial and commercial users of its products for one year from the original date of sale that each new product manufactured or supplied by Allied Machine shall be free from defects in material and workmanship.

Allied Machine's sole and exclusive obligation under this warranty is limited to, at its option, without additional charge, replacing or repairing this product or issuing a credit. For this warranty to be applied, the product must be returned freight prepaid to the plant designated by an Allied Machine representative and which, upon inspection, is determined by Allied Machine to be defective in material and workmanship.

Complete information as to operating conditions, machine, setup, and the application of cutting fluid should accompany any product returned for inspection. This warranty shall not apply to any Allied Machine products which have been subjected to misuse, abuse, improper operating conditions, improper machine setup or improper application of cutting fluid or which have been repaired or altered if such repair or alteration, in the judgement of Allied Machine, would adversely affect the performance of the product.

THIS WARRANTY IS IN LIEU OF ALL OTHER WARRANTIES, EXPRESS OR IMPLIED, INCLUDING ANY IMPLIED WARRANTY OF MERCHANTABILITY OR FITNESS FOR A PARTICULAR PURPOSE. Allied Machine shall have no liability or responsibility for any claim, whether in contract, tort or otherwise, for any loss or damage arising out of, connected with, or resulting from the manufacture, sale, delivery or use of any product sold hereunder, in excess of the cost of replacement or repair as provided herein.

Allied Machine shall not be liable in contract or in tort (including, without limitation, negligence, strict liability or otherwise) for economic losses of any kind or for any special, incidental, indirect, consequential, punitive or exemplary damages arising in any way out of the performance of, or failure to perform this agreement.

ALL PRICES, DELIVERIES, DESIGNS, AND MATERIALS ARE SUBJECT TO CHANGE WITHOUT NOTICE.



Allied Machine & Engineering  
is registered to  
ISO 9001:2015 by DQS



Wohlhaupter GmbH  
is registered to  
ISO 9001:2015 by QA TECHNICH

## Deutschland | Österreich | Schweiz

**Wohlhaupter GmbH**  
Maybachstraße 4  
72636 Frickenhausen  
Germany

**Telefon:**  
+49 (0) 7022 408-0  
**Email:**  
info@wohlhaupter.de  
**Web:**  
www.wohlhaupter.com

## Europa

**Allied Machine & Engineering Co. (Europe) Ltd.**  
93 Vantage Point  
Pensnett Estate  
Kingswinford  
West Midlands  
DY6 7FR England

**Telefon:**  
+44 (0) 1384 400900  
**Email:**  
enquiries.eu@alliedmachine.com  
**Web:**  
www.alliedmachine.com

## Vereinigte Staaten

**Allied Machine & Engineering**  
120 Deeds Drive  
Dover OH 44622  
United States

**Telefon:**  
+1 330 343 4283  
**Fax:**  
+1 330 602 3400

**Allied Machine & Engineering**  
485 W Third Street  
Dover OH 44622  
United States

**Telefon:**  
+1 330 343 4283  
**Fax:**  
+1 330 364 7666  
(Engineering Dept.)

## Asien

**Wohlhaupter India Pvt. Ltd.**  
B-23, 2nd Floor  
B Block Community Centre  
Janakpuri, New Delhi - 110058  
India

**Telefon:**  
+91 11 41827044



台北: 02-27030193  
台中: 04-24636890

Website: [www.gcarbide.com](http://www.gcarbide.com)

[www.wohlhaupter.com](http://www.wohlhaupter.com)

90200 06.2018  
Printed in Germany - Technische Änderungen vorbehalten

Holemaking Solutions for Today's Manufacturing