

bilz

Micro-Spannzangenhalter
Micro collet holder

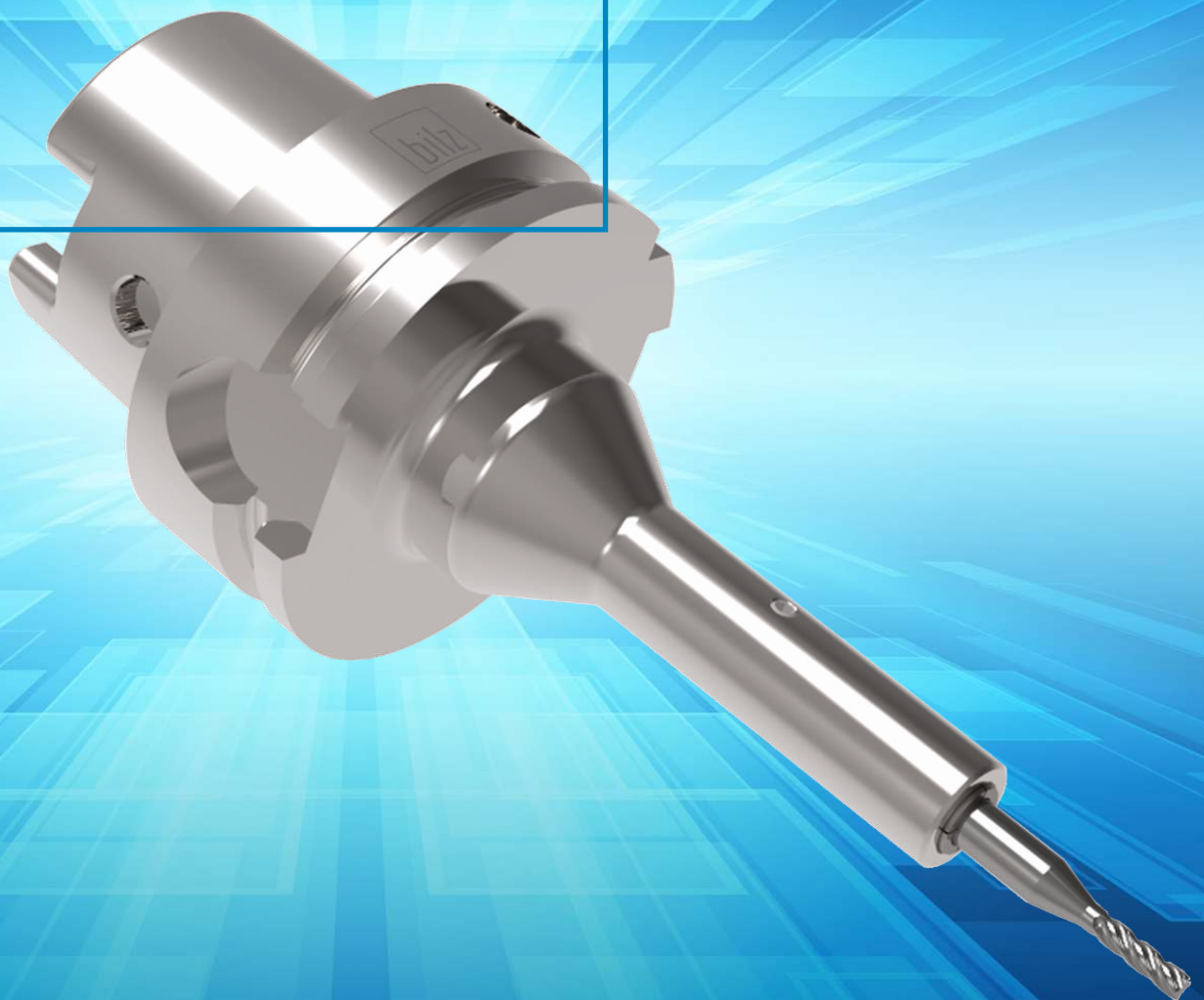

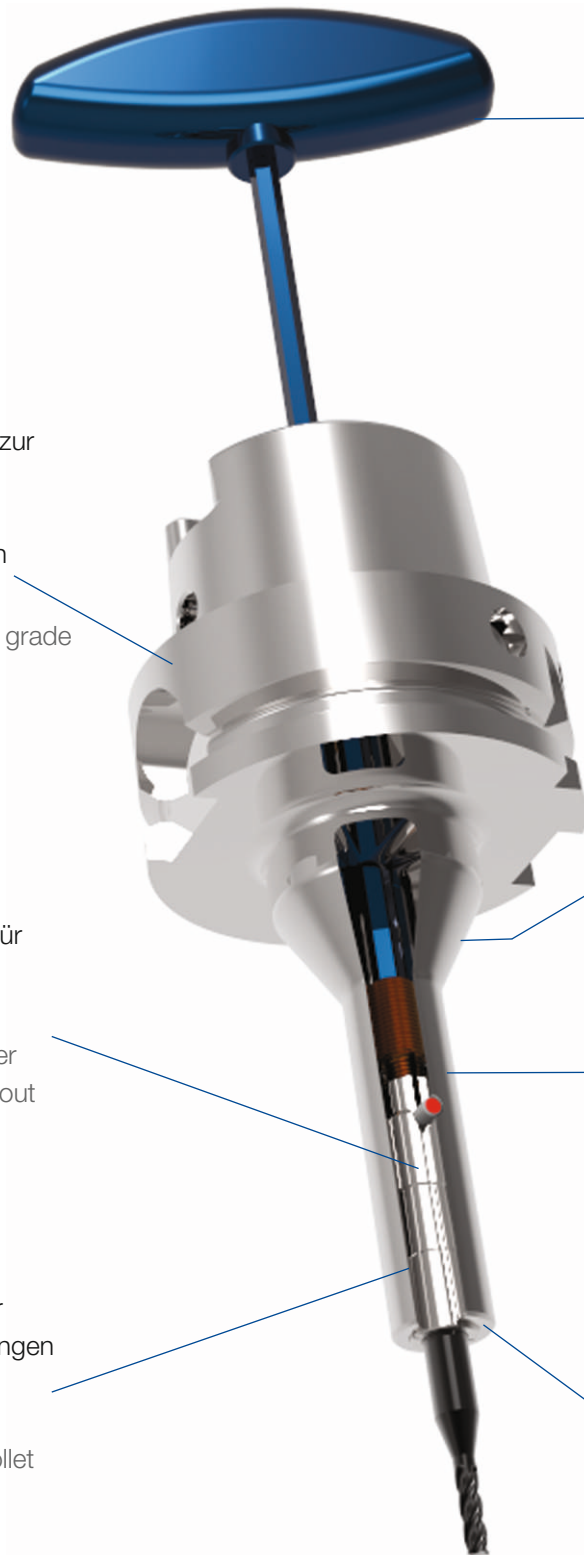

Spezienschlüssel zum Anziehen der Spannzange
Special wrench for appropriate collet tightening

Symmetrisches Design zur Erzielung einer hohen Auswuchtgüte G2,5 bei 35.000 U / min
Symmetric design – to achieve high balancing grade G2.5 @ 35,000 rpm

Hohe Steifigkeit und große Stabilität
Strong rigidity and high stability

Präzisionsspannzange für längere Haltelängen mit 5µm Rundlauf bei 3D
Precision collet for higher holding length with run-out of 5µm @ 3D

Schlankes Design für tiefe Kavitäten und Bearbeitungen mit hoher Drehzahl (> 10.000 U / min)
Slim design for easy reach and high speed machining (>10,000 RPM)

Stabile Spannzange mit spezieller Aufnahme für längere Spannzangenlängen (15/30 mm)
Strong collet to holder fitment due to longer collet length (15/30mm)

Durch das nutfreie Design werden Vibrationen und Geräusche wirksam reduziert
The nut-less design effectively reduces vibration and noise

Schlankes Design für tiefe Kavitäten
Slim design for easy reach

Steilkegel mit Plananlage
Dual Face Contact

Hohe Rundlaufgenauigkeit
High run-out accuracy

Oberflächengüte
Surface finish

* Micro collet extensions are available, please refer in accessories page for more information

Micro-Spannzangenhalter (BT)

Micro collet holder (BT)

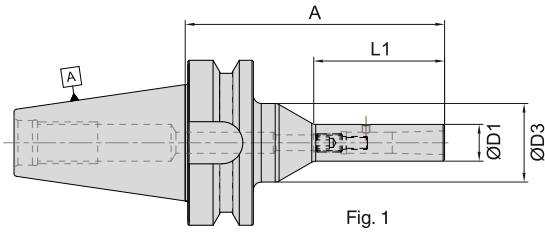

| FBT30 | | | | | | | | | | | |
|---------------------------|------------------|-----------|------------|------------|------------|------------|------------------------------------|------|-------------|----------------------------|-----------|
| Spannzange Collet Type | Bereich Range | A (mm) | L1 (mm) | D1 (mm) | D2 (mm) | D3 (mm) | Kühlmittelzufuhr Coolant supply | Fig. | N/W (Kg) | Bezeichnung Designation | Ident No. |
| MC10 | 3-4 | 90 | 45 | 10 | - | 22 | Form "AD" | 1 | 0,45 | WMCH/D10-90/FBT30 | 5153133 |
| MC14 | 3-6 | 90 | 40 | 14 | - | 30 | Form "AD" | 1 | 0,55 | WMCH/D14-90/FBT30 | 5153134 |
| MC14 | 3-6 | 120 | 70 | 14 | 21.3 | 30 | Form "AD" | 2 | 0,65 | WMCH/D14-120/FBT30 | 5153135 |



| FBT40 | | | | | | | | | | | |
|---------------------------|------------------|-----------|------------|------------|------------|------------|------------------------------------|------|-------------|----------------------------|-----------|
| Spannzange Collet Type | Bereich Range | A (mm) | L1 (mm) | D1 (mm) | D2 (mm) | D3 (mm) | Kühlmittelzufuhr Coolant supply | Fig. | N/W (Kg) | Bezeichnung Designation | Ident No. |
| MC14 | 3-6 | 90 | 40 | 14 | - | 30 | Form "AD" | 1 | 0,55 | WMCH/D14-90/FBT40 | 5153136 |
| MC14 | 3-6 | 120 | 70 | 14 | 21.3 | 30 | Form "AD" | 2 | 1,20 | WMCH/D14-120/FBT40 | 5153138 |



Ersatzteile und Zubehör / Spare Parts & Accessories:

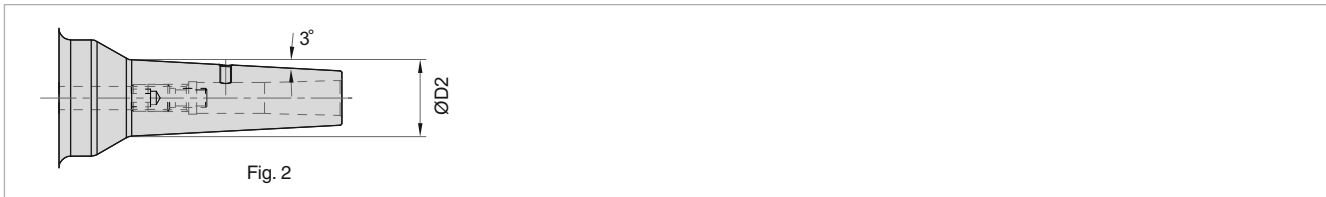

For technical details please refer the technical pages given and also the instruction manual provided in the packing box.

Micro-Spannzangenhalter (SK)

Micro collet holder (SK)

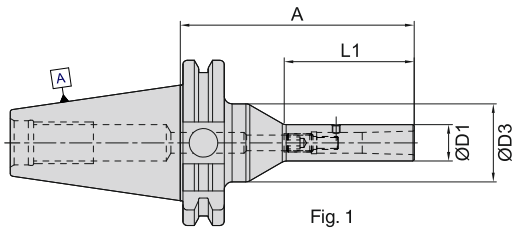

Fig. 1



| SK40 | | | | | | | | | | | | | | | |
|---------------------------|------------------|-----------|------------|------------|------------|------------|-------------------------------------|------|-------------|----------------------------|-----------|--|--|--|--|
| Spannzange Collet Type | Bereich Range | A (mm) | L1 (mm) | D1 (mm) | D2 (mm) | D3 (mm) | Kühlmittelezufuhr Coolant supply | Fig. | N/W (Kg) | Bezeichnung Designation | Ident No. | | | | |
| MC14 | 3-6 | 90 | 40 | 14 | - | 30 | Form "AD" | 1 | 0,95 | WMCH/D14-90/FSK40 | 5153139 | | | | |
| MC14 | 3-6 | 120 | 70 | 14 | 21.3 | 30 | Form "AD" | 2 | 1,05 | WMCH/D14-120/FSK40 | 5153140 | | | | |

Steilkegel mit Plananlage (FSK) / All holders are FSK - Face contact holders (dual contact).

Ersatzteile und Zubehör / Spare Parts & Accessories:

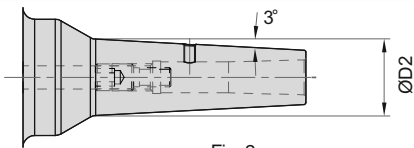
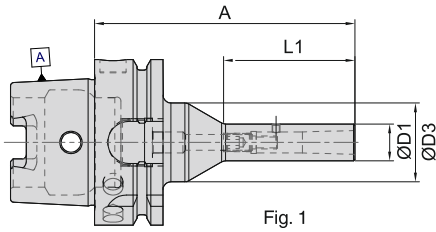

Fig. 2

For technical details please refer the technical pages given and also the instruction manual provided in the packing box.

Micro-Spannzangenhalter (HSK)

Micro collet holder (HSK)



| HSK-A50 | | | | | | | | | | | |
|---------------------------|------------------|-----------|------------|------------|------------|------------|------------------------------------|------|-------------|----------------------------|-----------|
| Spannzange Collet Type | Bereich Range | A (mm) | L1 (mm) | D1 (mm) | D2 (mm) | D3 (mm) | Kühlmittelzufuhr Coolant supply | Fig. | N/W (Kg) | Bezeichnung Designation | Ident No. |
| MC10 | 3-4 | 90 | 45 | 10 | - | 22 | Form "AD" | 1 | 0,45 | WMCH/D10-90/HSK-A50 | 5153141 |
| MC14 | 3-6 | 90 | 40 | 14 | - | 30 | Form "AD" | 2 | 0,50 | WMCH/D14-90/HSK-A50 | 5153142 |

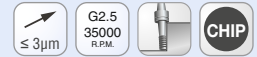

| HSK-A63 | | | | | | | | | | | |
|---------------------------|------------------|-----------|------------|------------|------------|------------|------------------------------------|------|-------------|----------------------------|-----------|
| Spannzange Collet Type | Bereich Range | A (mm) | L1 (mm) | D1 (mm) | D2 (mm) | D3 (mm) | Kühlmittelzufuhr Coolant supply | Fig. | N/W (Kg) | Bezeichnung Designation | Ident No. |
| MC14 | 3-6 | 90 | 40 | 14 | - | 30 | Form "AD" | 1 | 0,80 | WMCH/D14-90/HSK-A63 | 5153143 |
| MC14 | 3-6 | 120 | 70 | 14 | 21.3 | 30 | Form "AD" | 2 | 0,90 | WMCH/D14-120/HSK-A63 | 5153144 |

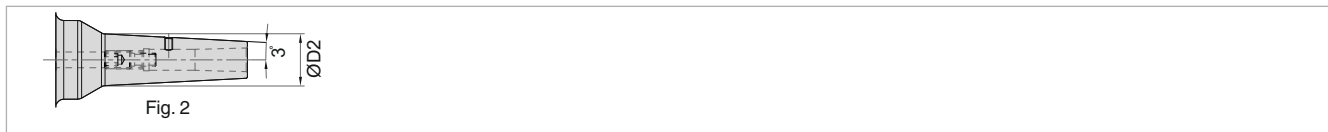

Micro-Spannzangenhalter (HSK-E)

Micro collet holder (HSK-E)

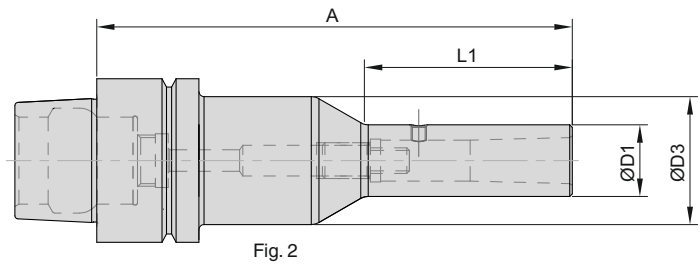
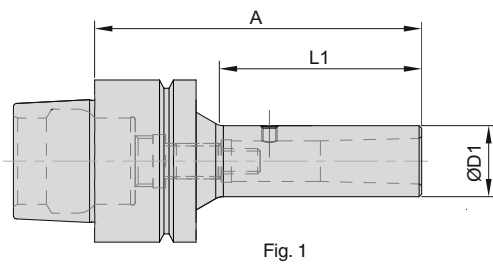

| HSK-E32 | | | | | | | | | | | |
|---------------------------|------------------|-----------|------------|------------|------------|------------|------------------------------------|------|-------------|----------------------------|-----------|
| Spannzange Collet Type | Bereich Range | A (mm) | L1 (mm) | D1 (mm) | D2 (mm) | D3 (mm) | Kühlmittelzufuhr Coolant supply | Fig. | N/W (Kg) | Bezeichnung Designation | Ident No. |
| MC14 | 3-4 | 65 | 40 | 14 | - | - | Form "AD" | 1 | 0,25 | WMCH/D14-65/HSK-E32 | 5167343 |
| MC14 | 3-6 | 90 | 40 | 14 | - | 25 | Form "AD" | 2 | 0,35 | WMCH/D14-90/HSK-E32 | 5167344 |



| HSK-E40 | | | | | | | | | | | |
|---------------------------|------------------|-----------|------------|------------|------------|------------|------------------------------------|------|-------------|----------------------------|-----------|
| Spannzange Collet Type | Bereich Range | A (mm) | L1 (mm) | D1 (mm) | D2 (mm) | D3 (mm) | Kühlmittelzufuhr Coolant supply | Fig. | N/W (Kg) | Bezeichnung Designation | Ident No. |
| MC14 | 3-4 | 65 | 40 | 14 | - | - | Form "AD" | 1 | 0,35 | WMCH/D14-65/HSK-E40 | 5167346 |
| MC14 | 3-6 | 90 | 40 | 14 | - | 30 | Form "AD" | 2 | 0,40 | WMCH/D14-90/HSK-E40 | 5167347 |



For technical details please refer the technical pages given and also the instruction manual provided in the packing box.

Micro Spannzange Verlängerungen
Micro collet extensions

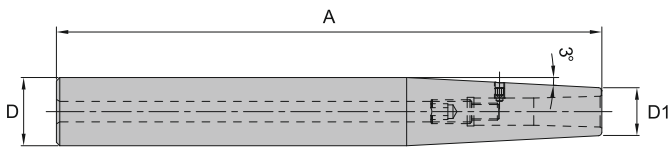

| Spannzange Collet Type | Bereich Ø Range Ø | A (mm) | D (mm) | D1 (mm) | Bezeichnung Designation | Ident No. |
|---------------------------|----------------------|-----------|-----------|------------|----------------------------|-----------|
| MC10 | 3 - 4 | 120 | 12 | 10 | WMCE/D10-120/CYL12 | 5173482 |
| MC14 | 3 - 6 | 90 | 16 | 14 | WMCE/D14-90/CYL16 | 5173483 |
| MC14 | 3 - 6 | 120 | 16 | 14 | WMCE/D14-120/CYL16 | 5173490 |
| MC14 | 3 - 6 | 160 | 16 | 14 | WMCE/D14-160/CYL16 | 5173492 |
| MC14 | 3 - 6 | 200 | 16 | 14 | WMCE/D14-200/CYL16 | 5173497 |
| MC14 | 3 - 6 | 120 | 20 | 14 | WMCE/D14-120/CYL20 | 5173493 |
| MC14 | 3 - 6 | 160 | 20 | 14 | WMCE/D14-160/CYL20 | 5173495 |
| MC14 | 3 - 6 | 200 | 20 | 14 | WMCE/D14-200/CYL20 | 5173496 |

Micro Spannzange
Micro collet

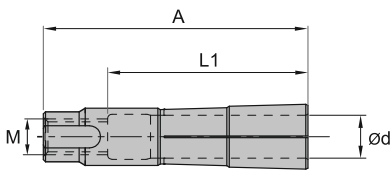

| für Größe for Size | d (mm) | A (mm) | L1 (mm) | M (mm) | Spann Schlüssel Wrench | Anzugsmoment Tightening Torque | Bezeichnung Designation | Ident No. |
|-----------------------|-----------|-----------|------------|-----------|---------------------------|-----------------------------------|----------------------------|-----------|
| MC10 | 3 | 18 | 13 | M4 | W-D10x200L-HEX3.0 | 10Nm | WMC 10-3.0 | 5153145 |
| MC10 | 4 | 18 | 13 | M4 | W-D10x200L-HEX3.0 | 10Nm | WMC 10-4.0 | 5153147 |
| MC14 | 3 | 37 | 15 | M7x1 | W-D14x200L-HEX4.0 | 10Nm | WMC 14-3.0 | 5153148 |
| MC14 | 4 | 37 | 15 | M7x1 | W-D14x200L-HEX4.0 | 10Nm | WMC 14-4.0 | 5153149 |
| MC14 | 5 | 37 | 20 | M7x1 | W-D14x200L-HEX4.0 | 10Nm | WMC 14-5.0 | 5153151 |
| MC14 | 6 | 37 | 28 | M7x1 | W-D14x200L-HEX4.0 | 10Nm | WMC 14-6.0 | 5153152 |

Spann Schlüssel
Wrench

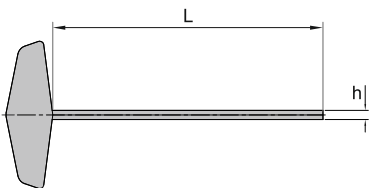

| Bezeichnung Designation | Spannzange Collet Type | h (mm) | L (mm) | Ident No. |
|----------------------------|---------------------------|-----------|-----------|-----------|
| W-D10x200L-HEX3.0 | MC10 | 3.0 | 200 | 5166591 |
| W-D14x200L-HEX4.0 | MC14 | 4.0 | 200 | 5166592 |



**BILZ WERKZEUGFABRIK
GmbH & Co. KG**
Vogelsangstr. 8
73760 Ostfildern
Deutschland / Germany
Telefon +49 711 348 01 - 0
Telefax +49 711 348 12 56
info@bilz.de
www.bilz.de



台北 02-2703-0193
台中 04-2463-6890



Produktions- und Vertriebsstandorte der LEITZ-Group

Production and sales locations of the LEITZ Group

- **Bilz**
- **Boehlerit**
- **Leitz**