

boehlerit

Rohrbearbeitung
Tube processing

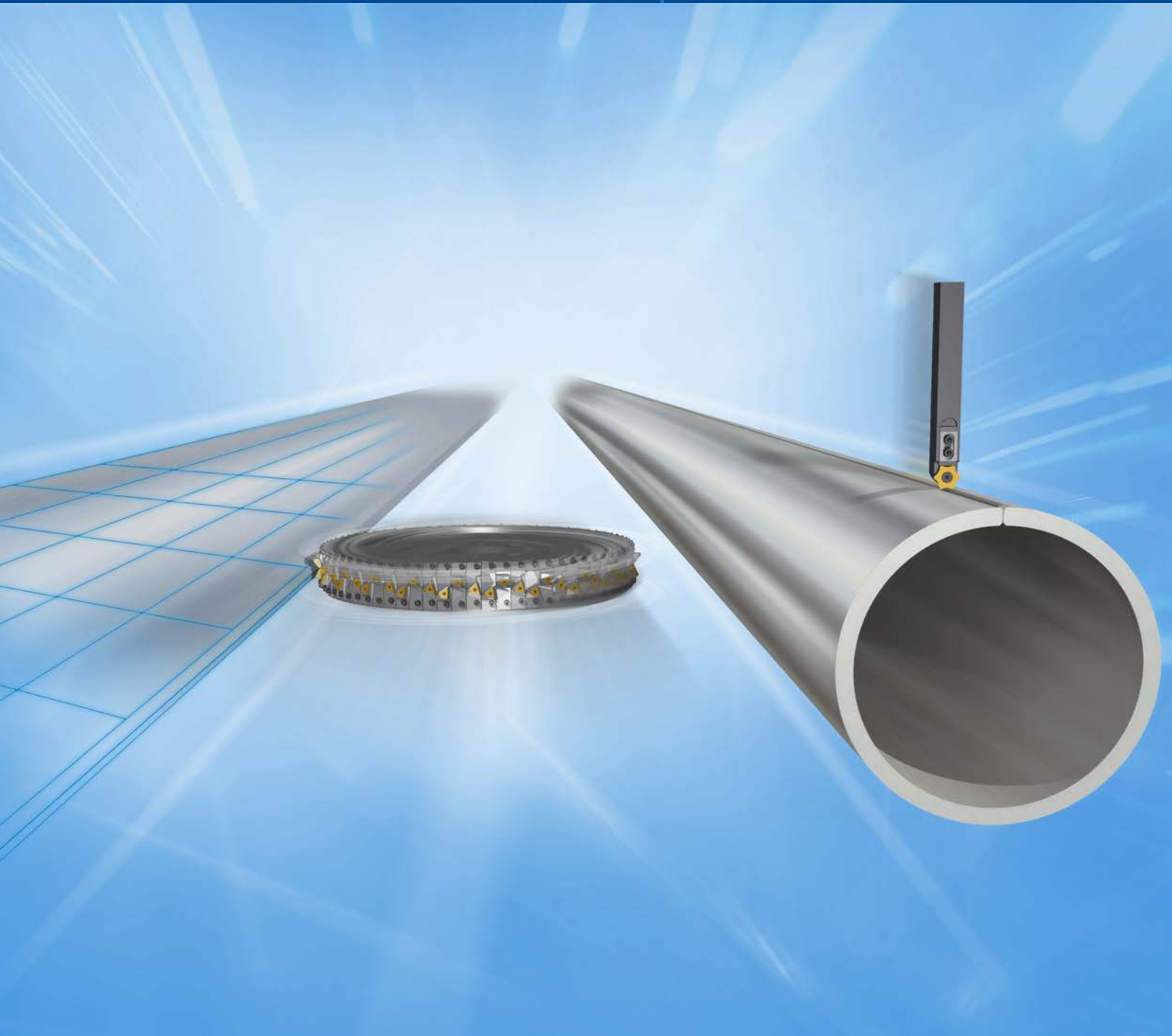

**Boehlerit –
Der Entwicklungspionier im Hartmetall**

Boehlerit, ein familiengeführtes Unternehmen aus der Brucklachergruppe (Leitz, Bilz und Boehlerit) mit Sitz im österreichischen Kapfenberg setzt Maßstäbe mit Hartmetallen und Werkzeugen für die Bearbeitung von Metall, Holz, Kunststoff und Verbundwerkstoffen. Mit Schneidstoffen, Halbzeugen und Präzisionswerkzeugen sowie Werkzeugsystemen zum Fräsen, Drehen, Stechen und Umformen sorgt Boehlerit weltweit für Prozesssicherheit und Effizienz. Zum umfassenden Produktspektrum gehören auch hoch spezialisierte Werkzeuge für die Kurbelwellenbearbeitung sowie für die Hüttentechnik zum Drehschalen, zur Rohr- und Blechbearbeitung sowie der Schwerzerspannung. Das Produktspektrum von Boehlerit umfasst ebenso Hartmetalle für Konstruktionsteile und für den Verschleißschutz. Im Bereich der Beschichtungstechnologie bietet Boehlerit, von der weltweit ersten Nano-CVD Anbindungsschicht bis zur härtesten Diamantschicht, globale Alleinstellung. Darüber hinaus ist Boehlerit mit seinem langjährigen Know-How in der Metallurgie, der Beschichtungstechnologie und mit modernster Presstechnik ein kompetenter Entwicklungspartner für Toolmaker.

**Boehlerit –
Pioneer in carbide development** www.boehlerit.com

Boehlerit, a family business that is part of the Brucklacher group (Leitz, Bilz and Boehlerit) and headquartered in the Austrian town of Kapfenberg, sets global standards with carbides and tools for the processing of metal, wood, plastics and composites. With cutting materials, semi-finished products, precision tools and tool systems for milling, turning, drilling and forming, Boehlerit ensures process safety and efficiency on a global scale. The company's extensive product portfolio includes highly specialised tools for the machining of crankshafts as well as for the mining industry, for bar peeling, tube and sheet metal processing and heavy-duty machining. The Boehlerit product range also features carbides for construction components and wear protection. When it comes to coating technology, Boehlerit occupies a unique position worldwide, ranging from the first-ever nano-CVD bonding layer to the hardest diamond layer worldwide. With its many years' experience in metallurgy, coating technology and state-of-the-art press technology, Boehlerit is a highly competent development partner for toolmakers.



Produktionsstandorte

Der Boehlerit Konzern setzt internationale Qualitätsstandards. In modernsten Produktionsstätten wird jährlich in neue Produktionstechnologien sowie Kapazitätserweiterungen investiert. In Österreich, Deutschland und der Türkei werden die Erkenntnisse aus Forschung und Entwicklung in Qualitätsprodukte umgesetzt.

Production sites

The Boehlerit Group sets international quality standards. Every year, the company invests in new production technologies and in the expansion of capacities at its advanced production sites. High-quality products made in Austria, Germany and Turkey incorporate the latest research and development findings.



Boehlerit Kapfenberg (Headquarter)
in der Steiermark/Österreich Styria/Austria



Boehlerit Sert Metal
in Istanbul/Türkei Turkey



Boehlerit Deutschland
in Oberkochen Deutschland/Germany

Technologievorteile, Kundennutzen	Technological advantages, customer benefits	4
Schneidstoffsortenübersicht	Grade overview	6
Sortenbeschreibung	Grade description	7
Bezeichnungssystem, Ersatzteile - Schrauben	Designation system, Spare parts - Screws	8
ISO-Bezeichnungssystem Wendeschneidplatten	ISO indexable inserts designation	9
Wendeschneidplatten für die Schweißkantenbearbeitung	Weld edge inserts	13
Schweißnahtbearbeitung	Weld seam scarfing	17
Rohrendenbearbeitung	Pipe end beveling	35
Werkzeuge für die Schweißkanten- Schweißnaht - und Rohrendenbearbeitung	Tools for wheel edge processing- weld seam scarfing and pipe end preparing	39
Kooperationspartner NEO TECH Hersteller von Innenschabwerkzeugen	Cooperationspartner NEO TECH producer for internal weld seam scarfing tools	46
BULLtec Turn	BULLtec Turn	47
Planscheibe	Faceplate	48
Kassetten und Ersatzteile zur Rohrendenbearbeitung	Cartridges and spare parts for pipe end beveling	49
Werkzeugauswahl, Bezeichnungssystem, Schnittdaten	Choice of tool, designationsystem, cutting data recommendation	55
Vertriebstöchter und Repräsentanten	Subsidiaries and representatives	

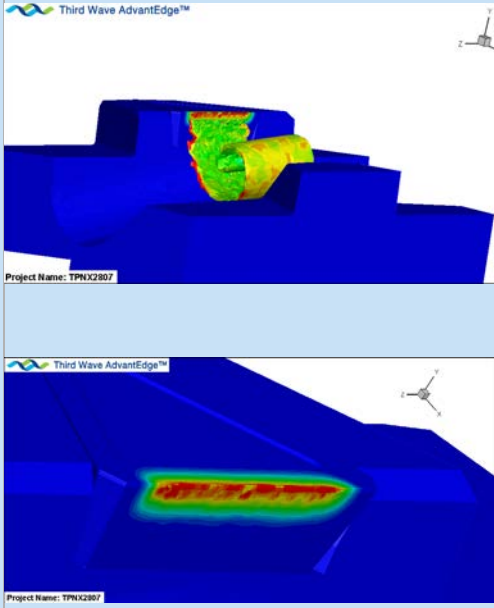

Entwicklung Development

<p>Mit Hilfe einer Finite-Elemente-Analyse Software ist es möglich Werkzeuge schon während der Entwicklung zu überprüfen und auf die Anforderungen des Kunden zu optimieren. In einer Simulation können die Spanform und Schnittkräfte auf Basis der Geometriedaten und mechanischen Werkstoffkenngrößen dargestellt werden. So wird ermöglicht den Fräser auf die maximal mögliche Zähnezahl ausulegen und dennoch einen problemlose Spanabfuhr zu gewährleisten.</p>	<p style="text-align: center;">Simulationsprogramm</p> 	<p>Bei der Finiten-Elemente-Methode handelt es sich um numerisches Berechnungsverfahren. Die Grundidee der FEM besteht darin, ein kontinuierliches Problem in ein diskretes Problem zu überführen, indem das zu untersuchende Gebiet in kleinere Teilbereiche, sogenannte Elemente, unterteilt wird. Dies macht es möglich auch an komplexen Bauteilen Spannungen und Verformungen, elastisch so wie plastisch, für diese Knotenpunkte zu bestimmen.</p> <p>The finite element method is a numerical calculation method. The basic idea of the FEM is to convert a continuous problem into a discrete problem by dividing the area to be analyzed into smaller sub-areas, so-called elements. This makes it possible to determine stresses and deformations, both elastic and plastic, for these nodal points, even on complex components.</p>
<p>With the help of finite element analysis software, it is possible to check tools during development and optimize them to the customer's requirements. The chip shape and cutting forces can be represented in a simulation based on the geometry data and mechanical material parameters. This makes it possible to design the milling cutter for the maximum possible number of teeth and still ensure problem-free chip removal.</p>		

<p>HiPIMS liefert im Vergleich zu anderen PVD-Schichten bessere Bruchresistenz bei gleicher Härte, sowie plus, gleichmäßigere Schichtverteilung um die Schneidkante.</p> <p>Compared to other PVD coatings, HiPIMS provides better break resistance at the same hardness. Plus, more even layer distribution around the cutting edge.</p>		<p>Durch extrem dichte, mikrokristalline und verschleißfeste Schichten können höchste Performance und Prozesssicherheit erzielt werden.</p> <p>Highest performance and process security due to extrem thick microcrystalline and wear resistant layers.</p>
---	--	---

Wendeschneidplatten Inserts

<p>Kundenspezifische Wendeschneidplatte Customized indexable insert</p>		
<p>Anwendungsoptimierte Wendeschneidplatten Application-optimised cutting inserts</p>		<p>Geometrie und Sorte garantieren ökonomischen Einsatz in der Rohr- und Schweißkantenbearbeitung</p> <p>Geometry and grade ensure cost-effective use in pipe and weld edge processing</p>

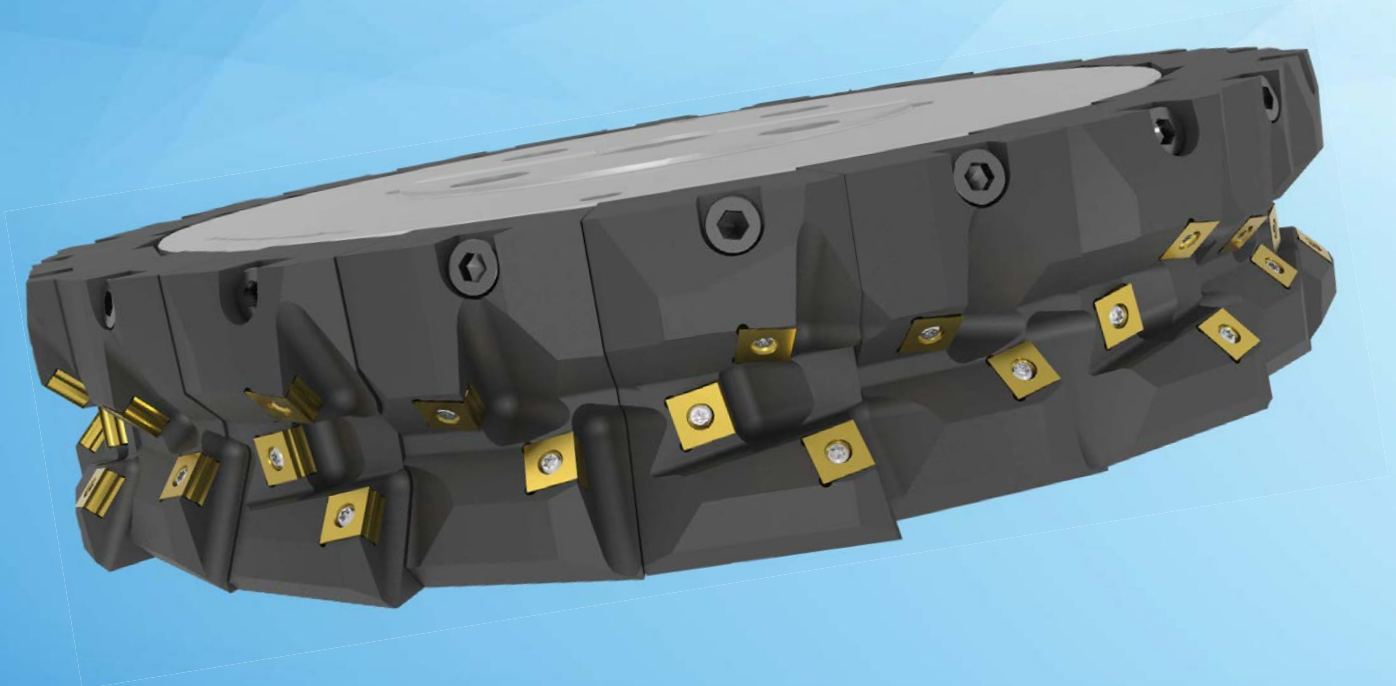

Besondere Merkmale:

- Modulares Werkzeugsystem.
- Durch einfachen Kassettenaustausch können mit einem Grundkörper verschiedene Fräsprofile realisiert werden.
- Rasches und effizientes Umrüsten je nach Anforderung.
- Reduktion der Anzahl von Trägerkörpern und damit Lagerkosten.
- Kassettenaustausch bedarf keiner Justierung, kürzeste Rüstzeiten nach Werkzeugbeschädigung.
- Kundeneinzelanfertigung auf höchstem Niveau.
- Kundenspezifische High End Werkzeuge.
- Exakte Rundlaufeigenschaften sowie Profiltreue auch bei größten Durchmessern.
- Sorgfältig ausgewählte Werkstoffe und Wärmebehandlung garantiert Dauerfestigkeit und damit Ausfallsicherheit über Jahrzehnte.

Special features:

- Modular tool system.
- One base body allows for different milling profiles as the cartridges may be exchanged.
- Fast and efficient retooling according to specific requirements
- Reduction of the number of carriers and thus also storage costs
- No adjustment is required when an cartridge needs to be changed, reduced downtime due to damaged tools
- Custom manufacturing at the highest level.
- Customer-specific high-end tools
- Precise true-running characteristics and profile accuracy even for biggest diameters.
- Carefully selected materials and heat treatments guarantee endurance strength and thus fail-safe operation over decades

Schneidstoffsorten Übersicht

Grade overview

Sorte Grade	ISO	Anwendungsbereich Application range	Werkstoffgruppe Material group						Bearbeitungsverfahren Application			Farbliche Darstellung der WSP je nach Beschichtung Color guide for inserts depending on coating
			P Stahl Steel	M Rostfrei Stainless	K Grauguss Grey cast iron	N NE-Metalle Non-ferrous metals	S Hochwarmfest High tempera- ture materials	H Harte Werkstoffe Hard materials	E / M Band- kanten- fräsen Edge milling	S Scha- ben Scar- fing	B Rohr- enden- bear- beitung Bevelling	
BCP30E	HC-P30		■						●			
	HC-M30			■								
BCP37M	HC-P40		■						●			
BCP40M	HC-P40		■						●			
	HC-M40			■								
BCM40M	HC-M40			■					●			
	HC-S40						■					
BCP15S	HC-P15		■									
	HC-M15			■						●		
	HC-N15					■						
BCP25S	HC-P25		■								●	
	HC-M25			■								
BCP35S	HC-P35		■							●		
BCP39S	HC-P40		■							●		
BCP41S	HC-P40		■							●		
BCP25B	HC-P25		■									
	HC-M25			■							●	
BCM25B	HC-M25			■								
	HC-S25						■				●	

Anwendungsschwerpunkt
Application peak

Gesamtbereich nach ISO 513
Full range to ISO 513

■ Hauptanwendung
Main application

□ Weitere Anwendungen
Further applications

● Standardsorte
Standard grade

Änderung der Sortenbezeichnung

Change of grade designation

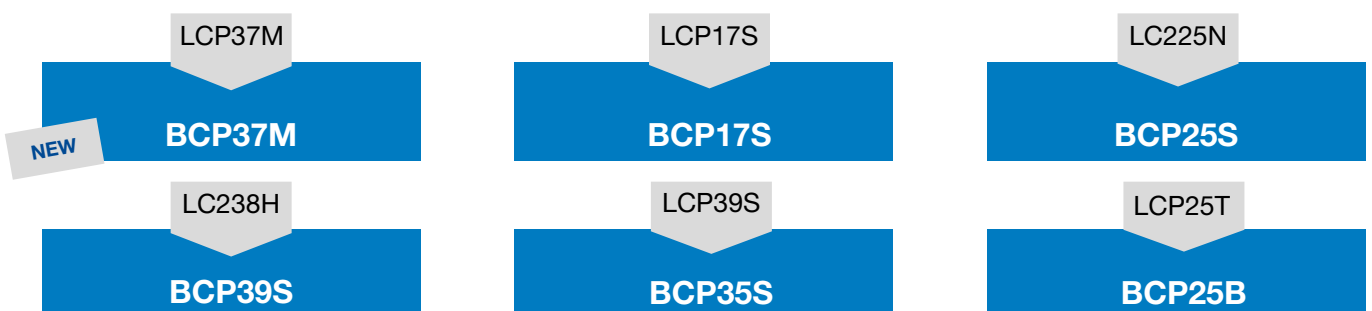

● **BCP30E (HC-P30 HC-M30)**

Universelle Stahlfrässorte für hohe Bearbeitungssicherheit auf einem breiten Stahlwerkstoffspektrum, garantiert durch das besonders zähe Hartmetallsubstrat. Die PVD Beschichtung kann durch sorgfältig abgestimmte Beschichtungsparameter besonders dick abgeschieden werden, was die Risempfindlichkeit erheblich reduziert.

● **BCP37M (HC-P40)**

Universelle Frässorte, Hauptsorte zum Schruppen von legierten, unlegierten bzw. rostbeständigen Stahlwerkstoffen. Ein Großteil der zur Rohrherstellung verwendeten Werkstoffe, kann mit dieser Sorte höchst wirtschaftlich zerspannt werden.

● **BCP40M (HC-P40, HC-M40)**

Eine PVD Schicht und zähe Hartmetallsorte zum Schruppen von vor allem Werkzeug-, Vergütungs-, Einsatzstählen und austenitisch, rostfreien Materialien.

● **BCM40M (HC-M40, HC-S40)**

Extrem zähes, relativ feinkörniges Hartmetallsubstrat mit dünner, glatter PVD Beschichtung. Ideale Sorte zum Fräsen von austenitisch rostfreien Stählen und Werkstoffen aus der Duplexgruppe mit niedrigen bis mittleren Schnittgeschwindigkeiten. Auch für die Nassbearbeitung, jedoch wird Minimalmengenschmierung empfohlen. Sorten zum Schaben

● **BCP15S (HC-P15, HC-M15, HC-N15)**

Schwerzerspannungssorte welche sehr gut geeignet ist für niedrig bis hochlegierte und rostbeständigen Stählen bei hohen Schnittgeschwindigkeiten

● **BCP25S (HC-P25, HC-M25)**

Schwerzerspannungssorte welche gut geeignet ist für niedrig bis hochlegierte und rostbeständigen Stählen bei mittleren Schnittgeschwindigkeiten

● **BCP35S (HC-P35)**

Hochzähe Sorte besonders geeignet für den Dauerschnitt beim Schaben. Das feine Grundsubstrat in Kombination mit der AlTiN Beschichtung gewährleisten hohe Abrasionsbeständigkeit und Ausbruchssicherheit bei höchster Temperaturbeständigkeit.

● **BCP39S (HC-P40)**

Hochzähe Sorte besonders geeignet für den Dauerschnitt beim Schaben. Das grobe Grundsubstrat in Kombination mit einer CVD Beschichtung gewährleisten gute Performance bei höchsten Temperaturen

● **BCP41S (HC-P40)**

Sorte für die Bearbeitung von unlegiertem und legiertem Stahl bei mittleren Schnittgeschwindigkeit. Zähes Hartmetallsubstrat für Ausbruchssicherheit auch bei kurzfristig unterbrochenem Schnitt, kombiniert mit temperaturbeständiger Beschichtung. Sorten zur Rohrendenbearbeitung

● **BCP25B (HC-P25, HC-M25)**

(Universelle Drehsorte) Hauptsorte zum Drehen von Stahlwerkstoffen und leicht zerspanbarem, rostbeständigem Stahl, bei mittleren Schnittgeschwindigkeiten, auch bei unterbrochenem Schnitt. Diese Mehrbereichssorte zeichnet sich durch hohe Verschleißfestigkeit und ausgezeichnete Zähigkeitseigenschaften in einem breiten Einsatzspektrum aus.

● **BCM25B (HC-M25, HC-S25)**

Hauptsorte für die Rostfreibearbeitung. Äußerst gut geeignet für die Bearbeitung von säurebeständigen Materialien.

● **BCP30E (HC-P30 HC-M30)**

Universal steel milling grade for high machining safety on a wide range of steelgrades, guaranteed by the particularly tough substrate. The PVD coating is deposited extraordinary thick by special coating parameters, which significantly reduces cracking sensitivity

● **BCP37M (HC-P40)**

Universal milling grade, main grade for roughing of alloyed, unalloyed respectively rust-resistant steel materials. The majority of the used materials for the production of tubes can be machined very economically with this grade.

● **BCP40M (HC-P40)**

PVD-layer and tough carbide grade for roughing of mainly tool, heat-treated and case-hardened steels, as well as austenitic, stainless materials

● **BCM40M (HC-M40, HC-S40)**

Extremely tough, relative fine grained carbide substrate with thin, smooth PVD coating. Ideal grade for milling of austenitic stainless steels and materials from the Duplex group with low to medium cutting speeds. Also for wet machining, although minimum coolant supply is recommended.

● **BCP15S (HC-P15, HC-M15, HC-N15)**

Grade for heavy duty machining, very good suitable for low to high alloyed steels and stainless steels at high cutting speeds.

● **BCP25S (HC-P25, HC-M25)**

Grade for heavy duty machining, good suitable for low to high alloyed steels and stainless steels at medium cutting speeds.

● **BCP35S (HC-P35)**

Heavy-duty grade particularly well suited for a continuous cut and/or briefly interrupted cut in scraping operations. The fine base substrate in combination with the AlTiN coat ensures high abrasion and chipping resistance as well as optimum temperature resistance.

● **BCP39S (HC-P40)**

Heavy-duty grade particularly well suited for a continuous cut in scraping operations. The coarse base substrate in combination with the CVD coating ensures high performance for high temperatures

● **BCP41S (HC-P40)**

Grade for machining of unalloyed and alloyed steel with medium cutting speed. Tough carbide substrate for breakage security also on short interrupted cut, combined with temperature resistant coating.

● **BCP25B (HC-P25, HC-M25)**

(Universal turning grade) Main grade for machining steel materials and easily machinable stainless steels at medium cutting speeds, included interrupted cut. This general purpose grade is characterized by the properties of high wear resistance and excellent characteristics across a wide range of applications

● **BCM25B (HC-M25, HC-S25)**

Main grade for stainless machining. Extremely good applicable for the machining of acid proofed materials.

Schneidstoffsorten, Bezeichnung für Wendeschneidplatten
Cutting materials, designation system for indexable inserts

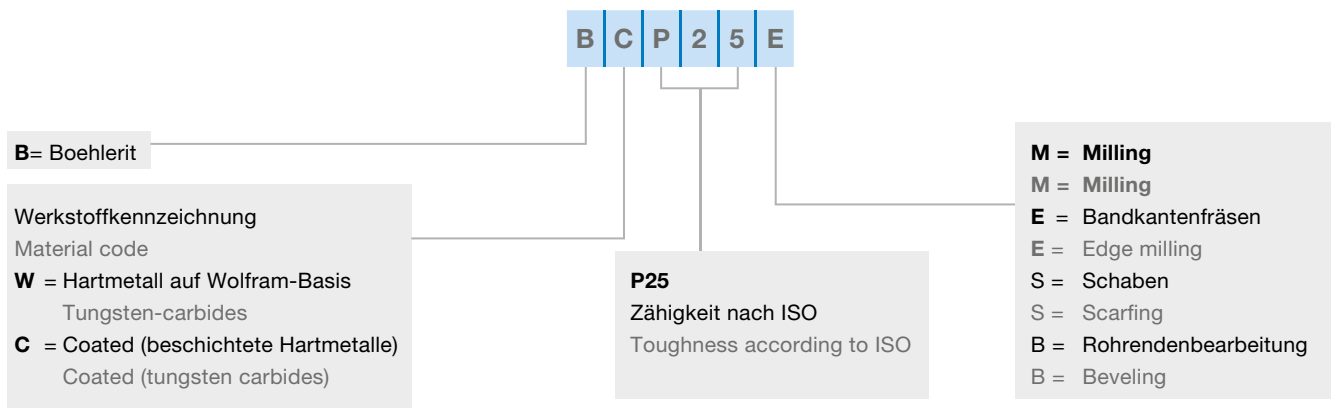



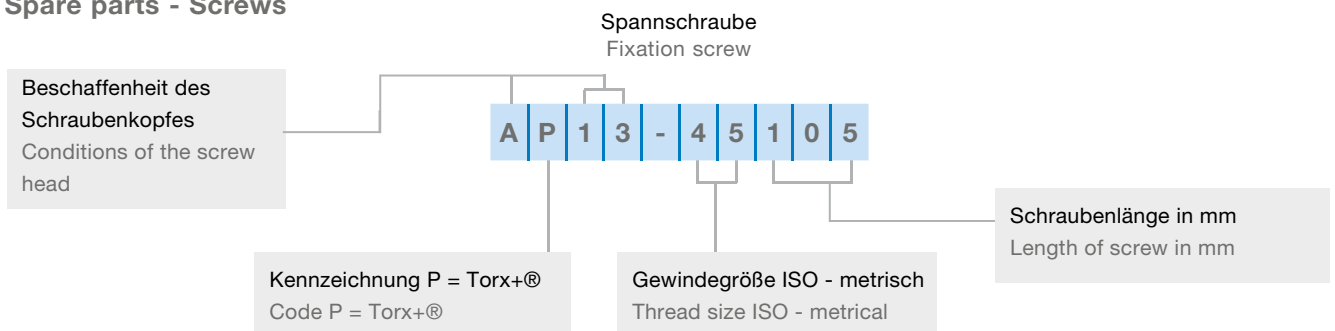







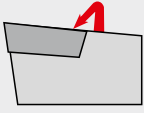

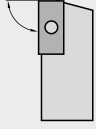
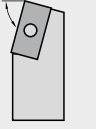
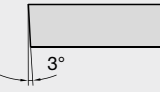
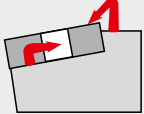

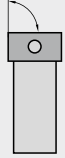
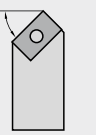
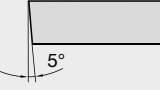
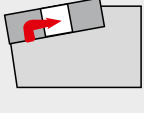



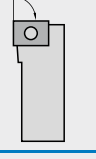
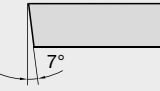
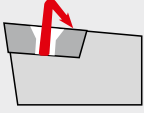

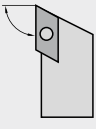
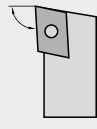
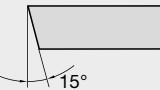

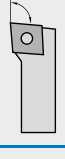
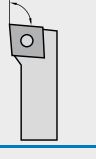



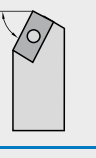
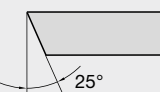



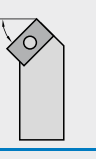
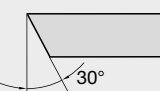

Ersatzteile - Schrauben
Spare parts - Screws

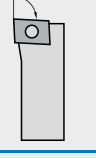
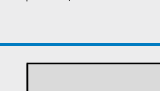

Ersatzteile Spare parts				Frässystem Milling system		
Artikelbezeichnung Item code	Bestell-Nr. Ordering No.	Montage- werkzeug Mounting tool	Anzugs- moment Torque	Edge Milling	Scarfig	Beveling
A02-30076	5084082	T9	2 Nm	•		
A02-40108	6401263	T15	3 Nm		•	
A02-50130	5090952	T20	5 Nm	•		•
A02-50160	5049762	T20	5 Nm		•	
A02-60160	6401270	T25	6 Nm	•	•	
A02-80250	6401272	T25	20 Nm		•	•
A03-08235	6401282	Innensechskant SW3 Hexagon socket AF3	20 Nm		•	
A03-10270	6401283	Innensechskant SW4 Hexagon socket AF4	20 Nm		•	
A03-12360	6401285	Innensechskant SW5 Hexagon socket AF5	20 Nm		•	
A06-45120	6401291	T15	4 Nm	•		
A07-40120	6401295	T9	3 Nm		•	
DIN7991 M5x12	6406150	Innensechskant SW3 Hexagon socket AF3	6 Nm	•		
DIN7991 M8x25	5088671	Innensechskant SW5 Hexagon socket AF5	20 Nm	•		
DIN7991 M5x16	6412644	Innensechskant SW3 Hexagon socket AF3	6 Nm		•	
DIN912 M5x12	6406151	Innensechskant SW4 Hexagon socket AF4	6 Nm		•	
A02-T5015	6401252	TX20	5 Nm	•		

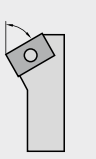
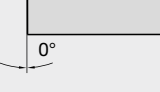
S Grundform Insert shape	N Freiwinkel Clearance angle	M Toleranzen Tolerances	X Spanformer, Befestigung Chip breaker, fixation	12 Schneidenlänge Cutting edge length	06 Dicke Thickness																																																																														
A	85°	<table border="1"> <tr><td></td><td>m</td><td>s</td><td>d</td></tr> <tr><td>A</td><td>±0,005</td><td>±0,025</td><td>±0,025</td></tr> <tr><td>C</td><td>±0,013</td><td>±0,025</td><td>±0,025</td></tr> <tr><td>E</td><td>±0,025</td><td>±0,025</td><td>±0,025</td></tr> <tr><td>F</td><td>±0,005</td><td>±0,025</td><td>±0,013</td></tr> <tr><td>G</td><td>±0,025</td><td>±0,13</td><td>±0,025</td></tr> <tr><td>H</td><td>±0,013</td><td>±0,025</td><td>±0,013</td></tr> <tr><td>J</td><td>±0,005</td><td>±0,025</td><td>siehe see Tab. 4</td></tr> <tr><td>K</td><td>±0,013</td><td>±0,025</td><td>siehe see Tab. 4</td></tr> <tr><td>L</td><td>±0,025</td><td>±0,025</td><td>siehe see Tab. 4</td></tr> <tr><td>M</td><td>siehe see Tab. 5</td><td>±0,13</td><td>siehe see Tab. 4</td></tr> <tr><td>N</td><td>siehe see Tab. 5</td><td>±0,025</td><td>siehe see Tab. 4</td></tr> <tr><td>U</td><td>siehe see Tab. 5</td><td>±0,13</td><td>siehe see Tab. 4</td></tr> </table>		m	s	d	A	±0,005	±0,025	±0,025	C	±0,013	±0,025	±0,025	E	±0,025	±0,025	±0,025	F	±0,005	±0,025	±0,013	G	±0,025	±0,13	±0,025	H	±0,013	±0,025	±0,013	J	±0,005	±0,025	siehe see Tab. 4	K	±0,013	±0,025	siehe see Tab. 4	L	±0,025	±0,025	siehe see Tab. 4	M	siehe see Tab. 5	±0,13	siehe see Tab. 4	N	siehe see Tab. 5	±0,025	siehe see Tab. 4	U	siehe see Tab. 5	±0,13	siehe see Tab. 4	A	<table border="1"> <tr><td></td><td>l</td></tr> <tr><td>06</td><td>6,350</td></tr> <tr><td>07</td><td>7,938</td></tr> <tr><td>09</td><td>9,525</td></tr> <tr><td>11</td><td>11,000</td></tr> <tr><td>12</td><td>12,700</td></tr> <tr><td>15</td><td>15,875</td></tr> <tr><td>16</td><td>16,500</td></tr> <tr><td>19</td><td>19,050</td></tr> <tr><td>22</td><td>22,000</td></tr> <tr><td>25</td><td>25,400</td></tr> <tr><td>31</td><td>31,750</td></tr> <tr><td>38</td><td>38,100</td></tr> </table>		l	06	6,350	07	7,938	09	9,525	11	11,000	12	12,700	15	15,875	16	16,500	19	19,050	22	22,000	25	25,400	31	31,750	38	38,100	
	m	s	d																																																																																
A	±0,005	±0,025	±0,025																																																																																
C	±0,013	±0,025	±0,025																																																																																
E	±0,025	±0,025	±0,025																																																																																
F	±0,005	±0,025	±0,013																																																																																
G	±0,025	±0,13	±0,025																																																																																
H	±0,013	±0,025	±0,013																																																																																
J	±0,005	±0,025	siehe see Tab. 4																																																																																
K	±0,013	±0,025	siehe see Tab. 4																																																																																
L	±0,025	±0,025	siehe see Tab. 4																																																																																
M	siehe see Tab. 5	±0,13	siehe see Tab. 4																																																																																
N	siehe see Tab. 5	±0,025	siehe see Tab. 4																																																																																
U	siehe see Tab. 5	±0,13	siehe see Tab. 4																																																																																
	l																																																																																		
06	6,350																																																																																		
07	7,938																																																																																		
09	9,525																																																																																		
11	11,000																																																																																		
12	12,700																																																																																		
15	15,875																																																																																		
16	16,500																																																																																		
19	19,050																																																																																		
22	22,000																																																																																		
25	25,400																																																																																		
31	31,750																																																																																		
38	38,100																																																																																		
B	82°	F	02 2,38																																																																																
C	80°	G	03 3,18																																																																																
D	55°	H	T3 3,97																																																																																
E	75°	J	04 4,76																																																																																
H	A 3°	K	05 5,56																																																																																
K	B 5°	L	06 6,35																																																																																
L	C 7°	M	07 7,94																																																																																
M	D 15°	N	08 8,00																																																																																
O	E 20°	Q	09 9,52																																																																																
P	F 25°	R	Abmessungen in mm Dimensions in mm																																																																																
R	G 30°	T																																																																																	
S	N 0°	U																																																																																	
T	P 11°	W																																																																																	
V	O																																																																																		
W	Normalfreiwinkel, die eine besondere Beschreibung erfordern. Normal clearance angles, which require a special description.	Tab. 4 <table border="1"> <tr><td></td><td>d</td><td>J, K, L, M</td><td>d</td><td>U</td></tr> <tr><td>über</td><td>bis</td><td></td><td></td><td></td></tr> <tr><td>over</td><td>up to</td><td></td><td></td><td></td></tr> <tr><td>3,9</td><td>10,0</td><td>±0,05</td><td></td><td>±0,08</td></tr> <tr><td>10,0</td><td>15,0</td><td>±0,08</td><td></td><td>±0,13</td></tr> <tr><td>15,0</td><td>20,0</td><td>±0,10</td><td></td><td>±0,18</td></tr> <tr><td>20,0</td><td>26,0</td><td>±0,13</td><td></td><td>±0,25</td></tr> <tr><td>26,0</td><td>32,0</td><td>±0,15</td><td></td><td>±0,25</td></tr> </table>		d	J, K, L, M	d	U	über	bis				over	up to				3,9	10,0	±0,05		±0,08	10,0	15,0	±0,08		±0,13	15,0	20,0	±0,10		±0,18	20,0	26,0	±0,13		±0,25	26,0	32,0	±0,15		±0,25																																									
	d	J, K, L, M	d	U																																																																															
über	bis																																																																																		
over	up to																																																																																		
3,9	10,0	±0,05		±0,08																																																																															
10,0	15,0	±0,08		±0,13																																																																															
15,0	20,0	±0,10		±0,18																																																																															
20,0	26,0	±0,13		±0,25																																																																															
26,0	32,0	±0,15		±0,25																																																																															
		Tab. 5 <table border="1"> <tr><td></td><td>d</td><td>M, N</td><td>m</td><td>U</td></tr> <tr><td>über</td><td>bis</td><td></td><td></td><td></td></tr> <tr><td>over</td><td>up to</td><td></td><td></td><td></td></tr> <tr><td>3,9</td><td>10,0</td><td>±0,08</td><td></td><td>±0,13</td></tr> <tr><td>10,0</td><td>15,0</td><td>±0,13</td><td></td><td>±0,20</td></tr> <tr><td>15,0</td><td>20,0</td><td>±0,15</td><td></td><td>±0,27</td></tr> <tr><td>20,0</td><td>26,0</td><td>±0,18</td><td></td><td>±0,38</td></tr> <tr><td>26,0</td><td>32,0</td><td>±0,20</td><td></td><td>±0,38</td></tr> </table>		d	M, N	m	U	über	bis				over	up to				3,9	10,0	±0,08		±0,13	10,0	15,0	±0,13		±0,20	15,0	20,0	±0,15		±0,27	20,0	26,0	±0,18		±0,38	26,0	32,0	±0,20		±0,38																																									
	d	M, N	m	U																																																																															
über	bis																																																																																		
over	up to																																																																																		
3,9	10,0	±0,08		±0,13																																																																															
10,0	15,0	±0,13		±0,20																																																																															
15,0	20,0	±0,15		±0,27																																																																															
20,0	26,0	±0,18		±0,38																																																																															
26,0	32,0	±0,20		±0,38																																																																															
		Eckenrundung, ungerade Seitenzahl Corner rounding uneven number of sides 																																																																																	
		Eckenrundung, gerade Seitenzahl Corner rounding, even number of sides 																																																																																	
		Fasenplatten Chamfered inserts 																																																																																	
		Der Eckenwinkel ist bei ungleichwinkligen Grundformen immer der kleinere Winkel. The corner angle is in the case of not equiangular basic forms always the smaller angle.	X mit Besonderheit nach Zeichnung with special feature according to drawing																																																																																

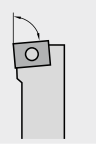
() Kegelwinkel für Schraube
() Cone angle for screw

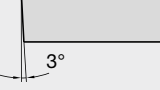
P Befestigungsart Type of fixation	C Wendeschneidplattenform Indexable insert shape	L Klemmhalterform Tool holder shape	N Wendeschneidplattenfreiwinkel Insert clearance angle
C  Von oben geklemmt Fixation from above	A  85° B  82°	A  90° B  75°	A  3°
M  Von oben und über Bohrung geklemmt Fixation from above and through a hole	C D  80° E  55°	C  90° D  45°	B  5°
P  Über Bohrung geklemmt Fixation through a hole	F  75° H  120°	E  60° F  90°	C  7°
S  Durch Bohrung geschraubt Fixation by screw through a conical hole	K  55° L  90°	G  90° J  93°	D  15°
	M  86° O  135°	H  107,5° L  95°	E  20°
	P  108° R  -	K  75° N  63°	F  25°
	S  90° T  60°	M  50° S  45°	G  30°
	V  35° W  80°	R  75° U  93°	P  11°
	T  60° W  60°	T  60° W  60°	N  0°
	V  72,5°	V  72,5° Y  85°	O  3°
			O  3° Freiwinkel, bei denen besondere Angaben erforderlich sind Clearance angle requiring special indication

R
Schnittrichtung
Cutting direction

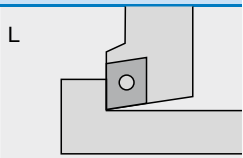

Klemmhalter kann nur linksschneidend verwendet werden
The tool holder can only be used for cuts to the left

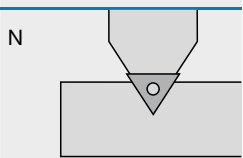

Klemmhalter kann rechts- und linksschneidend verwendet werden
The tool holder can be used for cuts either to the left or to the right

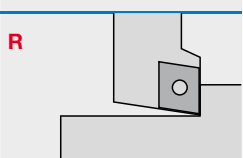

Klemmhalter kann nur rechtsschneidend verwendet werden
The tool holder can only be used for cuts to the right

25
Schneidenhöhe
Cutting height

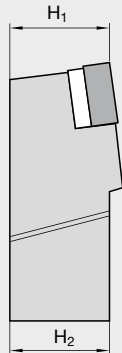

Bei Klemmwerkzeugen entspricht die Schneidenhöhe (h_1) im allgemeinen der Schafthöhe (h_2). Ausgenommen sind Kurzklemmhalter und Klemmwerkzeuge zum Innendrehen.
For clamped tools, the cutting height (h_1) generally corresponds to the shaft height (h_2). The exceptions to this include cartridge toolholders and clamped tools for internal turning.

25
Schaftbreite
Shank width

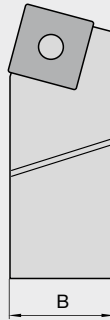

M
Werkzeuglänge
Tool length

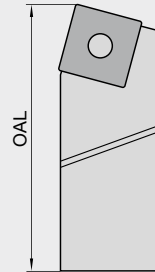

Kennbuchstaben für die Längen l_1
Code letters for the length l_1

A	32 mm
B	40 mm
C	50 mm
D	60 mm
E	70 mm
F	80 mm
G	90 mm
H	100 mm
J	110 mm
K	125 mm
L	140 mm
M	150 mm
N	160 mm
P	170 mm
Q	180 mm
R	200 mm
S	250 mm
T	300 mm
U	350 mm
V	400 mm
W	450 mm
X	Sonderlänge Special length
Y	500 mm

12
Schneidkantenlänge
Cutting edge length

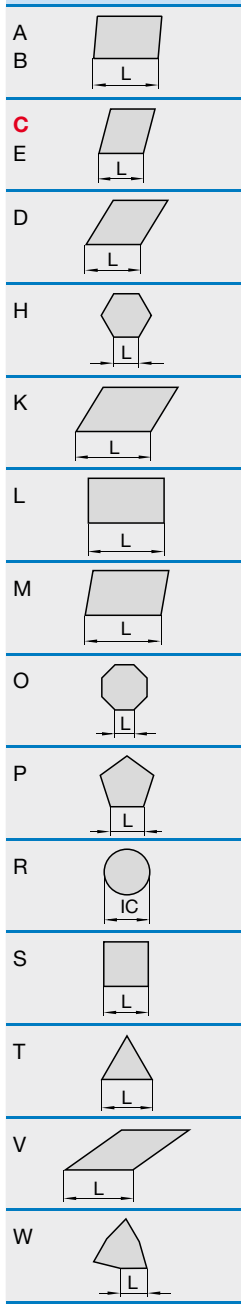

- Beispiele:**
Examples:
- 06 L = 6,350 mm
 - 09 L = 9,525 mm
 - 11 L = 11,000 mm
 - 12 L = 12,700 mm**
 - 15 L = 15,880 mm
 - 16 L = 16,500 mm
 - 19 L = 19,050 mm
 - 22 L = 22,000 mm
 - 25 L = 25,400 mm
 - 27 L = 27,500 mm
 - 33 L = 33,000 mm

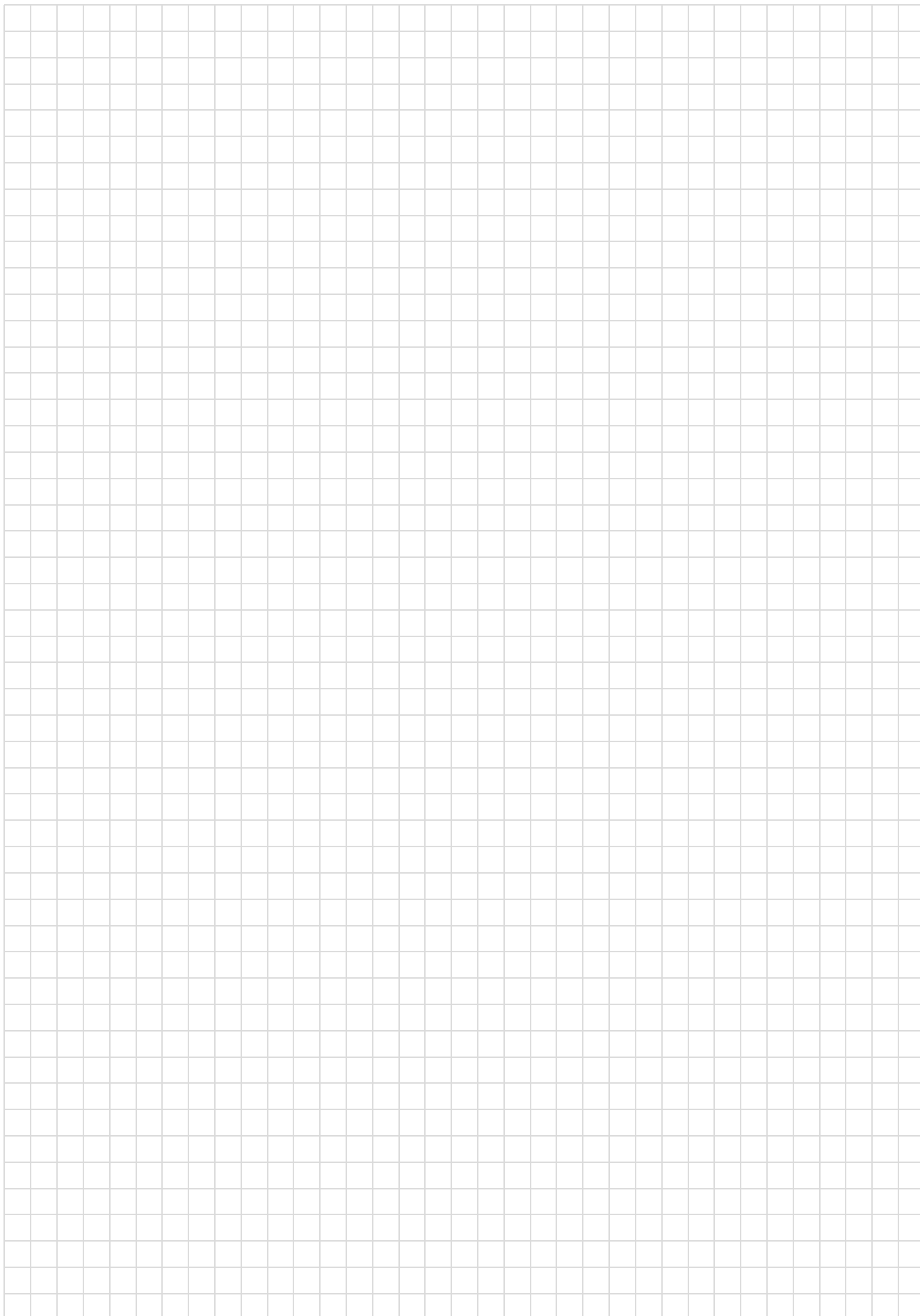

Wendeschneidplatten für die
Schweißkantenbearbeitung
Weld edge inserts
processing

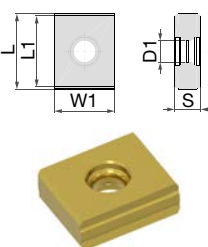
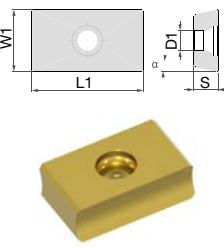
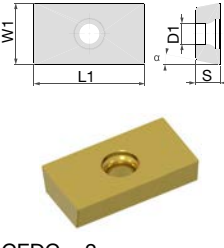

Schweißkantenbearbeitung, Fräswendeplatten
Sheet edge preparation, milling inserts

CEDC = Anzahl der Schneidkanten CEDC = Number of cutting edges	Artikelbezeichnung Item code	Schneidstoffsorte Cutting materials	Bestell-Nr. Ordering No.	Verfügbarkeit Availability	Abmessungen [mm] Dimensions [mm]								Ersatzteile Spare parts		
					L	L1	IC	S	D1	RE	W1	α			
 <p>CEDC = 4</p>	LCNX 201007	BCM40M	5221100	○	20	18	-	7	5,8	-	16	-	A02-50130 5090952		
 <p>CEDC = 4</p>	LOCX 3010	BCP37M	5221101	○	-	30	-	10	6,7	-	10	-	A02-60160 6401270		
 <p>CEDC = 2</p>	LPNX 360805	BCP37M	5221102	●	-	36	-	8	6,6	0,5	20	11	A02-60160 6401270		

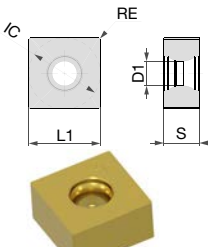
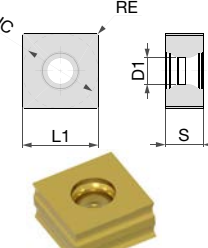
CEDC = Anzahl der Schneidkanten CEDC = Number of cutting edges	Artikelbezeichnung Item code	Schneidstoffsorte Cutting materials	Bestell-Nr. Ordering No.	Verfügbarkeit Availability	Abmessungen [mm] Dimensions [mm]							Ersatzteile Spare parts
					L	L1	IC	S	D1	RE	α	
 <p>CEDC = 8</p>	SNEX 150704	BCP37M	5221091	○	-	15,88	15,88	7,94	5,5	0,4	-	A02-50130 5090952
	SNNX 150704	BCP30E	5086724	●	-	15,88	15,88	7,94	5,5	0,4	-	
	SNNX 150704	BCP37M	5221093	●	-	15,88	15,88	7,94	5,5	0,4	-	
	SNEX 170704	BCP37M	5221094	○	-	17	17	7,94	6,4	0,4	-	A02-60160 6401270
	SNEX 190704	BCP37M	5221095	○	-	19	19	7,94	6,4	0,4	-	
	SNNX 190704	BCP30E	5084443	●	-	19	19	7,94	6,4	0,4	-	
	SNNX 190704	BCP37M	5221097	●	-	19	19	7,94	6,4	0,4	-	
	 <p>CEDC = 8</p>	SNNX 1507 FP	BCP40M	5136526	●	-	15,88	15,88	7,94	5,8	-	-
SNNX 1507 FP		BCP37M	5221099	●	-	15,88	15,88	7,94	5,8	-	-	
SNNX 1907 FP		BCP40M	5221268	●	-	18,2	19	7,94	5,8	0,4	-	
SNNX 1907 FP		BCP37M	5221267	●	-	18,2	19	7,94	5,8	0,4	-	

Bestellbeispiel Order example: 10 Stück 10 piece LCNX 201007 oder or 5221100

CEDC = Anzahl der Schneidkanten CEDC = Number of cutting edges	Artikelbezeichnung Item code	Schneidstoffsorte Cutting materials	Bestell-Nr. Ordering No.	Verfügbarkeit Availability	Abmessungen [mm] Dimensions [mm]							Ersatzteile Spare parts
					L	L1	IC	S	D1	RE	α	
 CEDC = 4	SPGW 190612	BCP37M	5221103	○	-	19,05	19,05	6,35	6,6	0,4	11°	A02-60160 6401270
	SPNW 190604	BCP37M	5221104	●	-	19,05	19,05	6,35	6,6	0,4	11°	
	SPNW 190604	BCP30E	5221105	○	-	19,05	18,93	6,35	6,6	0,4	11°	

CEDC = Anzahl der Schneidkanten CEDC = Number of cutting edges	Artikelbezeichnung Item code	Schneidstoffsorte Cutting materials	Bestell-Nr. Ordering No.	Verfügbarkeit Availability	Abmessungen [mm] Dimensions [mm]							Ersatzteile Spare parts
					L	L1	IC	S	D1	RE	α	
 CEDC = 6	TNNQ 3307	BCP37M	5221085	○	33	27,90	19,05	7,00	6,7	-	0°	A02-60160 6401270
 CEDC = 3	TPNX 2807	BCP37M	5221086	○	28,58	24,2	16,5	7,00	5,5	-	11°	A06-45120 6401291
	TPNX 3106	BCP37M	5221087	●	31,00	22,69	17,90	6,35	6,6	-	11°	A02-60160 6401270
	TPNX 3307	BCP37M	5221088	●	33,00	24,28	19,05	7,00	6,7	1,2	11°	
 CEDC = 3	TPNX 330716	BCP30E	5221089	○	33,00	27,45	19,05	7,00	6,6	1,6	11°	A02-60160 6401270
	TPNX 330716	BCP37M	5221090	○	33,00	27,45	19,05	7,00	6,6	1,6	11°	

Bestellbeispiel Order example: 10 Stück 10 piece SPGW 190612 oder or 5221103
Farbliche Abbildung der WSP müssen nicht dem Original entsprechen!
Colours of the original indexable inserts may deviate from the illustration!

- Verfügbar ab Lager Available from stock
- kurzfristig lieferbar available at short notice
- Auf Anfrage On request

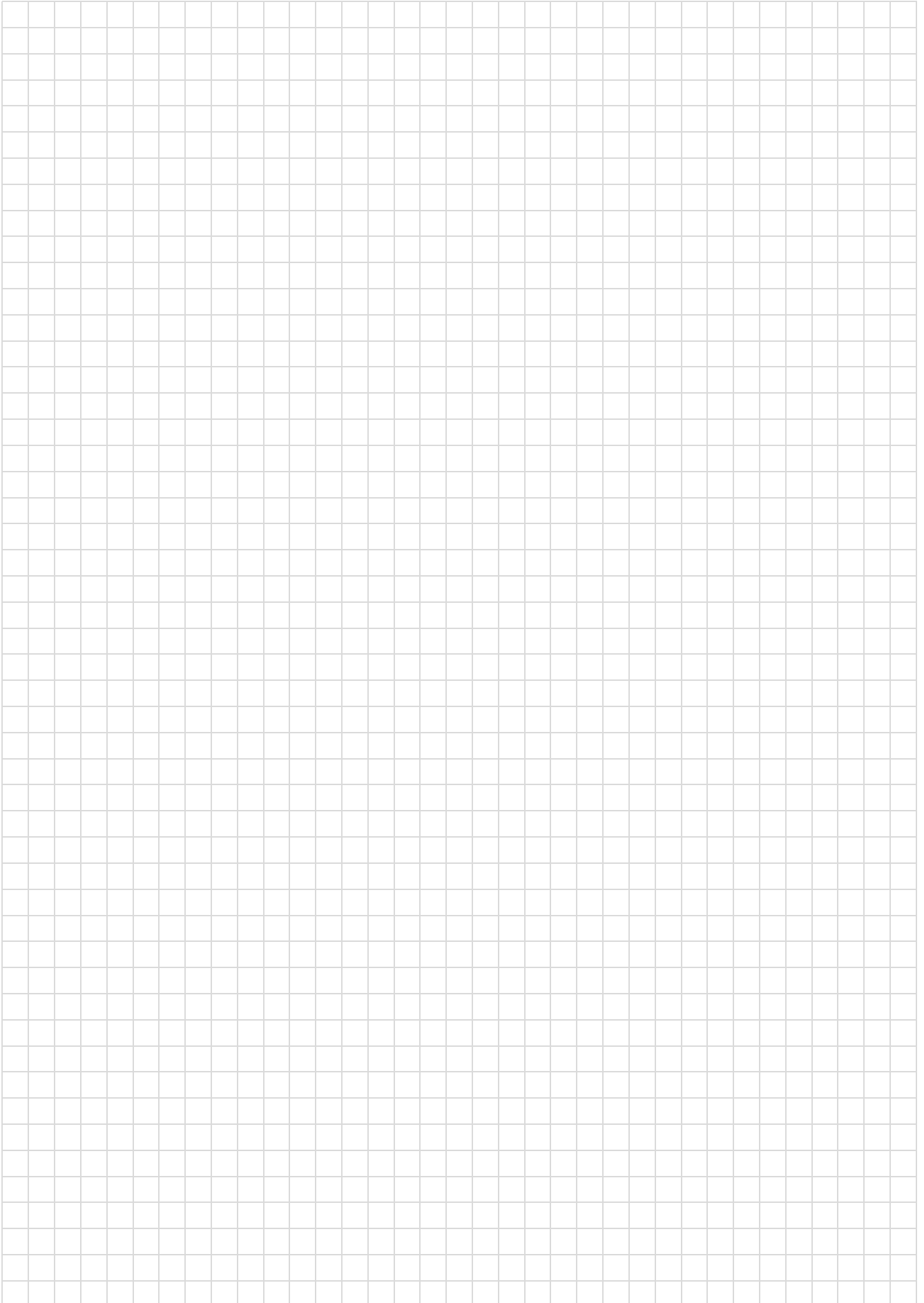

Schweißnahtbearbeitung
Weld seam scarfing

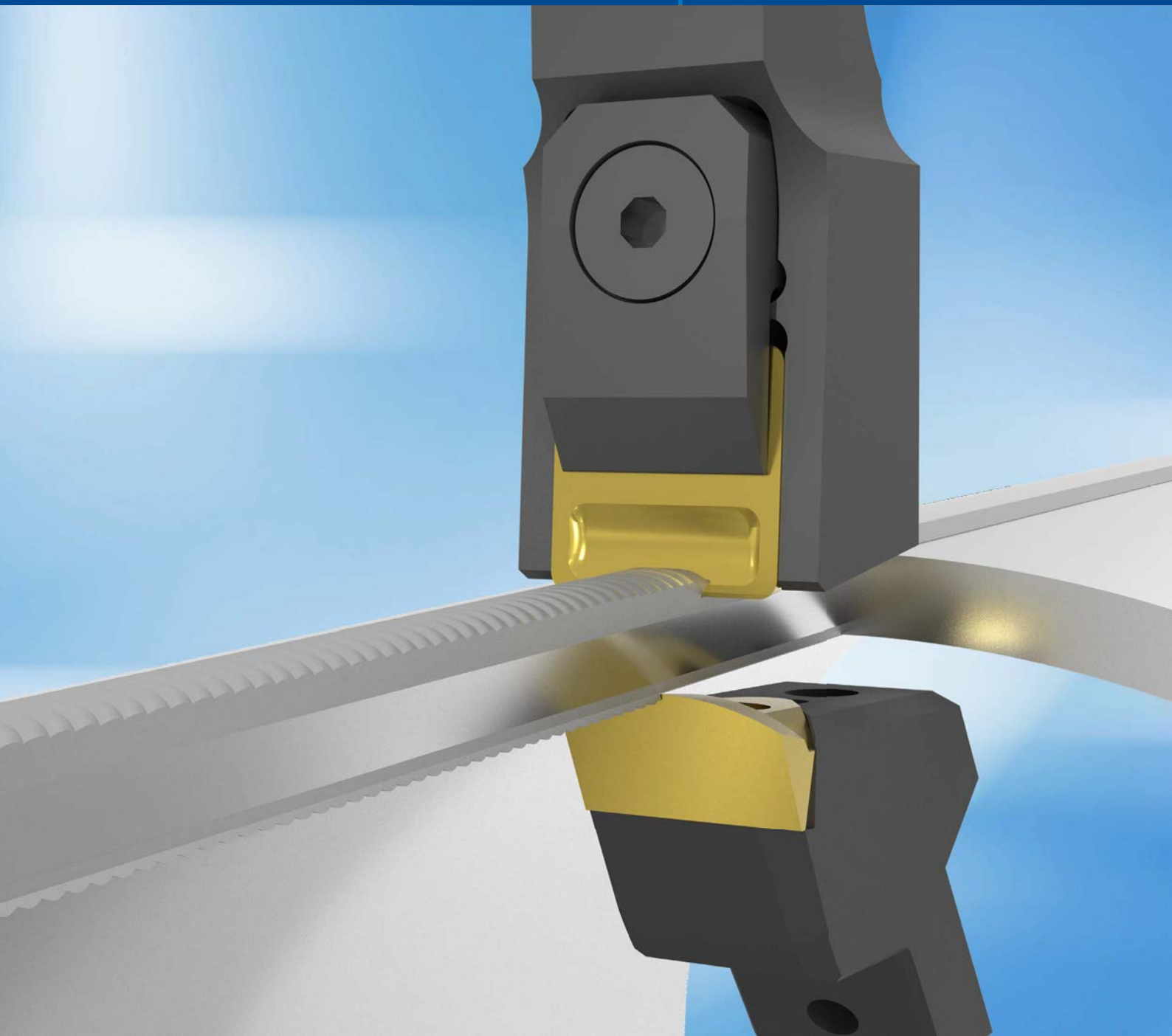

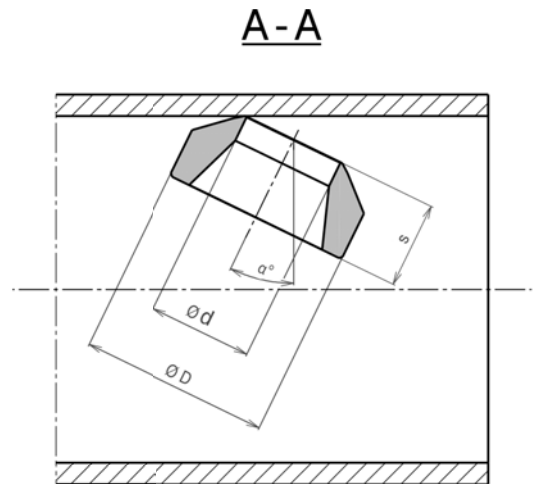
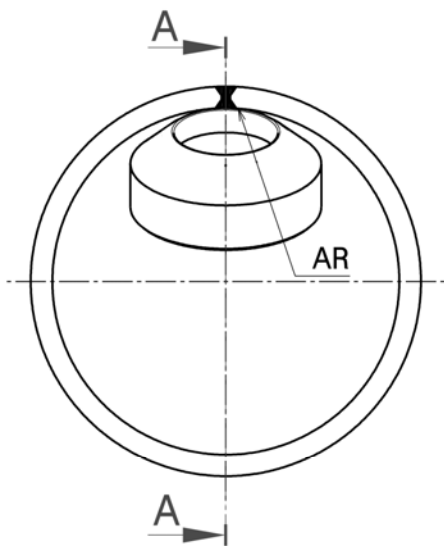

Innenentgraten mit Schneidringen

- effizient: mehrfach einsetzbar durch nachdrehbare Schneide
- präzise: enge Formtoleranzen am fertigen Rohr

Internal scarfing with scarfing rings

- efficient: multiple applicable due to returning cutting edge
- precise: small form tolerances on the finished tube

Hinweise zur Anwendung
Hints for application

Verbleibender Grat

- Arbeitsradius zu klein
- Schnitt zu wenig tief

Remaining burr

- Working radius too small
- to small depth of cut

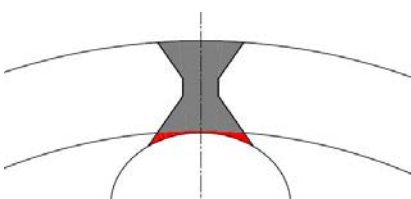

Verringerte Rohrwanddicke

- Arbeitsradius zu groß
- Schnitt zu tief

Reduced wall thickness

- Working radius to large
- to deep cut

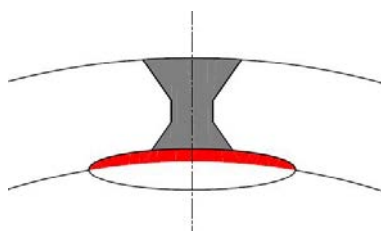

Richtig

- Arbeitsradius nahe Rohrinne Durchmesser
- Schweißnaht-Überstand entfernt
- Rohrwand gleichbleibend

Correct

- Working radius close to tube internal diameter
- weld seam burn fully removed
- constant wall thickness

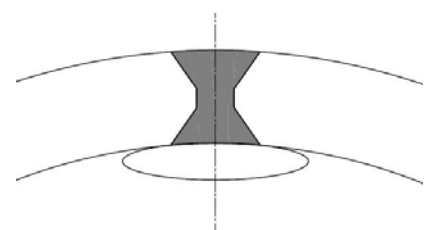

Ermittlung des AR (Arbeitsradius)
 eines Schneidringes

Determination of the AR (working
 radius) of a cutting ring

AR = D1 x f	
Anstellwinkel [α °] Approach angle [α °]	f
24	1,23
26	1,14
28	1,07
30	1,00

BSR.-AR..



Artikelbezeichnung Description	D1	Arbeitsradius AR für Working radius AR for		
		α 24°	α 26°	α 28°
BSR0 ARS4,5	4	5,0	4,5	4,0
BSR0 ARS5,5	5	6,0	5,5	5,5
BSR0 ARS6	5,5	7,0	6,0	6,0
BSR0 ARS6,5	6	7,5	6,5	6,5
BSR0 ARS7	6,5	8,0	7,0	7,0
BSR1 ARS7	6	7,5	7,0	6,5
BSR1 ARS8	7	8,5	8,0	7,5
BSR1 ARS9	8	10,0	9,0	8,5
BSR1 AR10	9	11,0	10,0	9,5
BSR2 AR9	8	10,0	9,0	8,5
BSR2 AR10	9	11,0	10,0	9,5
BSR2 AR11	10	12,5	11,0	10,5
BSR2 AR12	11	13,5	12,0	11,5
BSR2 AR14	12,5	15,5	14,0	13,5
BSR3 AR11	10	12,5	11,0	10,5
BSR3 AR12	11	13,5	12,0	11,5
BSR3 AR14	12	15,0	14,0	12,5
BSR3 AR17	15	18,5	17,0	16,0
BSR4 AR20	17	21,0	20,0	18,0
BSR4 AR21	18	22,0	21,0	19,0
BSR4 AR23	20	24,5	23,0	21,5
BSR5 AR25	22	27,0	25,0	23,5
BSR5 AR28	25	31,0	28,0	26,5
BSR6 AR34	30	37,0	34,0	32,0
BSR7 AR39	35	43,0	39,0	37,5
BSR8 AR46	40	49,0	46,0	42,5
BSR10 AR52	46	56,5	52,0	49,0

Innenentgraten mit Schneidringen
Internal scarfing with scarfing rings

BSR.-AR..

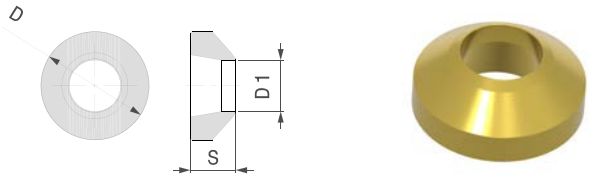

Artikelbezeichnung Description	Schneidstoffsorte Cutting materials	Bestell-Nr. Ordering No.	Verfügbarkeit Availability	Größe Size	Abmessungen [mm] Dimensions [mm]			Rohr IDmin Tube IDmin		Rohr IDmax Tube IDmax	
					D	D1	S	mm	INCH	mm	INCH
					BSR0 ARS4,5	BCP41S	5220445	○	0	8	4,0
BSR0 ARS5,5	5220446	○	0	8	5,0		4,0	15,5	0,61	18,5	0,73
BSR0 ARS6	5220449	○	0	10	5,5		4,5	17	0,67	20	0,79
BSR0 ARS6,5	5220450	○	0	10	6,0		5,0	17	0,67	20	0,79
BSR0 ARS7	5220452	○	0	10	6,5		4,5	17	0,67	22	0,87
BSR1 ARS7	5220469	○	1	13	6,0		5,0	20	0,79	22	0,87
BSR1 ARS8	5220470	○	1	13	7,0		5,0	22	0,87	24	0,95
BSR1 ARS9	5220472	○	1	13	8,0		5,0	24	0,95	26	1,02
BSR1 AR10	5220490	○	1	13	9,0		4,8	25	0,98	28	1,10
BSR2 AR9	5220491	○	2	19	8,0		8,5	24	0,95	26	1,02
BSR2 AR10	5220493	○	2	19	9,0		8,0	26	1,02	28	1,10
BSR2 AR11	5220566	○	2	19	10,0		8,0	28	1,10	30	1,18
BSR2 AR12	5220567	○	2	19	11,0		8,0	30	1,18	34	1,34
BSR2 AR14	5220569	○	2	19	12,5		7,5	32	1,26	41	1,61
BSR3 AR11	5220577	○	3	22	10,0		10,4	28	1,10	30	1,18
BSR3 AR12	5220579	○	3	22	11,0		10,2	30	1,18	34	1,34
BSR3 AR14	5220580	○	3	22	12,0		10,0	32	1,26	36	1,42
BSR3 AR17	5219196	○	3	22	15,0		10,0	36	1,42	41	1,61
BSR4 AR20	5220701	○	4	30	17,0		12,0	41	1,61	50	1,97
BSR4 AR21	5220705	○	4	30	18		12	44	1,73	54	2,13
BSR4 AR23	5220708	○	4	30	20,0		12,0	48	1,89	57	2,24
BSR5 AR25	5220709	○	5	35	22,0		12,0	70	2,77	84	3,31
BSR5 AR28	5220711	○	5	35	25,0		12,0	58	3,35	100	3,94
BSR6 AR34	5220718	○	6	45	30,0		15,0	100	3,94	130	5,12
BSR7 AR39	5220737	○	7	50	35,0		15,0	130	5,12	150	5,91
BSR8 AR46	5220741	○	8	55	40,0		18	150	5,91	160	6,3
BSR10 AR52	5220744	○	10	65	46,0		20	160	6,3	170	6,7

- Verfügbar ab Lager Available from stock
- ⦿ kurzfristig lieferbar available at short notice
- Auf Anfrage On request

Bestellbeispiel Order example: 10 Stück 10 piece BSR0 ARS4,5 oder or 5220445

Schweißnahtbearbeitung innen, Schneideinsätze
Weld seam scarfing internal, scarfing inserts



CEDC = Anzahl der Schneidkanten CEDC = Number of cutting edges	Artikel- bezeichnung Item code	Schneid- stoffsorte Cutting materials	Bestell-Nr. Ordering No.	Verfügbarkeit Availability	Abmessungen [mm] Dimensions [mm]							Ersatzteile Spare parts
					RS	L1	L	D1	S	RE	α	
 CEDC = 1	ISD8 R6,5	BCP15S	5133970	●	6,5	8	21,5	4,3	8	-	-	A02-40108 6401263
	ISD8 R8	BCP15S	5117549	●	8	8	21,5	4,3	8	-	-	
 CEDC = 1	ISD10 R8	BCP15S	5179157	●	8	10	21,5	4,3	8	-	-	A02-40108 6401263
	ISD10 R10	BCP15S	5178545	○	10	10	21,5	4,3	8	-	-	
 CEDC = 1	ISD12 R8	BCP15S	5146336	●	8	12	24	5,5	10,3			A07-40120 6401295
	ISD12 R10	BCP15S	5105752	●	10	12	24	5,5	10,3			
	ISD12 R12	BCP15S	5146337	○	12	12	24	5,5	10,3			
	ISD12 R14	BCP15S	5172745	●	14	12	24	5,5	10,3			
 CEDC = 1	ISD14 R12	BCP15S	5216707	●	12	14	26,1	6	14,1			A07-40120 6401295
	ISD14 R14	BCP15S	5179275	●	14	14	26,1	6	14,1	-	-	
	ISD14 R14	BCP25S	5179301	○	14	14	26,1	6	14,1	-	-	
	ISD14 R14	BCP35S	5179303	○	14	14	26,1	6	14,1	-	-	

Bestellbeispiel Order example: 10 Stück 10 piece ISD8 R6,5 oder or 5133970

Farbliche Abbildung der WSP müssen nicht dem Original entsprechen!
 Colours of the original indexable inserts may deviate from the illustration!

Schweißnahtbearbeitung innen, Schneideinsätze
Weld seam scarfing internal, scarfing inserts

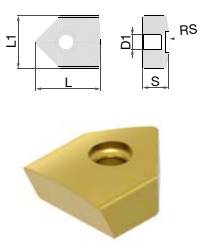
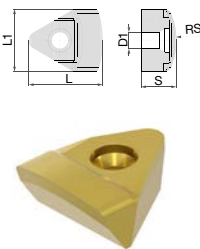
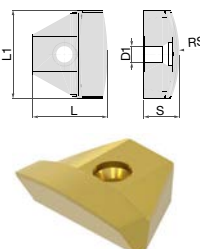
CEDC = Anzahl der Schneidkanten CEDC = Number of cutting edges	Artikel- bezeichnung Item code	Schneid- stoffsorte Cutting materials	Bestell-Nr. Ordering No.	Verfügbarkeit Availability	Abmessungen [mm] Dimensions [mm]							Ersatzteile Spare parts
					Rs	L1	L	D1	S	RE	α	
 <p>CEDC = 1</p>	ISD20 R25	BCP35S	5087694	●	25	19,85	24,4	5,5	10	-	-	D22032 5049762
	ISD20 R35	BCP35S	5176720	○	35	19,85	24,4	5,5	10	-	-	
	ISD20 R50	BCP35S	5176721	○	50	19,85	24,4	5,5	10	-	-	
	ISD20 R70	BCP35S	5176722	○	70	19,85	24,4	5,5	10	-	-	
 <p>CEDC = 1</p>	ISD25 R20	BCP35S	5058091	●	20	24,85	29,37	6,6	14	-	-	A02-60160 6401270
	ISD25 R25	BCP35S	5058094	●	25	24,85	29,37	6,6	14	-	-	
	ISD25 R30	BCP35S	5098533	●	30	24,85	29,37	6,6	14	-	-	
	ISD25 R35	BCP35S	5058095	●	35	24,85	29,37	6,6	14	-	-	
	ISD25 R40	BCP35S	5212216	○	40	24,85	29,37	6,6	14	-	-	
	ISD25 R50	BCP35S	5098420	●	50	24,85	29,37	6,6	14	-	-	
	ISD25 R70	BCP35S	5098421	●	70	24,85	29,37	6,6	14	-	-	
 <p>CEDC = 1</p>	ISD35 R30	BCP35S	5212223	○	30	35	29,5	6,6	14	-	-	A02-60160 6401270
	ISD35 R35	BCP35S	5093832	○	35	35	29,5	6,6	14	-	-	
	ISD35 R45	BCP35S	5212230	○	45	35	29,5	6,6	14	-	-	
	ISD35 R50	BCP35S	5093797	○	50	35	29,5	6,6	14	-	-	
	ISD35 R55	BCP35S	5212232	○	55	35	29,5	6,6	14	-	-	
	ISD35 R70	BCP35S	5093830	○	70	35	29,5	6,6	14	-	-	

- Verfügbar ab Lager Available from stock
- kurzfristig lieferbar available at short notice
- Auf Anfrage On request

Bestellbeispiel Order example: 10 Stück 10 piece ISD20 R25 oder or 5087694

Schweißnahtbearbeitung außen, Wendeschneidplatten
Weld seam scarfing external, scarfing inserts



CEDC = Anzahl der Schneidkanten CEDC = Number of cutting edges	Artikelbezeichnung Item Code	Schneidstoffsorte Cutting materials	Bestell-Nr. Ordering No.	Verfügbarkeit Availability	Abmessungen [mm] Dimensions [mm]					Ersatzteile Spare part
					AC	S	D1	RS	α	
<p>CEDC = 6</p>	ROMX 2404 R10	BCP39S	5220714	●	24,4	4,75	5,35	10	18°	DIN7991 6412644
	ROMX 2404 R13		5220715	●	24,4	4,75	5,35	13	18°	
	ROMX 2404 R16		5220745	●	24,4	4,75	5,35	16	18°	
	ROMX 2404 R21		5220805	●	24,4	4,75	5,35	21	18°	
	ROMX 2404 R27		5220806	●	24,4	4,75	5,35	27	18°	
	ROMX 2404 R38		5220807	●	24,4	4,75	5,35	38	18°	
	ROMX 2404 R47		5220808	●	24,4	4,75	5,35	47	18°	
	ROMX 2404 R60		5220809	●	24,4	4,75	5,35	60	18°	
	ROMX 2404 R73		5220810	●	24,4	4,75	5,35	73	18°	

Einsatzbereich der Wendeschneidplatte
Application area of the indexable insert

	Rohrdurchmesser Tube diameter			
	Min. Tube OD		Max. Tube OD	
	mm	inch	mm	inch
ROMX 2404 R10	10	0,393	unter 15,88	under 5/8
ROMX 2404 R13	13	0,512	15,88 - 22,23	5/8 - 7/8
ROMX 2404 R14	14	0,551	20 - 25	0,79 - 0,98
ROMX 2404 R15	15	0,590	23 - 28	0,91 - 1,1
ROMX 2404 R16	16	0,630	22,23 - 31,75	7/8 - 1 1/4
ROMX 2404 R17,5	17	0,669	22 - 35	0,87 - 1,38
ROMX 2404 R21	21	0,826	31,75 - 41,28	1 1/4 - 1 5/8
ROMX 2404 R27	27	1,063	41,28 - 50,80	1 5/8 - 2
ROMX 2404 R38	38	1,496	50,80 - 73,00	2 - 2 7/8
ROMX 2404 R47	47	1,850	73,00 - 92,08	2 7/8 - 3 5/8
ROMX 2404 R60	60	2,362	92,08 - 117,48	3 5/8 - 4 5/8
ROMX 2404 R73	73	2,874	117,48 - 142,88	4 5/8 - 5 5/8
ROMX 2404 R98	98	3,858	168,28 - 193,68	6 5/8 - 7 5/8

***)Kundenspezifische Radiusausführung auf Anfrage! Wir beraten Sie gerne!**
***)Customized designs on request! We will be happy to advise you!**

Bestellbeispiel Order example: 10 Stück 10 piece ROMX 2404 R10 oder or 5220714

Farbliche Abbildung der WSP müssen nicht dem Original entsprechen!
 Colours of the original indexable inserts may deviate from the illustration!

- Verfügbar ab Lager Available from stock
- kurzfristig lieferbar available at short notice
- Auf Anfrage On request

Schweißnahtbearbeitung außen, Wendeschneidplatten
Weld seam scarfing external, scarfing inserts

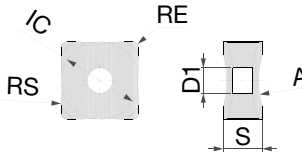
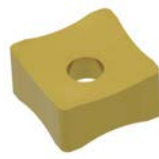
SNMX 15...									
CEDC = 8									
Artikelbezeichnung Item Code	Schneid stoffsorte Cutting materials	Bestell Nr. Ordering No.	Verfügbarkeit Availability	Abmessungen [mm] Dimensions [mm]					
				IC	S	RE	D1	A	RS
SNMX 150712 R07	BCP35S	5220875	○	15,87	7,94	1,20	5,16	7	22
SNMX 150712 R07	BCP39S	5220854	○	15,87	7,94	1,20	5,16	7	22
SNMX 150712 R09	BCP35S	5220876	○	15,87	7,94	1,20	5,16	9	22
SNMX 150712 R09	BCP39S	5220855	○	15,87	7,94	1,20	5,16	9	22
SNMX 150712 R10	BCP35S	5220877	○	15,87	7,94	1,20	5,16	10	22
SNMX 150712 R10	BCP39S	5220856	○	15,87	7,94	1,20	5,16	10	22
SNMX 150712 R13	BCP35S	5220878	○	15,87	7,94	1,20	5,16	13	22
SNMX 150712 R13	BCP39S	5220857	○	15,87	7,94	1,20	5,16	13	22
SNMX 150712 R15	BCP35S	5220879	○	15,87	7,94	1,20	5,16	15	22
SNMX 150712 R15	BCP39S	5220858	○	15,87	7,94	1,20	5,16	15	22
SNMX 150712 R18	BCP35S	5220880	○	15,87	7,94	1,20	5,16	18	22
SNMX 150712 R18	BCP39S	5220859	○	15,87	7,94	1,20	5,16	18	22
SNMX 150712 R20	BCP35S	5220881	○	15,87	7,94	1,20	5,16	20	22
SNMX 150712 R20	BCP39S	5220860	○	15,87	7,94	1,20	5,16	20	22
SNMX 150712 R22	BCP35S	5220882	○	15,87	7,94	1,20	5,16	22	22
SNMX 150712 R22	BCP39S	5220861	○	15,87	7,94	1,20	5,16	22	22
SNMX 150712 R25	BCP35S	5220883	○	15,87	7,94	1,20	5,16	25	22
SNMX 150712 R25	BCP39S	5220862	○	15,87	7,94	1,20	5,16	25	22
SNMX 150712 R27	BCP35S	5220884	○	15,87	7,94	1,20	5,16	27	22
SNMX 150712 R27	BCP39S	5220863	○	15,87	7,94	1,20	5,16	27	22
SNMX 150712 R30	BCP35S	5220885	○	15,87	7,94	1,20	5,16	30	22
SNMX 150712 R30	BCP39S	5220864	○	15,87	7,94	1,20	5,16	30	22
SNMX 150712 R35	BCP35S	5220886	○	15,87	7,94	1,20	5,16	35	22
SNMX 150712 R35	BCP39S	5220865	○	15,87	7,94	1,20	5,16	35	22
SNMX 150712 R40	BCP35S	5220887	○	15,87	7,94	1,20	5,16	40	22
SNMX 150712 R40	BCP39S	5220866	○	15,87	7,94	1,20	5,16	40	22
SNMX 150712 R42	BCP35S	5220888	○	15,87	7,94	1,20	5,16	42	22
SNMX 150712 R42	BCP39S	5220867	○	15,87	7,94	1,20	5,16	42	22
SNMX 150712 R45	BCP35S	5220889	○	15,87	7,94	1,20	5,16	45	22
SNMX 150712 R45	BCP39S	5220868	○	15,87	7,94	1,20	5,16	45	22
SNMX 150712 R50	BCP35S	5220890	○	15,87	7,94	1,20	5,16	50	22
SNMX 150712 R50	BCP39S	5220869	○	15,87	7,94	1,20	5,16	50	22
SNMX 150712 R55	BCP35S	5220891	○	15,87	7,94	1,20	5,16	55	22
SNMX 150712 R55	BCP39S	5220870	○	15,87	7,94	1,20	5,16	55	22
SNMX 150712 R60	BCP35S	5220892	○	15,87	7,94	1,20	5,16	60	22
SNMX 150712 R60	BCP39S	5220871	○	15,87	7,94	1,20	5,16	60	22
SNMX 150712 R65	BCP35S	5220893	○	15,87	7,94	1,20	5,16	65	22
SNMX 150712 R65	BCP39S	5220872	○	15,87	7,94	1,20	5,16	65	22
SNMX 150712 R70	BCP35S	5220894	○	15,87	7,94	1,20	5,16	70	22
SNMX 150712 R70	BCP39S	5220873	○	15,87	7,94	1,20	5,16	70	22
SNMX 150712 R75	BCP35S	5220895	○	15,87	7,94	1,20	5,16	75	22
SNMX 150712 R75	BCP39S	5220874	○	15,87	7,94	1,20	5,16	75	22

- Verfügbar ab Lager Available from stock
- ⦿ kurzfristig lieferbar available at short notice
- Auf Anfrage On request

Bestellbeispiel Order example: 10 Stück 10 piece SNMX-150712-R07 oder or 5220875

Einsatzbereich der Wendeschneidplatte
 Application area of the indexable insert

SNMX 15... 	Rohrdurchmesser Tube diameter			
	Min. Tube OD		Max. Tube OD	
	mm	inch	mm	inch
	SNMX 150712 R07	9,80	0,386	12,60
SNMX 150712 R09	12,60	0,496	15,88	0,625
SNMX 150712 R10	13,30	0,524	17,20	0,677
SNMX 150712 R13	15,88	0,625	22,23	0,875
SNMX 150712 R15	18,90	0,744	27,60	1,087
SNMX 150712 R18	25,20	0,992	33,12	1,304
SNMX 150712 R20	28,00	1,102	36,80	1,449
SNMX 150712 R22	30,90	1,213	39,60	1,560
SNMX 150712 R25	35,00	1,378	41,25	1,625
SNMX 150712 R27	41,28	1,625	50,80	2,000
SNMX 150712 R30	42,00	1,654	55,20	2,173
SNMX 150712 R35	49,00	1,929	64,40	2,535
SNMX 150712 R40	56,00	2,205	73,60	2,898
SNMX 150712 R42	59,00	2,320	77,50	3,05
SNMX 150712 R45	63,00	2,480	82,80	3,260
SNMX 150712 R50	75,00	2,953	92,08	3,625
SNMX 150712 R55	83,50	3,287	104,78	4,191
SNMX 150712 R60	92,08	3,625	117,48	4,625
SNMX 150712 R65	100,66	3,963	125,6	4,945
SNMX 150712 R70	109,24	4,300	136,2	5,362
SNMX 150712 R75	117,82	4,638	145,7	5,736

Farbliche Abbildung der WSP müssen nicht dem Original entsprechen!
 Colours of the original indexable inserts may deviate from the illustration!

Schweißnahtbearbeitung außen, Wendeschneidplatten
Weld seam scarfing external, scarfing inserts

SNMX 19... CEDC = 8									
Artikelbezeichnung Item Code	Schneid stoffsorte Cutting materials	Bestell Nr. Ordering No.	Verfügbarkeit Availability	Abmessungen [mm] Dimensions [mm]					
				IC	S	RE	D1	A	R
SNMX 190708 R00	BCP35S	5220926	○	19,05	7,94	0,8	7,93	0	35
SNMX 190708 R00	BCP39S	5220916	○	19,05	7,94	0,8	7,93	0	35
SNMX 190708 R10	BCP35S	5220927	○	19,05	7,94	0,8	7,93	10	35
SNMX 190708 R10	BCP39S	5220917	○	19,05	7,94	0,8	7,93	10	35
SNMX 190708 R12	BCP35S	5220928	○	19,05	7,94	0,8	7,93	12	35
SNMX 190708 R12	BCP39S	5220918	○	19,05	7,94	0,8	7,93	12	35
SNMX 190708 R15	BCP35S	5220929	○	19,05	7,94	0,8	7,93	15	35
SNMX 190708 R15	BCP39S	5220919	○	19,05	7,94	0,8	7,93	15	35
SNMX 190708 R20	BCP35S	5220930	○	19,05	7,94	0,8	7,93	20	35
SNMX 190708 R20	BCP39S	5220920	○	19,05	7,94	0,8	7,93	20	35
SNMX 190708 R25	BCP35S	5220931	○	19,05	7,94	0,8	7,93	25	35
SNMX 190708 R25	BCP39S	5220921	○	19,05	7,94	0,8	7,93	25	35
SNMX 190708 R35	BCP35S	5220932	○	19,05	7,94	0,8	7,93	35	35
SNMX 190708 R35	BCP39S	5220922	○	19,05	7,94	0,8	7,93	35	35
SNMX 190708 R45	BCP35S	5220933	○	19,05	7,94	0,8	7,93	45	35
SNMX 190708 R45	BCP39S	5220923	○	19,05	7,94	0,8	7,93	45	35
SNMX 190708 R55	BCP35S	5220934	○	19,05	7,94	0,8	7,93	55	35
SNMX 190708 R55	BCP39S	5220924	○	19,05	7,94	0,8	7,93	55	35
SNMX 190708 R60	BCP35S	5220935	○	19,05	7,94	0,8	7,93	60	35
SNMX 190708 R60	BCP39S	5220925	○	19,05	7,94	0,8	7,93	60	35

Einsatzbereich der Wendeschneidplatte
Application area of the indexable insert

	Rohrdurchmesser Tube diameter			
	Min. Tube OD		Max. Tube OD	
	mm	inch	mm	inch
SNMX 190708 R00	no radius used for larger tube sizes			
SNMX 190708 R10	14,00	0,551	18,90	0,744
SNMX 190708 R12	15,88	0,625	22,33	0,875
SNMX 190708 R15	18,90	0,744	27,60	1,087
SNMX 190708 R20	28,00	1,102	36,80	1,449
SNMX 190708 R25	35,00	1,378	41,28	1,625
SNMX 190708 R35	49,00	1,929	64,40	2,535
SNMX 190708 R45	63,00	2,480	82,80	3,260
SNMX 190708 R55	82,50	3,248	97,50	3,839
SNMX 190708 R60	92,08	3,625	117,48	4,625

- Verfügbar ab Lager Available from stock
- ⦿ kurzfristig lieferbar available at short notice
- Auf Anfrage On request

Bestellbeispiel Order example: 10 Stück 10 piece SNMX-190708-R00 oder or 5220926

Schweißnahtbearbeitung außen, Wendeschneidplatten
Weld seam scarfing external, scarfing inserts



SNMX 25...									
CEDC = 8									
Artikelbezeichnung Item Code	Schneid stoffsorte Cutting materials	Bestell Nr. Ordering No.	Verfügbarkeit Availability	Abmessungen [mm] Dimensions [mm]					
				IC	S	RE	D1	A	R
SNMX 251208 R00	BCP35S	5221189	o	25,40	12,70	0,8	9,12	0	48
SNMX 251208 R00	BCP39S	5221201	o	25,40	12,70	0,8	9,12	0	48
SNMX 251208 R25	BCP35S	5221190	o	25,40	12,70	0,8	9,12	25	48
SNMX 251208 R25	BCP39S	5221202	o	25,40	12,70	0,8	9,12	25	48
SNMX 251208 R35	BCP35S	5221191	o	25,40	12,70	0,8	9,12	35	48
SNMX 251208 R35	BCP39S	5221203	o	25,40	12,70	0,8	9,12	35	48
SNMX 251208 R50	BCP35S	5221192	o	25,40	12,70	0,8	9,12	50	48
SNMX 251208 R50	BCP39S	5221204	o	25,40	12,70	0,8	9,12	50	48
SNMX 251208 R65	BCP35S	5221193	o	25,40	12,70	0,8	9,12	65	48
SNMX 251208 R65	BCP39S	5221205	o	25,40	12,70	0,8	9,12	65	48
SNMX 251208 R80	BCP35S	5221194	o	25,40	12,70	0,8	9,12	80	48
SNMX 251208 R80	BCP39S	5221206	o	25,40	12,70	0,8	9,12	80	48
SNMX 251208 R90	BCP35S	5221195	o	25,40	12,70	0,8	9,12	90	48
SNMX 251208 R90	BCP39S	5221207	o	25,40	12,70	0,8	9,12	90	48
SNMX 251208 R100	BCP35S	5221196	o	25,40	12,70	0,8	9,12	100	48
SNMX 251208 R100	BCP39S	5221208	o	25,40	12,70	0,8	9,12	100	48
SNMX 251208 R120	BCP35S	5221197	o	25,40	12,70	0,8	9,12	120	48
SNMX 251208 R120	BCP39S	5221209	o	25,40	12,70	0,8	9,12	120	48
SNMX 251208 R150	BCP35S	5221198	o	25,40	12,70	0,8	9,12	150	48
SNMX 251208 R150	BCP39S	5221210	o	25,40	12,70	0,8	9,12	150	48
SNMX 251208 R200	BCP35S	5221199	o	25,40	12,70	0,8	9,12	200	48
SNMX 251208 R200	BCP39S	5221211	o	25,40	12,70	0,8	9,12	200	48
SNMX 251208 R250	BCP35S	5221200	o	25,40	12,70	0,8	9,12	250	48
SNMX 251208 R250	BCP39S	5221212	o	25,40	12,70	0,8	9,12	250	48

Einsatzbereich der Wendeschneidplatte
Application area of the indexable insert

SNMX 25... 	Rohrdurchmesser Tube diameter			
	Min. Tube OD		Max. Tube OD	
	mm	inch	mm	inch
SNMX 251208 R00	no radius used for larger tube sizes			
SNMX 251208 R25	35,00	1,378	41,25	1,625
SNMX 251208 R35	49,00	1,929	64,4	2,535
SNMX 251208 R50	75,00	2,953	92,08	3,625
SNMX 251208 R65	97,50	3,839	120,00	4,724
SNMX 251208 R80	120,0	4,724	147,20	3,795
SNMX 251208 R90	135,0	5,315	171,00	6,732
SNMX 251208 R100	150,0	5,905	190,00	7,480
SNMX 251208 R120	180,0	7,078	228,00	8,976
SNMX 251208 R150	225,0	8,858	285,00	11,220
SNMX 251208 R200	300,0	11,811	380,00	14,961
SNMX 251208 R250	375,0	14,764	475,00	18,700

Bestellbeispiel Order example: 10 Stück 10 piece SNMX 251208 R00 oder or 5221189

Farbliche Abbildung der WSP müssen nicht dem Original entsprechen!
 Colours of the original indexable inserts may deviate from the illustration!

Schweißnahtbearbeitung außen, Wendeschneidplatten
Weld seam scarfing external, scarfing inserts

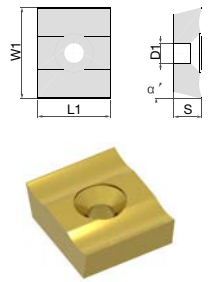
CEDC = Anzahl der Schneidkanten CEDC = Number of cutting edges	Artikelbezeichnung Item code	Schneidstoffsorte Cutting materials	Bestell-Nr. Ordering No.	Verfügbarkeit Availability	Abmessungen [mm] Dimensions [mm]							Ersatzteile Spare parts		
					L1	W1	S	RE	D1	A	α			
 <p>CEDC= 2</p>	LOXT 3912-MP	BCP35S	5219468	○	39	31	12	-	8,5	-	14°	DIN7991 6412660		

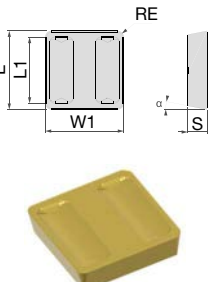
CEDC = Anzahl der Schneidkanten CEDC = Number of cutting edges	Artikelbezeichnung Item code	Schneidstoffsorte Cutting materials	Bestell-Nr. Ordering No.	Verfügbarkeit Availability	Abmessungen [mm] Dimensions [mm]							
					L1	W1	S	RE	D1	A	α	
 <p>CEDC= 2</p>	SPUX 250620-MP	BCP35S	5221213	○	25,4	21	25,4	6,35	2	11°	14°	
	SPUX 250620-MP	BWP40S	5220896	○	25,4	21	25,4	6,35	2	11°	14°	

- Verfügbar ab Lager Available from stock
- ⦿ kurzfristig lieferbar available at short notice
- Auf Anfrage On request

Bestellbeispiel Order example: 10 Stück 10 piece LOXT 3912-MP oder or 5219468

Schweißnahtbearbeitung außen, Wendeschneidplatten
Weld seam scarfing external, scarfing inserts



SDUW 25...				Abmessungen [mm] Dimensions [mm]							Ersatzteile Spare parts
Artikelbezeichnung Item Code	Schneidstoffsorte Cutting materials	Bestell Nr. Ordering No.	Verfügbarkeit Availability	L	IC	S	RE	D1	RS	α	
											A02 50140 9104781
SDUW 250920 R00	BCP35S	5220954	o	25,4	25,4	9,00	2,0	6	0	15°	
SDUW 250920 R20		5220955	o	25,4	25,4	9,00	2,0	6	20	15°	
SDUW 250920 R25		5220956	o	25,4	25,4	9,00	2,0	6	25	15°	
SDUW 250920 R35		5220957	o	25,4	25,4	9,00	2,0	6	35	15°	
SDUW 250920 R40		5220958	o	25,4	25,4	9,00	2,0	6	40	15°	
SDUW 250920 R45		5220959	o	25,4	25,4	9,00	2,0	6	45	15°	
SDUW 250920 R50		5220960	o	25,4	25,4	9,00	2,0	6	50	15°	
SDUW 250920 R55		5220961	o	25,4	25,4	9,00	2,0	6	55	15°	
SDUW 250920 R60		5220962	o	25,4	25,4	9,00	2,0	6	60	15°	
SDUW 250920 R65		5220963	o	25,4	25,4	9,00	2,0	6	65	15°	
SDUW 250920 R70		5220964	o	25,4	25,4	9,00	2,0	6	70	15°	
SDUW 250920 R75		5220965	o	25,4	25,4	9,00	2,0	6	75	15°	
SDUW 250920 R85		5220966	o	25,4	25,4	9,00	2,0	6	85	15°	
SDUW 250920 R100		5220967	o	25,4	25,4	9,00	2,0	6	100	15°	
SDUW 250920 R120		5220968	o	25,4	25,4	9,00	2,0	6	120	15°	
SDUW 250920 R160		5220969	o	25,4	25,4	9,00	2,0	6	160	15°	
SDUW 250920 R200		5220970	o	25,4	25,4	9,00	2,0	6	200	15°	
SDUW 250920 R250	5220971	o	25,4	25,4	9,00	2,0	6	250	15°		

Einsatzbereich der Wendeschneidplatte
Application area of the indexable insert

SDUW 25.. 	Rohrdurchmesser Tube diameter			
	Min. Tube OD		Max. Tube OD	
	mm	inch	mm	inch
SDUW 250920 R00				
SDUW 250920 R20	28,0	1,102	36,80	1,449
SDUW 250920 R25	35,0	1,378	41,28	1,625
SDUW 250920 R35	49,0	1,929	64,40	2,535
SDUW 250920 R40	56,0	2,205	73,60	2,898
SDUW 250920 R45	63,0	2,480	82,80	3,260
SDUW 250920 R50	75,0	2,953	92,08	3,625
SDUW 250920 R55	82,5	3,248	97,50	3,839
SDUW 250920 R60	92,08	3,625	117,48	4,625
SDUW 250920 R65	97,5	3,839	120,0	4,724
SDUW 250920 R70	109,0	4,134	128,8	5,071
SDUW 250920 R75	112,5	4,429	142,5	5,610
SDUW 250920 R85	127,5	5,020	161,5	6,358
SDUW 250920 R100	150,0	5,905	190,0	7,480
SDUW 250920 R120	180,0	7,087	228,0	8,976
SDUW 250920 R160	240,0	9,450	304,0	11,968
SDUW 250920 R200	300,0	11,811	380,0	14,961
SDUW 250920 R250	375,0	14,764	475,0	18,700

Bestellbeispiel Order example: 10 Stück 10 piece SDUW 250920 R00 oder or 5220954

Farbliche Abbildung der WSP müssen nicht dem Original entsprechen!
 Colours of the original indexable inserts may deviate from the illustration!

Schweißnahtbearbeitung außen, Wendeschneidplatten
Weld seam scarfing external, scarfing inserts

SDMX 25...								
CEDC = 4								
Artikelbezeichnung Item Code	Schneid stoffsorte Cutting materials	Bestell Nr. Ordering No.	Verfügbarkeit Availability	Abmessungen [mm] Dimensions [mm]				
				IC	S	RE	RS	α
SDMX 250616 R80	BCP25S	5221078	○	25,4	6,35	1,6	80	15°
SDMX 250616 R105		5221079	○	25,4	6,35	1,6	105	15°
SDMX 250616 R120		5221080	○	25,4	6,35	1,6	120	15°
SDMX 250616 R145		5221081	○	25,4	6,35	1,6	145	15°
SDMX 250616 R180		5221082	○	25,4	6,35	1,6	180	15°
SDMX 250616 R300		5221083	○	25,4	6,35	1,6	300	15°
SDMX 250616 R550		5221084	○	25,4	6,35	1,6	550	15°

Einsatzbereich der Wendeschneidplatte
Application area of the indexable insert

SDMX 25... 	Rohrdurchmesser Tube diameter			
	Min. Tube OD		Max. Tube OD	
	mm	inch	mm	inch
	SDMX 250616 R105	157,5	6,200	199,5
SDMX 250616 R120	180,0	7,087	228,0	8,976
SDMX 250616 R145	217,5	8,563	275,5	10,846
SDMX 250616 R180	270,0	10,630	342,0	13,465
SDMX 250616 R300	450,0	17,717	570,0	22,441
SDMX 250616 R550	825,0	32,480	1045,0	41,142

Bestellbeispiel Order example: 10 Stück 10 piece SDMX 250616 R80 oder or 5221078

- Verfügbar ab Lager Available from stock
- kurzfristig lieferbar available at short notice
- Auf Anfrage On request

SDUN 19...								
CEDC = 4								
Artikelbezeichnung Item Code	Schneidstoffsorte Cutting materials	Bestell Nr. Ordering No.	Verfügbarkeit Availability	Abmessungen [mm] Dimensions [mm]				
				IC	S	RE	RS	α
SDUN 190412 R0	BCP35S	5220983	o	19,05	4,76	1,2	0	15°
SDUN 190412 R15		5220984	o	19,05	4,76	1,2	15	15°
SDUN 190412 R19		5220985	o	19,05	4,76	1,2	19	15°
SDUN 190412 R20		5220986	o	19,05	4,76	1,2	20	15°
SDUN 190412 R25		5220987	o	19,05	4,76	1,2	25	15°
SDUN 190412 R32		5220988	o	19,05	4,76	1,2	32	15°
SDUN 190412 R39		5219633	o	19,05	4,76	1,2	39	15°
SDUN 190412 R45		5219635	o	19,05	4,76	1,2	45	15°
SDUN 190412 R48		5220991	o	19,05	4,76	1,2	48	15°
SDUN 190412 R64		5220992	o	19,05	4,76	1,2	64	15°
SDUN 190412 R80		5220993	o	19,05	4,76	1,2	80	15°

Einsatzbereich der Wendeschneidplatte
Application area of the indexable insert

SDUN 19... 	Rohrdurchmesser Tube diameter			
	Min. Tube OD		Max. Tube OD	
	mm	inch	mm	inch
SDUN 190412 R0	für große Durchmesser/used on large diameter			
SDUN 190412 R15	18	0,708	27	1,063
SDUN 190412 R19	27	1,063	36	1,417
SDUN 190412 R20	30	1,181	38	1,496
SDUN 190412 R25	35	1,378	47	1,850
SDUN 190412 R32	45	1,771	58	2,283
SDUN 190412 R39	58	2,283	70	2,756
SDUN 190412 R45	70	2,756	80	3,150
SDUN 190412 R48	75	2,953	93	3,625
SDUN 190412 R64	97	3,839	120	4,724
SDUN 190412 R80	112	4,429	142	5,610

Bestellbeispiel Order example: 10 Stück 10 piece SDUN 190412 R0 oder or 5220983

Farbliche Abbildung der WSP müssen nicht dem Original entsprechen!
Colours of the original indexable inserts may deviate from the illustration!

Schweißnahtbearbeitung außen, Wendeschneidplatten
Weld seam scarfing external, scarfing inserts

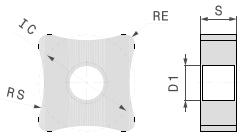
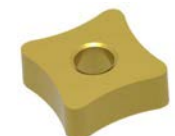
SNMA 25...								
CEDC = 8								
Artikelbezeichnung Item Code	Schneid stoffsorte Cutting materials	Bestell Nr. Ordering No.	Verfügbarkeit Availability	Abmessungen [mm] Dimensions [mm]				
				IC	S	RE	D1	RS
SNMA 250924 R25	BCD155	5221214	○	25,40	9,52	2,4	9,12	15
SNMA 250924 R30		5221215	○	25,40	9,52	2,4	9,12	30
SNMA 250924 R35		5221216	○	25,40	9,52	2,4	9,12	35
SNMA 250924 R40		5221217	○	25,40	9,52	2,4	9,12	40
SNMA 250924 R50		5221218	○	25,40	9,52	2,4	9,12	50
SNMA 250924 R60		5221219	○	25,40	9,52	2,4	9,12	60
SNMA 250924 R70		5221220	○	25,40	9,52	2,4	9,12	70
SNMA 250924 R80		5221221	○	25,40	9,52	2,4	9,12	80
SNMA 250924 R100		5221222	○	25,40	9,52	2,4	9,12	100
SNMA 250924 R150		5221223	○	25,40	9,52	2,4	9,12	150
SNMA 250924 R200		5221224	○	25,40	9,52	2,4	9,12	200

Einsatzbereich der Wendeschneidplatte
Application area of the indexable insert

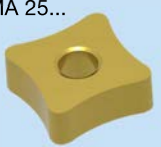
	Rohrdurchmesser Tube diameter			
	Min. Tube OD		Max. Tube OD	
	mm	inch	mm	inch
	SNMA 250924 R25	35,00	1,378	41,28
SNMA 250924 R30	42,00	1,654	55,20	2,173
SNMA 250924 R35	49,00	1,929	64,40	2,535
SNMA 250924 R40	56,00	2,205	73,60	2,898
SNMA 250924 R50	75,00	2,953	92,08	3,625
SNMA 250924 R60	92,08	3,625	117,48	4,625
SNMA 250924 R70	105,0	4,134	128,80	5,071
SNMA 250924 R80	120,0	4,724	147,20	5,795
SNMA 250924 R100	150,0	5,905	190,00	7,480
SNMA 250924 R150	225,0	8,858	285,00	11,220
SNMA 250924 R200	300,0	11,811	380,00	14,961

- Verfügbar ab Lager Available from stock
- kurzfristig lieferbar available at short notice
- Auf Anfrage On request

Bestellbeispiel Order example: 10 Stück 10 piece SNMA 250924 R25 oder or 5221214

Schweißnahtbearbeitung außen, Wendeschneidplatten
Weld seam scarfing external, scarfing inserts



Artikelbezeichnung Item Code		Schneidstoffsorte Cutting materials	Bestell Nr. Ordering No.	Verfügbarkeit Availability	Abmessungen [mm] Dimensions [mm]				
					IC	S	RE	D1	RS
SNMG...		BCP35S							
CEDC = 4									
SNMG 150708 R13			5219204	○	15,87	7,94	0,8	5,16	13
SNMG 150708 R22			5219477	○	15,87	7,94	0,8	5,16	22
SNMG 150708 R27			5219530	○	15,87	7,94	0,8	5,16	27
SNMG 150708 R35			5219536	○	15,87	7,94	0,8	5,16	35
SNMG 150708 R40			5219595	○	15,87	7,94	0,8	5,16	40
				○					
SNMG 190708 R12			5221029	○	19,05	7,94	0,8	8,00	12
SNMG 190708 R15			5221030	○	19,05	7,94	0,8	8,00	15
SNMG 190708 R40			5221034	○	19,05	7,94	0,8	8,00	42
SNMG 190708 R65			5221037	○	19,05	7,94	0,8	8,00	65
				○					
SNMG 251208 R35			5221040	○	25,40	12,7	0,8	9,12	35
SNMG 251208 R42			5221041	○	25,40	12,7	0,8	9,12	42
SNMG 251208 R55			5221042	○	25,40	12,7	0,8	9,12	55
SNMG 251208 R85			5221043	○	25,40	12,7	0,8	9,12	85
				○					

Einsatzbereich der Wendeschneidplatte
Application area of the indexable insert

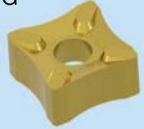
SNMG 	Rohrdurchmesser Tube diameter			
	Min. Tube OD		Max. Tube OD	
	mm	inch	mm	inch
SNMG 150708 R13	15,88	0,625	22,23	0,875
SNMG 150708 R22	30,80	1,213	39,00	1,560
SNMG 150708 R27	41,28	1,625	50,80	2,000
SNMG 150708 R35	49,00	1,929	64,40	2,535
SNMG 150708 R40	56,00	2,205	73,60	2,898
SNMG 190708 R12	15,88	0,625	22,23	0,875
SNMG 190708 R15	18,90	0,744	27,60	1,078
SNMG 190708 R40	56,0	2,205	73,60	2,898
SNMG 190708 R42	59,0	2,320	77,5	3,05
SNMG 190708 R65	100,66	3,963	125,60	4,945
SNMG 251108 R105	157,5	6,20	199,5	7,854
SNMG 251208 R35	49,0	1,929	64,4	2,535
SNMG 251208 R42	59,0	2,320	77,5	3,05
SNMG 251208 R55	82,5	3,248	97,5	3,839
SNMG 251208 R85	127,5	5,020	161,5	6,358

***)Kundenspezifische Radiusausführung auf Anfrage! Wir beraten Sie gerne!**
***)Customized designs on request! We will be happy to advise you!**

Bestellbeispiel Order example: 10 Stück 10 piece SNMG 150708 R13 oder or 5219204

Farbliche Abbildung der WSP müssen nicht dem Original entsprechen!
 Colours of the original indexable inserts may deviate from the illustration!

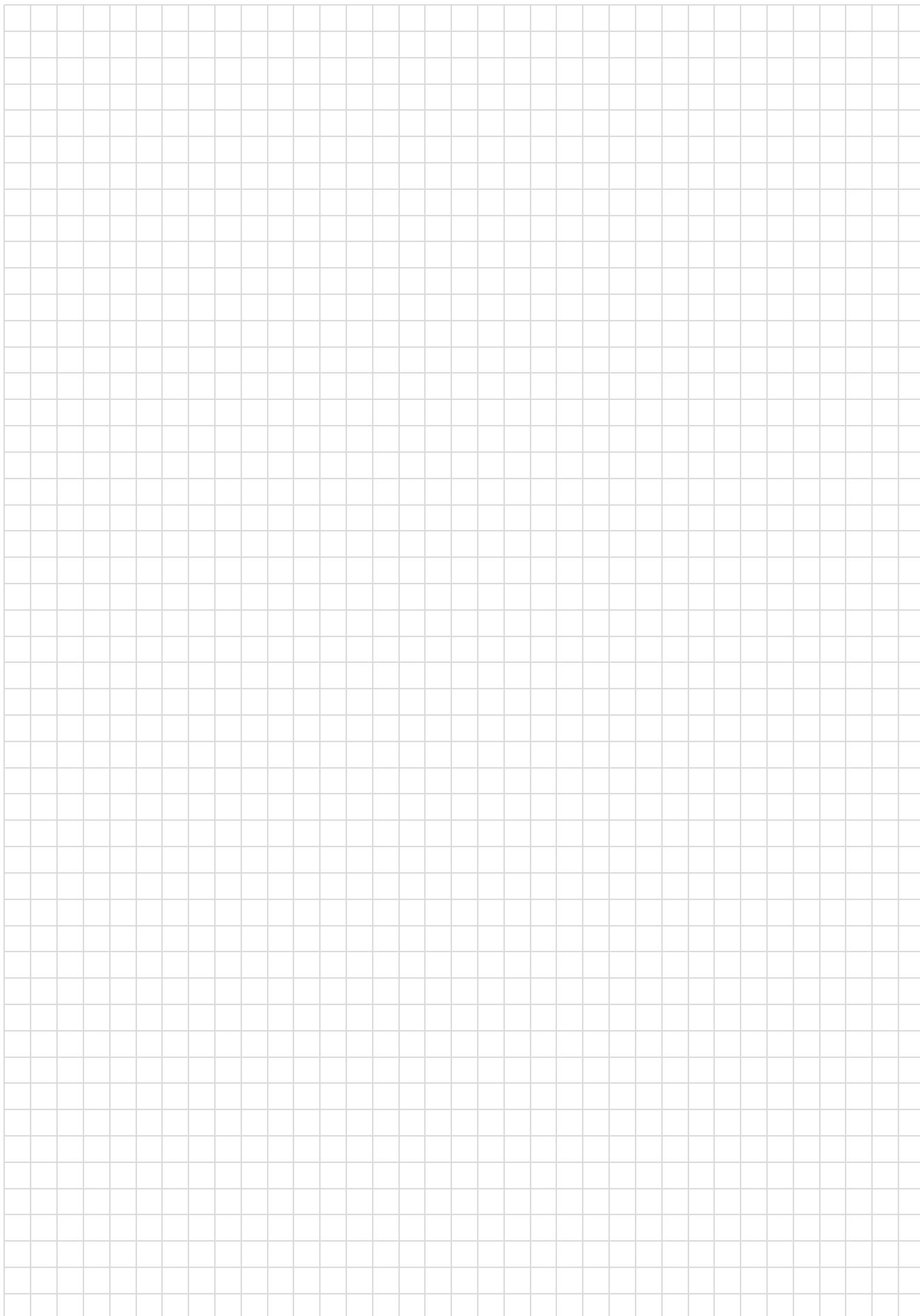

Rohrendenbearbeitung
Pipe end beveling

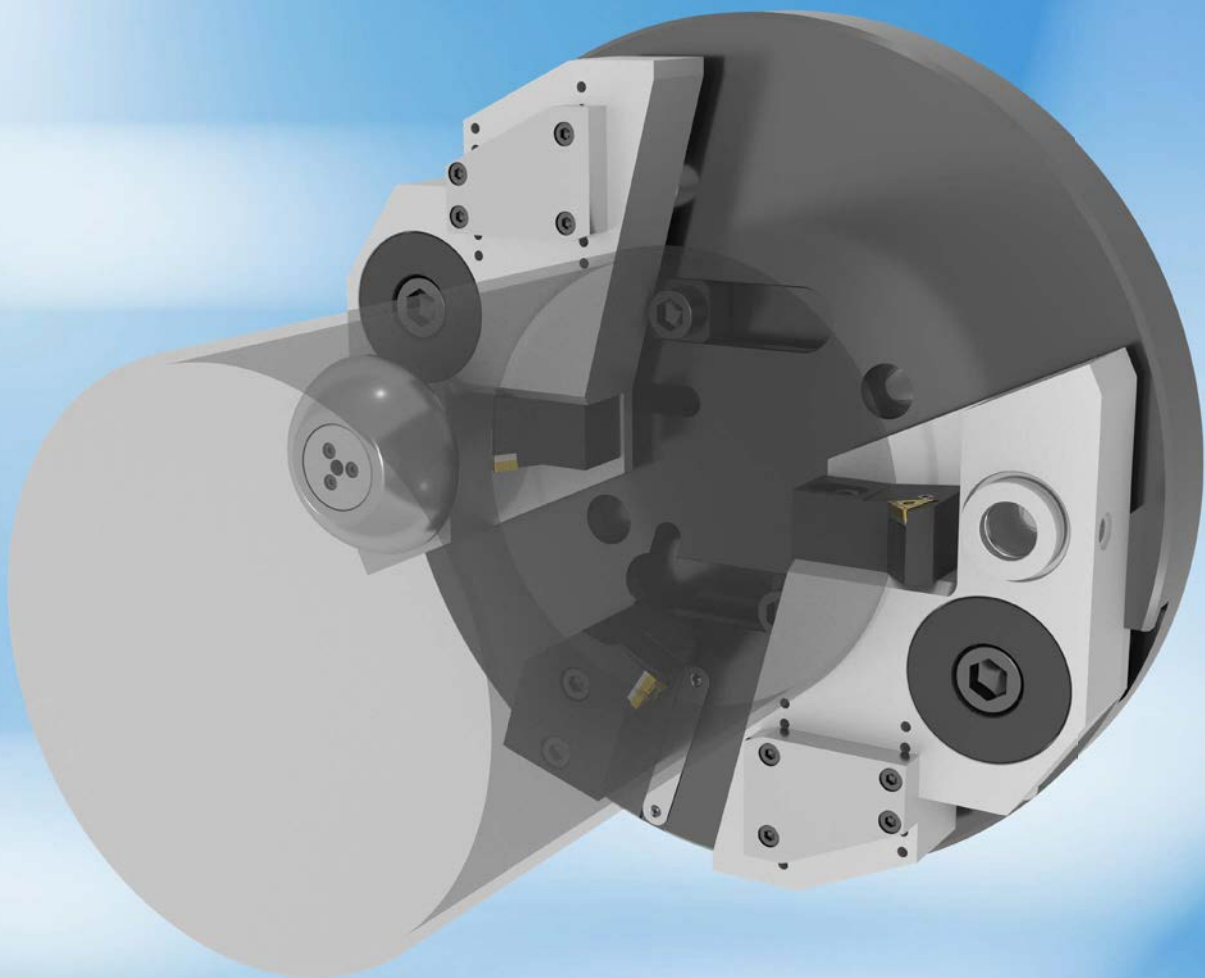

Wendeschneidplatten zur Rohrendenbearbeitung

Indexable inserts for pipe end beveling

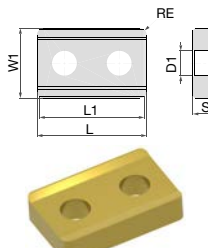
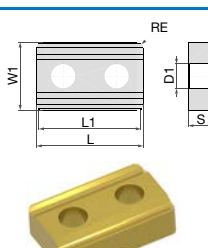
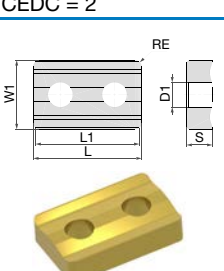
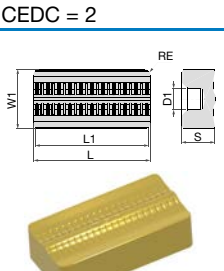
CEDC = Anzahl der Schneidkanten CEDC = Number of cutting edges	Artikelbezeichnung Item code	Schneidstoffsorte Cutting materials	Bestell-Nr. Ordering No.	Verfügbarkeit Availability	Abmessungen [mm] Dimensions [mm]					
					L	L1	W1	S	D1	RE
 <p>CEDC = 2</p>	LNUX 501224-OP	BCP25B	5221050	○	50	45,2	25,4	12,7	9,2	2,4
	LNUX 501224-OM	BCM25B	5221051	○	50	45,2	25,4	12,7	9,2	2,4
 <p>CEDC = 2</p>	LNUX 400924-MP	BCP25B	5221046	●	40	34,2	25,4	9,50	9,2	2,4
	LNUX 501224-MP	BCP25B	5221052	●	50	45,2	25,4	12,7	9,2	2,4
	LNUX 601224-MP	BCP25B	5221058	●	60	56,2	25,4	12,7	9,2	2,4
	LNUX 701224-MP	BCP25B	5221062	○	70	66,2	25,4	12,7	9,2	2,4
	LNUX 400924-MM	BCM25B	5221047	○	40	34,2	25,4	9,50	9,2	2,4
	LNUX 501224-MM	BCM25B	5221053	○	50	45,2	25,4	12,7	9,2	2,4
	LNUX 601224-MM	BCM25B	5221059	○	60	56,2	25,4	12,7	9,2	2,4
	LNUX 701224-MM	BCM25B	5221063	○	70	66,2	25,4	12,7	9,2	2,4
 <p>CEDC = 2</p>	LNUX 501224-LP	BCP25B	5221054	○	50	45,2	25,4	12,7	9,2	2,4
	LNUX 601224-LP	BCP25B	5221060	○	60	56,2	25,4	12,7	9,2	2,4
	LNUX 701224-LP	BCP25B	5221064	○	70	66,2	25,4	12,7	9,2	2,4
	LNUX 501224-LM	BCM25B	5221055	○	50	45,2	25,4	12,7	9,2	2,4
	LNUX 601224-LM	BCM25B	5221061	○	60	56,2	25,4	12,7	9,2	2,4
	LNUX 701224-LM	BCM25B	5221065	○	70	66,2	25,4	12,7	9,2	2,4
 <p>CEDC = 2</p>	LNUX 501224-TEP	BCP25B	5221056	○	50	45,2	25,4	12,7	9,2	2,4
	LNUX 701224-TEP	BCP25B	5221066	○	70	66,2	25,4	12,7	9,2	2,4
	LNUX 501224-TEM	BCM25B	5221057	○	50	45,2	25,4	12,7	9,2	2,4
	LNUX 701224-TEM	BCM25B	5221067	○	70	66,2	25,4	12,7	9,2	2,4

Bestellbeispiel Order example: 10 Stück 10 piece LNUX 501224-OP oder or 5221050
 Farbliche Abbildung der WSP müssen nicht dem Original entsprechen!
 Colours of the original indexable inserts may deviate from the illustration!

- Verfügbar ab Lager Available from stock
- kurzfristig lieferbar available at short notice
- Auf Anfrage On request

Wendeschneidplatten zur Rohrendenbearbeitung
Indexable inserts for pipe end beveling

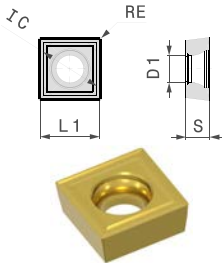
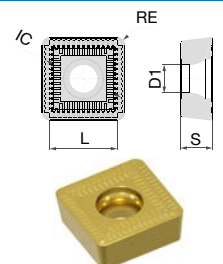
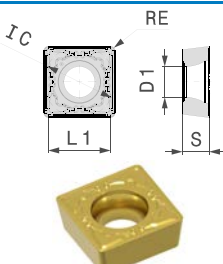
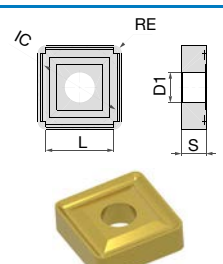

CEDC = Anzahl der Schneidkanten CEDC = Number of cutting edges	Artikelbezeichnung Item code	Schneidstoffsorte Cutting materials	Bestell-Nr. Ordering No.	Verfügbarkeit Availability	Abmessungen [mm] Dimensions [mm]					Ersatzteile Spare parts	
					IC	L1	S	D1	RE		
 <p>CEDC = 4</p>	SCMT 120404 FP	BCP25B	5221068	●	12,7	12,3	4,7	5,5	0,4	A02-50130 5090952	
 <p>CEDC = 4</p>	SCMT 250924-TEP	BCP25B	5221070	○	25,4	23	9,50	8,6	2,4	A02-80250 6401272	
 <p>CEDC = 4</p>	SCMT 120408-MP	BCP25B	5221069	●	12,7	11,9	4,70	5,5	0,8	A02-30130 5090952	
 <p>CEDC = 4</p>	SNMM 250724-LP	BCP25B	5221071	●	25,4	23	7,40	9,2	2,4	A02-80250 6401272	

Bestellbeispiel Order example: 10 Stück 10 piece SCMT 120404-FP oder or 5221068

Wendeschneidplatten zur Rohrendenbearbeitung
Indexable inserts for pipe end beveling

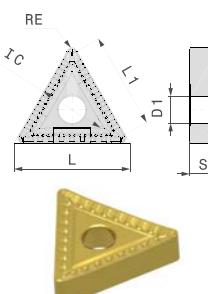
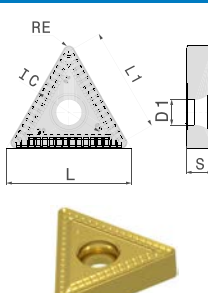
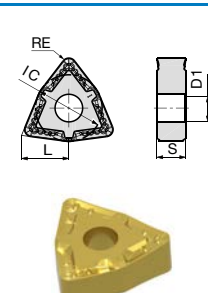
CEDC = Anzahl der Schneidkanten CEDC = Number of cutting edges	Artikel- bezeichnung Item code	Schneid- stoffsorte Cutting materials	Bestell-Nr. Ordering No.	Verfügbarkeit Availability	Abmessungen [mm] Dimensions [mm]						Ersatzteile Spare parts	
					IC	L	L1	S	D1	RE		
 <p>CEDC = 3</p>	TNMM 270612-TEP	BCP25B	5221076	○	15,87	27,5	22,7	6,35	6,35	1,2		
 <p>CEDC = 3</p>	TNMT 440920-TEM	BCM25B	5221077	●	25,4	44	37	9,52	9,00	2	A02-80250 6401272	
 <p>CEDC = 6</p>	WNMG 130924-MP	BCP25B	5221072	○	22	-	13	9,50	9,12	2,4	A02-80250 6401272	
	WNMG 130924-LP	BCP25B	5221073	○	22	-	13	9,50	9,12	2,4		
	WNMG 130924-MM	BCM25B	5221074	○	22	-	13	9,50	9,12	2,4		
	WNMG 130924-LM	BCM25B	5221075	○	22	-	13	9,50	9,12	2,4		

Bestellbeispiel Order example: 10 Stück 10 piece TNMM 270612-TEP oder or 5221076
 Farbliche Abbildung der WSP müssen nicht dem Original entsprechen!
 Colours of the original indexable inserts may deviate from the illustration!

- Verfügbar ab Lager Available from stock
- kurzfristig lieferbar available at short notice
- Auf Anfrage On request

Werkzeuge für die
Schweißkanten- Schweißnaht-
und- Rohrendenbearbeitung
Tools for weld edge processing-
weld seam scarfing and pipe end
preparing

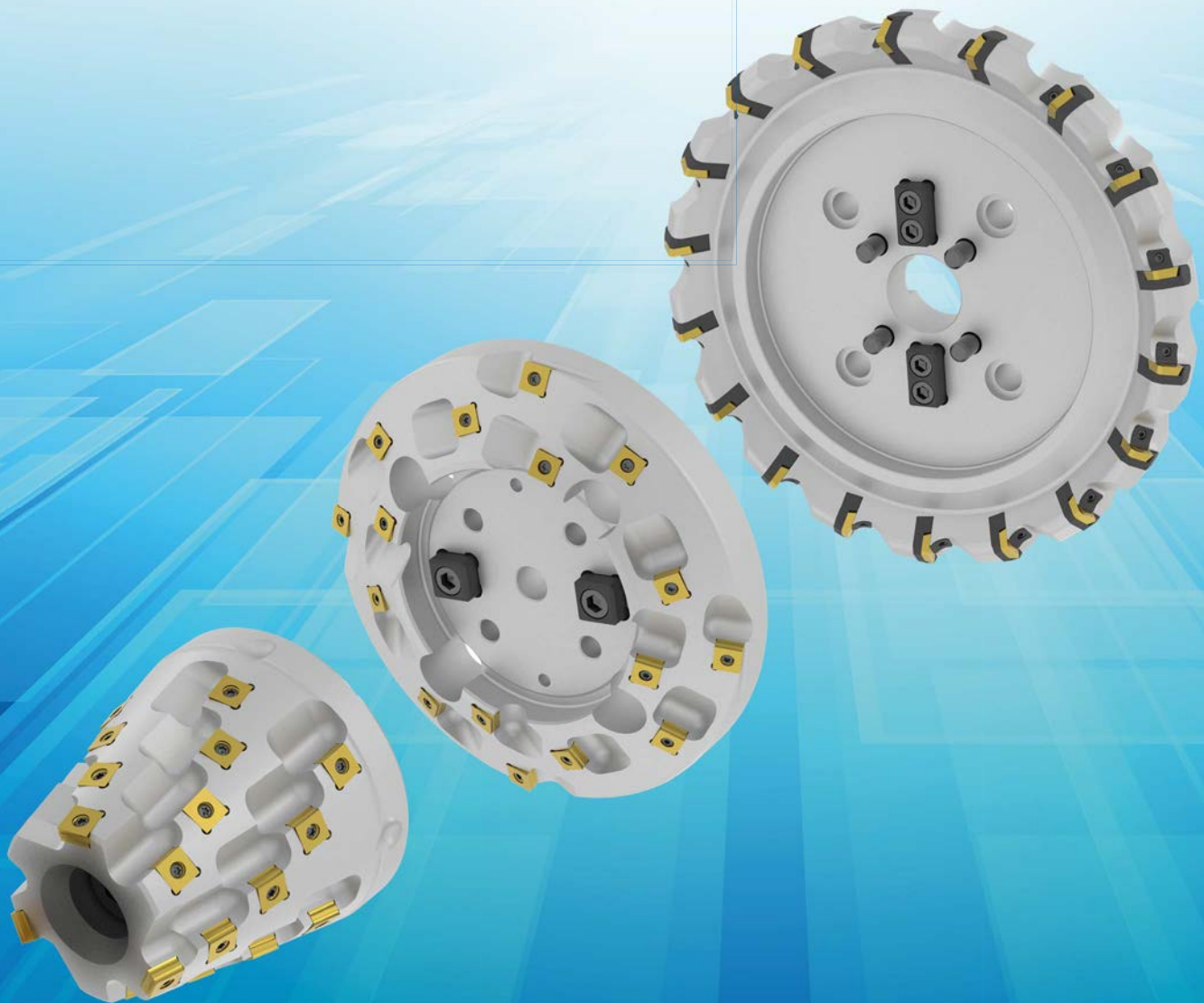

Wendeschnidplatte
Carbide insert

D-72-.... Bezeichnung der Kassetten
D-72-.... Nomination of cartridges

D-75-.... Bezeichnung des Fräskörpers
D-75-.....Nomination of milling body

D-30-.... Bezeichnung
des Distanzstückes
D-30-.....Nomination of
distance piece

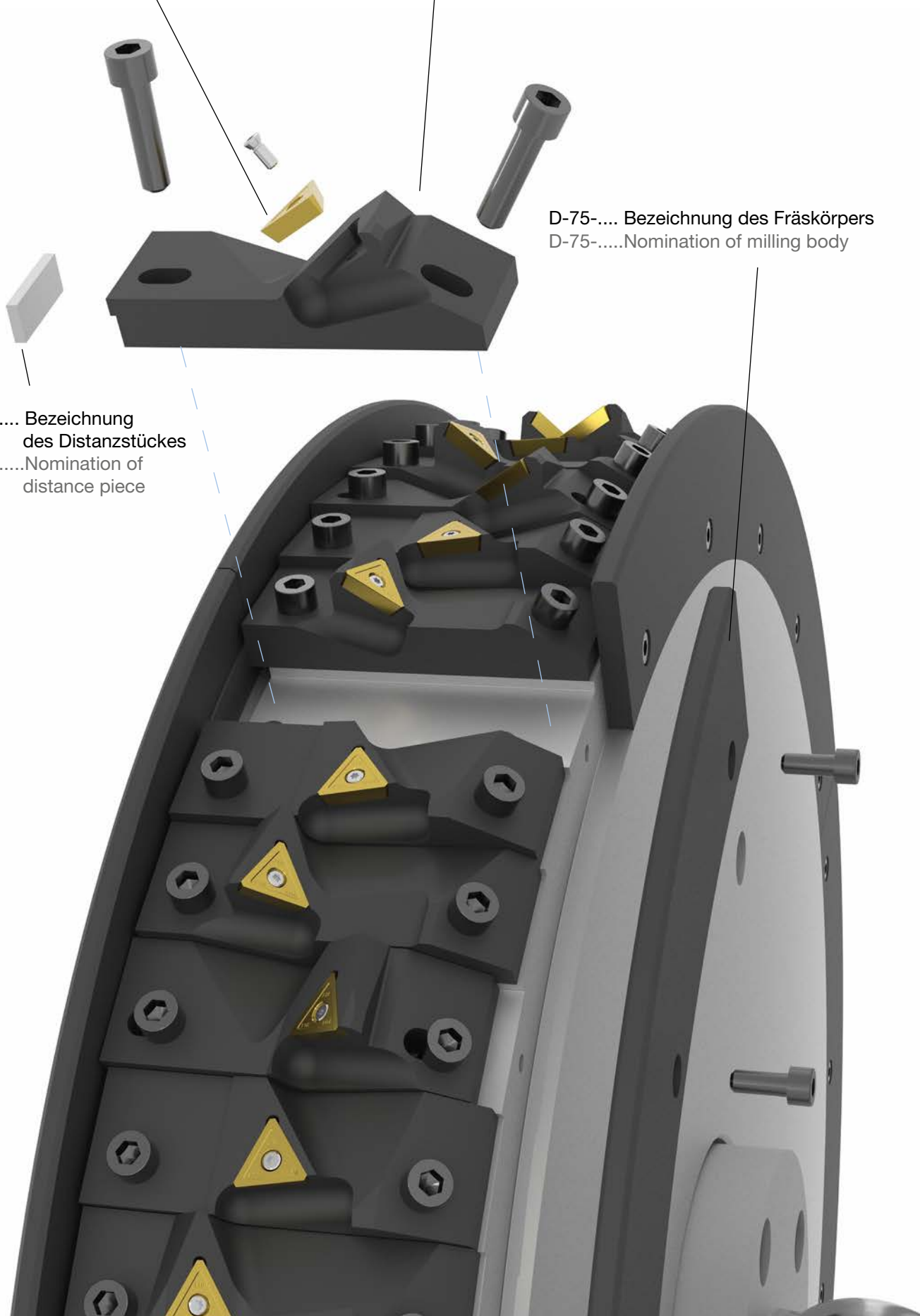

Vorteile des Systems

- Gestaltung der Spanttasche erlaubt die Maximierung von Vorschub und Frästiefe bei gleichzeitiger Vermeidung eines Spänestaus.
 - Kombination aus Anschlagring + Schutzblech erlaubt die Stegbreitenverstellung und schützt die Kassetten vor Beschädigung.
 - Distanzplatten ermöglichen Stegbreitenverstellung.
 - Mit dem Selben Grundkörper können durch den Tausch der Kassetten verschiedene Profile hergestellt werden.
 - Bei Beschädigung werden nur die Kassetten ohne zusätzliche Justierarbeit getauscht.
 - Geringer Umfang an Ersatzteilen. (Schrauben, Distanzplatten)
- Design of the chip pocket allows the maximizing of the feed as well as of the milling depth while simultaneously avoiding chip impact.
 - Combination of stop ring + protective plate allows web thickness adjustments of the face chamfer and protects the cartridge against damages.
 - Distance pieces allow adjustments of the face chamfer thickness.
 - Different profiles by exchanging the cartridges but using the same cutter body.
 - In case of damage, the cutter body is protected and cartridges can be replaced without any adjustment
 - Small amount of spare parts (screws, distance pieces)

I-Profil
 I-profile



I + V-Profil = X-Profil mit 2 seriellen Fräsern
 I + V-profile = X-profile with 2 serial cutters



X-Profil / Ein Fräser
 X-profile / One cutter



Y-Profil
 Y-profile



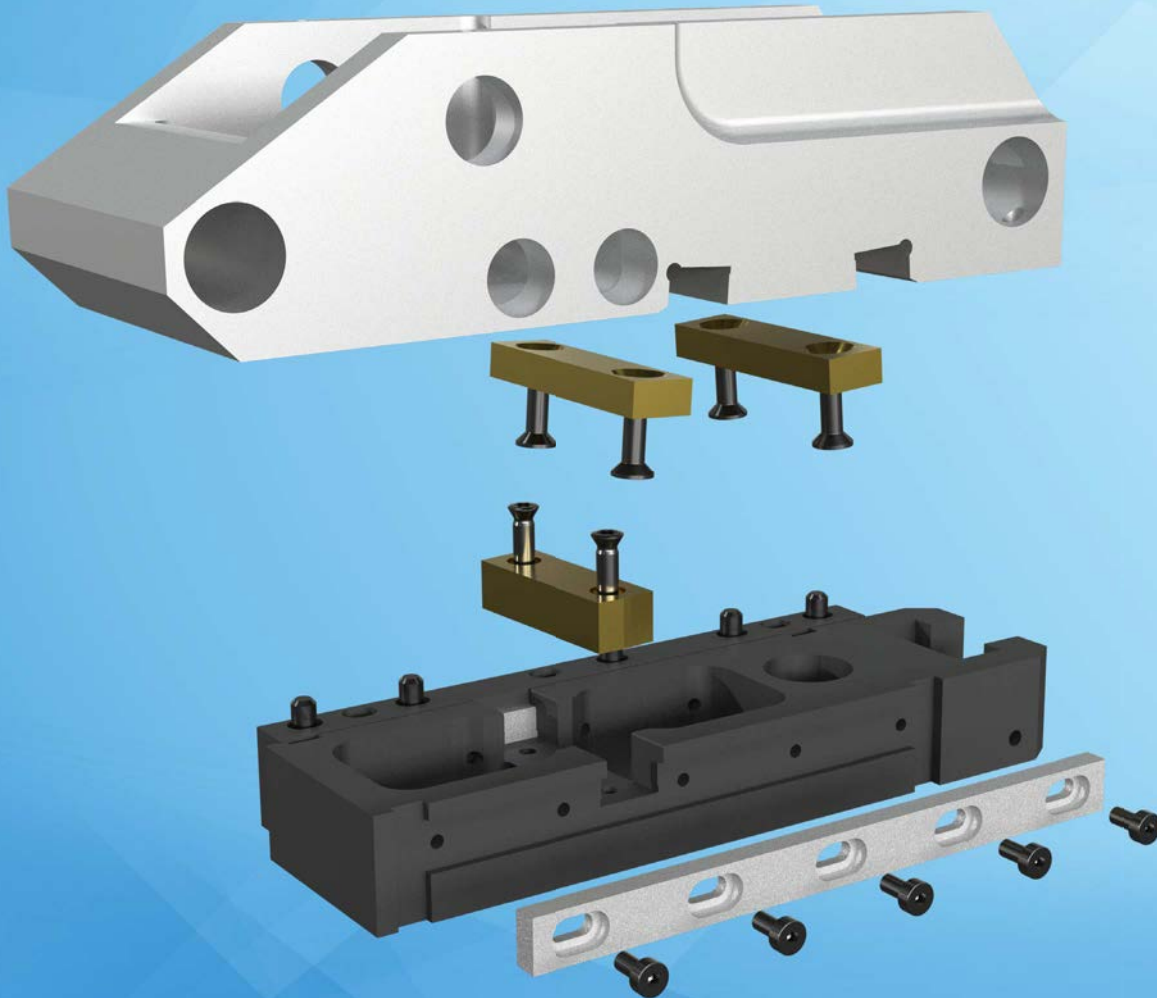

Besondere Merkmale:

- Hydraulisch/Pneumatisch betätigter oberer Schlitten um Spanbruch zu erreichen
- Geeignet für die Schweißnaht Innenbearbeitung von Rohren
- Hochpräzise Führung für exakte Schnittbewegung
- Anpassbar an unterschiedliche Rohrdurchmesser und Bearbeitungspositionen
- Spansystem mit Wechselmessern – schneller Messerwechsel ohne Neueinstellung
- Verschleißfeste Schneidplatte für lange Standzeit
- Schützt die Innenfläche des Rohres vor Kratzer und Beschädigungen durch lange Fließspäne

Special features:

- Hydraulically/Pneumatically actuated upper slide for chip breaking
- Suitable for internal weld seam machining of pipes
- High-precision guide for accurate cutting motion
- Adaptable to various pipe diameters and machining positions
- Clamping system with interchangeable blades – fast blade change without re-adjustment
- Wear-resistant cutting plate for extended tool life
- Protects the inner surface of the pipe from scratches and damage caused by long continuous chips

Schweißnahtbearbeitung außen, Klemhalter
Weld seam scarfing external, tool holder



Neutrale Version wie abgebildet, Links- oder Rechtsausführung möglich. Neutral version according to the image, left hand and right hand version possible	Artikelbezeichnung Item code	Bestell - Nr. Order No.	Verfügbarkeit Availability	Abmessungen [mm] Dimensions [mm]				Passende Wendeplatten Suitable inserts	Seite Page	
				H	H1	B	L			
	CSCP N 2925-R25	5244095	○	25,3	29,5	25,3	203	SPUX-250620	28	

Bestellbeispiel Order example: 1 Stück 1 piece CSCP

Ersatzteile Spare parts									
Unterlage Shim	Bestell-Nr. Order No.	Spannfinger Clamp finger	Bestell-Nr. Order No.	Spannschraube Fixation screw	Bestell-Nr. Order No.	Schraube für Spannfinger Screw for Clamping finger	Bestell-Nr. Order No.	Schlüssel Key	Bestell-Nr. Order No.
B03-SP2506-065	5063837	D07-T1-382308	5083292	M5x12 DIN7991	6406150	M8x25 DIN7991	5088671	V01-A0030	6407826

Bestellbeispiel Order example: 1 Stück 1 piece CSCP

Farbliche Abbildung der WSP müssen nicht dem Original entsprechen!
 Colours of the original indexable inserts may deviate from the illustration!

- Verfügbar ab Lager Available from stock
- kurzfristig lieferbar available at short notice
- Auf Anfrage On request

Schweißnahtbearbeitung außen, Klemmhalter
Weld seam scarfing external, tool holder

Rechtsausführung gezeichnet, Linksausführung spiegelbildlich. Right hand version shown, left hand version mirrorlike	Artikelbezeichnung Item code	Bestell - Nr. Order No.	Verfügbarkeit Availability	Abmessungen [mm] Dimensions [mm]				Passende Wende- platten Suitable inserts	Seite Page
				H	H1	B	L		
	PXFNR 2525-M15	6412674	o	25	25	25	150	SNMX-1507	24
	PXFNL 2525-M15	6412671	o	25	25	25	150	SNMX-1507	
	PXFNR 2525-M19	6412675	o	25	25	25	150	SNMX-1907	26
	PXFNL 2525-M19	6412672	o	25	25	25	150	SNMX-1907	
	PXFNR 2525-S25	6412676	o	25	25	25	250	SNMX-2512	27
	PXFNL 2525-S25	6412673	o	25	25	25	250	SNMX-2512	
	PSFNR 2525-M15	5017932	o	25	25	25	150	SNMG-1507	24
	PSFNL 2525-M15	5084895	o	25	25	25	150	SNMG-1507	
	PSFNR 2525-M19	5084898	o	25	25	25	150	SNMG-1907	26
	PSFNL 2525-M19	5084896	o	25	25	25	150	SNMG-1907	
	PSFNR 2525-S25	5084899	o	25	25	25	250	SNMG-2512	27
	PSFNL 2525-S25	5084897	o	25	25	25	250	SNMG-2512	

Ersatzteile Spare parts											
Unterlage Shim	Bestell-Nr. Order No.	Kniehebel Lever	Bestell-Nr. Order No.	Spann- schraube Fixation screw	Bestell-Nr. Order No.	Spannhülse Shims pin	Bestell-Nr. Order No.	Montagedorn Assembly punch	Bestell-Nr. Order No.	Schlüssel Key	Bestell-Nr. Order No.
B04-S07-SN15-042	6412365	D02-15145	6403965	A03-08235	6401282	E01-07205	6404739	V10-20000	6407853	V01-A0030	6407826
B04-S07-SN15-028	5242967										
B04-S10-SN19-056	6412366	D02-19210	6403968	A03-10270	6401283	E01-11011	6404742	V10-30000	6407854	V01-A0040	6407828
B04-S10-SN19-042	5242968										
B04-S13-SN25-071	6412367	D02-23250	6403969	A03-12360	6401285	E01-15212	6404743	V10-50000	6407856	V01-A0050	6407829
B04-S13-SN25-052	5242969										

	Artikelbezeichnung Item code	Bestell - Nr. Order No.	Verfügbarkeit Availability	Abmessungen [mm] Dimensions [mm]				Passende Wende- platten Suitable inserts	Seite Page	
				H	H1	B	L			
	SHCXN 2222-S24	5238043	o	22	22	22	250	ROMX2404-R	23	

Ersatzteile siehe nächste Seite!
 Spare parts see next page!

Bestellbeispiel Order example: 1 Stück 1 piece PXFNR 2525-M15 oder or 6412674

Ersatzteile Spare parts SHCXN 2222-S24							
Anschlagplatte Back up plate	Bestell-Nr. Order No.	Spannschraube Clamping screw	Bestell-Nr. Order No.	Stellschraube Socket head cap screw	Bestell-Nr. Order No.	Schlüssel Key	Bestell-Nr. Order No.
		M5x16 DIN7991	6412644			V01-A0030 SW3	6407826
C01-L05-3616	6412559			M5x12 DIN912	6406151	V01-A0040 SW4	6407828

	Artikel- bezeichnung Item Code	Bestell-Nr. Ordering No.	Verfügbarkeit Availability	Gewinde Thread	H	L1	B	L	Passende Wende- platten Suitable inserts	Seite Page
	SXCXN 4825-X25	5200224	o	M8	40,67	48	25	45,8	ISD 25-...	22

	Artikel- bezeichnung Item Code	Bestell-Nr. Ordering No.	Verfügbarkeit Availability	Gewinde Thread	H	L1	B	L	Passende Wende- platten Suitable inserts	Seite Page
	SXCXN 5720-H20	5108807	o		38	57	20	102	ISD 20-...	22

Bestellbeispiel Order example: 1 Stück 1 piece SXCXN 4825X25 oder or 5200224

- Verfügbar ab Lager Available from stock
- ⦿ kurzfristig lieferbar available at short notice
- Auf Anfrage On request

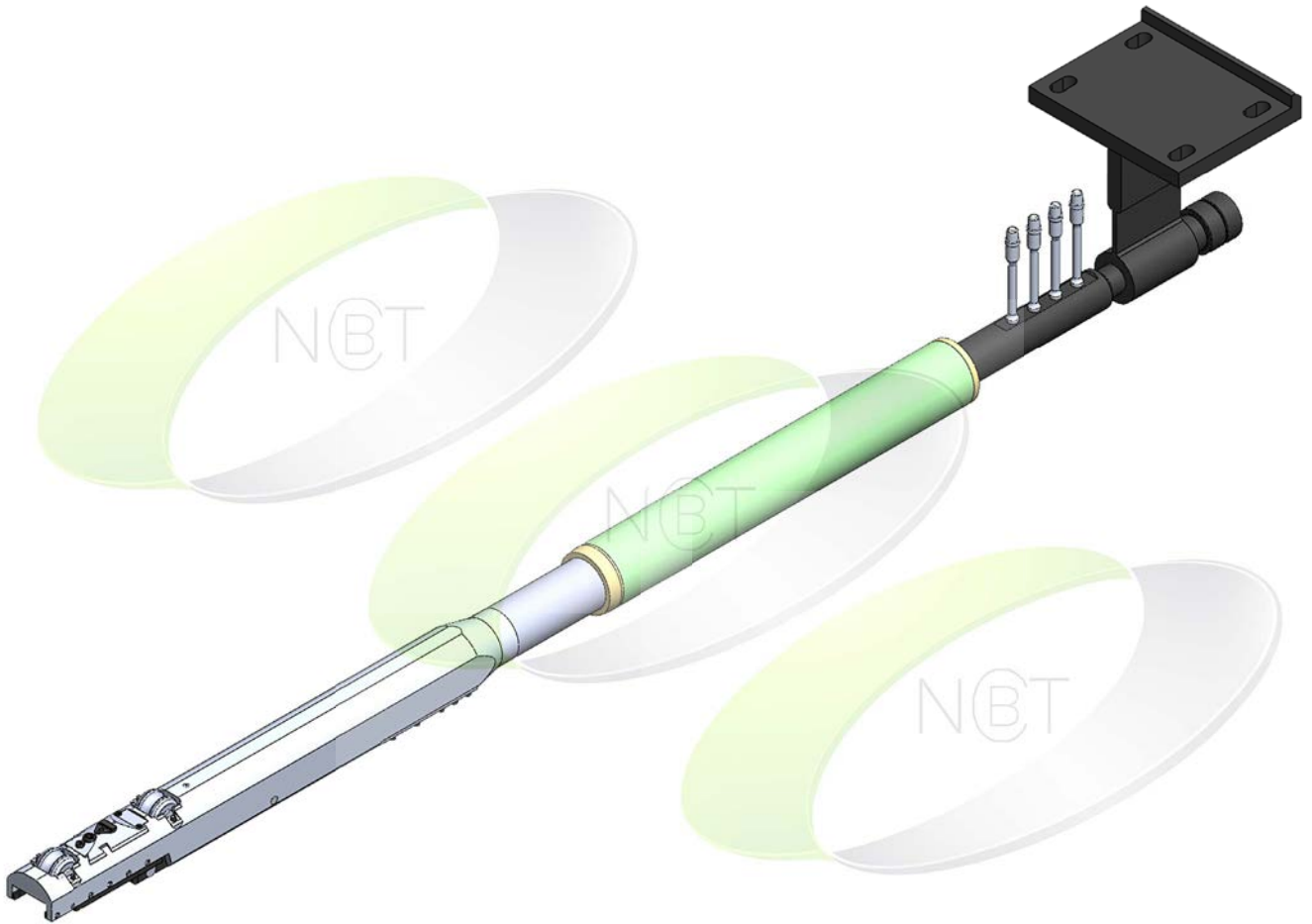

Besondere Merkmale:

- Vermeidung von Grubenbildung
- Es kann mit einer Wägezellen-(Load-Cell-)Einheit ausgestattet werden.
- Endoskopkamera im Schälwerkzeug integrierbar.
- Verschiedene Produktionsbereiche (AD 12,7 mm bis 660 mm)
- Konstruktion und Herstellung.
- Größenbereich von AD 12,7 mm bis 660 mm mit sieben verschiedenen Typen:
 - Mechanischer Typ: AD 12,7 mm bis 660 mm
 - Mechanischer Häcksler-Typ: AD 60,5 mm bis 660 mm
 - Hydraulischer Typ: AD 48,6 mm bis 660 mm
 - Hydraulischer Häcksler-Typ: AD 73 mm bis 660 mm
 - Ausleger-Typ: AD 177,8 mm bis 660 mm
 - Ausleger-Häcksler-Typ: AD 177,8 mm bis 660 mm
 - Ausleger-Häcksler-Typ mit Endoskopkamera: AD 177,8 mm bis 660 mm

Special features:

- Pit prevention
- It is able to equip load-cell type
- Endoscopic camera equipped in the scarfing tool
- Various ID Scarfing Tool Production Range (OD 12.7mm to 660mm)
- Capability in customized designing and manufacturing.
- Size from OD 12.7mm to 660mm with seven different types:
 - Mechanical type OD 12.7mm to 660mm
 - Mechanical Chopper Type OD 60,5mm to 660mm
 - Hydraulic Typ OD 48,6mm to 660mm
 - Hydraulic chopper type OD 73mm to 660mm
 - Cantilever type OD 177,8mm to 660mm
 - Cantilever chopper type OD 177,8mm to 660mm
 - Cantilever chopper type + endoscopic camera OD 177,8mm to 660mm



Besondere Merkmale:

- Wendschneidplatte mit 6 Schneidkanten für erhöhte Wirtschaftlichkeit
- Speziell entwickeltes Design für herausfordernde Anwendungen
- Zwei Geometrie für bestmögliche Ergebnisse
- High End Werkzeughalter optimiert je nach Einsatzzweck
- 3D-Druck für Prototypen sowie verkürzte Lieferzeiten
- Interne optimierte Kühlmittelzufuhr direkt an die Schneide

Special features:

- Indexable insert with 6 cutting edges for increased efficiency
- Specially developed design for challenging applications
- Two geometries for the best results
- High-end tool holder optimized depending on the application
- 3D printing for prototypes and shorter delivery times
- Internal optimized coolant directly to the cutting edge

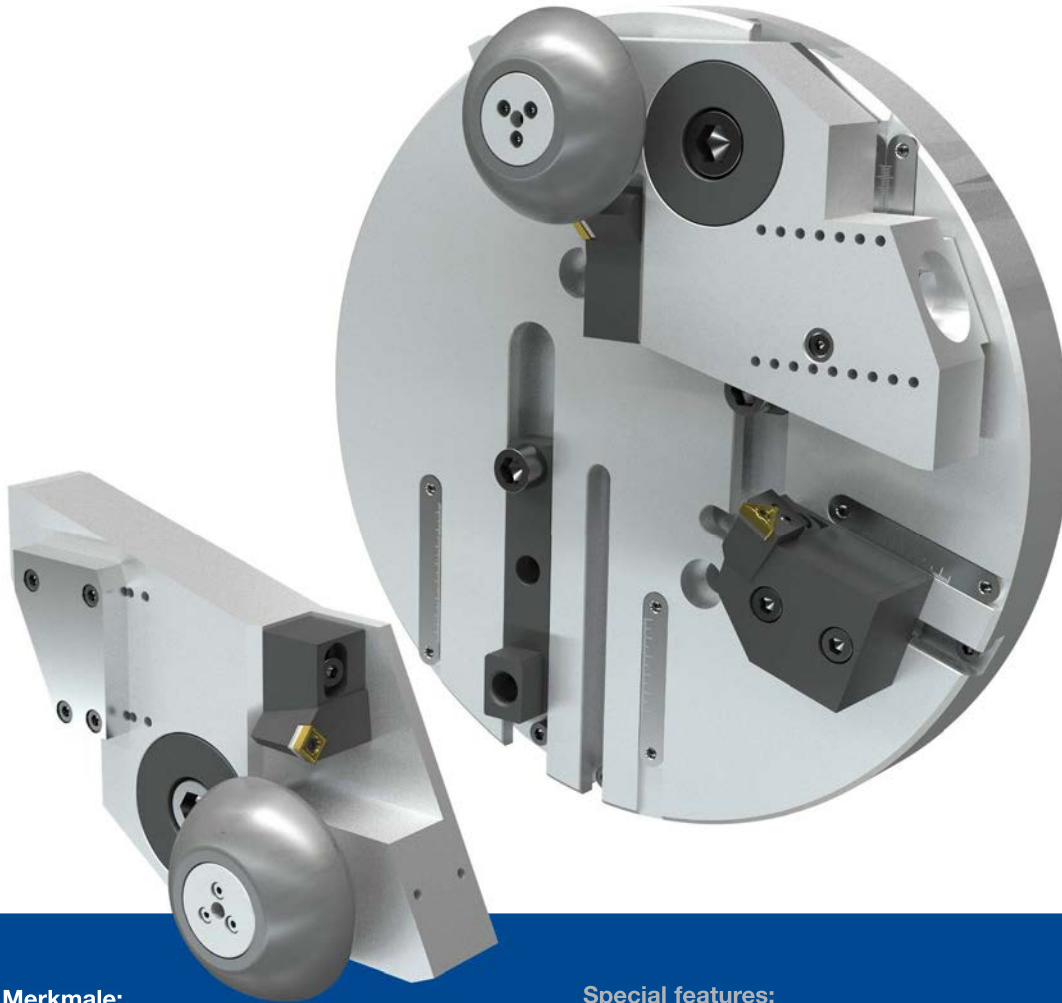

Besondere Merkmale:

- Kombiniertes System für Planbearbeitung, Innen- und Außenfase
- Kopierrolle mit federbelastetem Lagerpaket passt sich automatisch der Rohrkontur an
- Gleichmäßige Fasenbildung unabhängig von Ovalität oder Maßabweichungen
- Modulare Bauweise für verschiedene Rohrdurchmesser
- Platzsparende Konstruktion – ideal für kleine Nennweiten und enge Bearbeitungsräume
- Robuste Kassettentechnik mit Wendeschneidplatten für präzise und wirtschaftliche Bearbeitung

Special features:

- Combined system for facing, internal and external beveling
- Copying roller with spring-loaded bearing assembly automatically adapts to pipe contour
- Consistent bevel formation regardless of ovality or dimensional deviations
- Modular design for various pipe diameters
- Space-saving construction – ideal for small nominal sizes and tight machining areas
- Robust cassette system with indexable inserts for precise and cost-effective machining

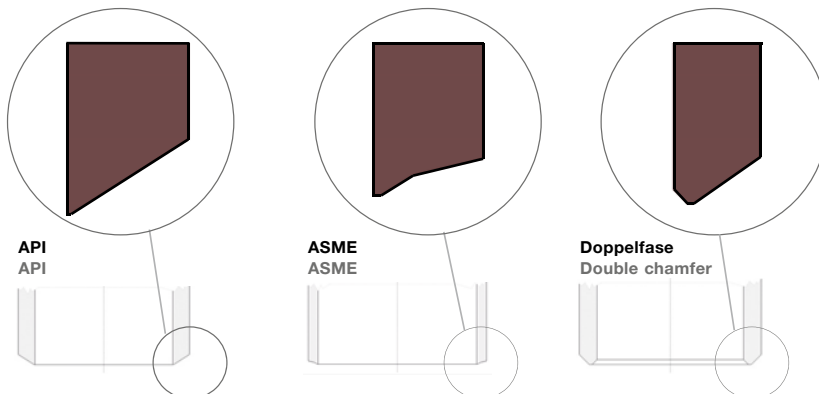

Die Flexibilität des Systems garantiert verschiedene Fasausführungen entsprechend dem Standard wie z. B. API oder ASME

Flexibility of the system guarantees various chamfer designs according to standards like API or ASME

Verschiedene Profile entsprechend der Kundenspezifikation sind möglich.
Different profiles according to customers specifications possible

Linksausführung gezeichnet, Rechtsausführung spiegelbildlich. Left hand version shown, right hand version mirrorlike	Artikelbezeichnung Item code	Bestell Nr. Order No.	Verfügbarkeit Availability	Abmessungen [mm] Dimensions [mm]					Wende-platten Indexable inserts	Seite Page	
				α	B	F	L	L1			
	K-2-1-45°-R	6412581	○	45°	64	48	72	11,0	SNMM2507...	37	
	K-2-1-45°-L	5222372	○	45°	64	48	72	11,0			

Ersatzteile Spare parts									
Auflageplatte Shim	Bestell-Nr. Order No.	Kniehebel Lever	Bestell-Nr. Order No.	Spannschraube Fixation screw	Bestell-Nr. Order No.	Rohrstift Shim pin	Bestell-Nr. Order No.	Schlüssel Key	Bestell-Nr. Order No.
B04-S13-SW25-064	6401838	D02-23250	6403969	A03-12290	6404312	E01-152212	6404743	V01-A0030	6407826

***)Kundenspezifische Winkelausführung auf Anfrage! Wir beraten Sie gerne!**
***)Customized angle designs on request! We will be happy to advise you!**
0° - 45°
LH & RH

Kassetten und Ersatzteile zur Rohrendenbearbeitung
Cartridges and spare parts for pipe end beveling

Linksausführung gezeichnet, Rechtsausführung spiegelbildlich. Left hand version shown, right hand version mirrorlike	Artikelbezeichnung Item code	Bestell Nr. Order No.	Verfügbarkeit Availability	Abmessungen [mm] Dimensions [mm]					Wendeplatten Inserts	Seite Page		
				α	B	F	L	L1				
<p>K-7-1</p>	K-7-1-12,5°-L	5000656	o	12,5°	60,8	48	82	58,5	LNUX 70..	36		

Bestellbeispiel Order example: 1 Stück 1 piece K-7-1-12,5°-L oder or 5000656

Lieferung ohne Schlüssel und Montagedor
 Delivery without key and mounting pin

Ersatzteile Spare parts									
Auflageplatte Shim	Bestell-Nr. Order No.	Kniehebel Lever	Bestell-Nr. Order No.	Spannschraube Fixation screw	Bestell-Nr. Order No.	Schraube ISO4762 screw	Bestell-Nr. Order No.	Schlüssel Key	Bestell-Nr. Order No.
B03-LN7012-052	6410392	D02-23250	6403969	A03-12290	6404312	M5x12 DIN7984	6413195	V01-A0030	6407826.

***)Kundenspezifische Winkelausführung auf Anfrage! Wir beraten Sie gerne!**
***)Customized angle designs on request! We will be happy to advise you!**
0° - 45°
LH & RH

Linksausführung gezeichnet, Rechtsausführung spiegelbildlich. Left hand version shown, right hand version mirrorlike	Artikelbezeichnung Item code	Bestell Nr. Order No.	Verfügbarkeit Availability	Abmessungen [mm] Dimensions [mm]					Wendeplatten Inserts	Seite Page		
				α	B	F	L	L1				
KT-2-1- α -L 	KT-2-1-45°-R	5222467	○	45°	53	48	72	22	TNMM 2706..	38		

Bestellbeispiel Order example: 1 Stück 1 piece KT-2-1-45°-R oder or 5222467

Lieferung ohne Schlüssel
 Delivery without key

Ersatzteile Spare parts									
Auflageplatte Shim	Bestell-Nr. Order No.	Spannschraube Fixation screw	Bestell-Nr. Order No.	Rohrstift Shim pin	Bestell-Nr. Order No.	Kniehebel Lever	Bestell-Nr. Order No.	Schlüssel Key	Bestell-Nr. Order No.
B04-S06-TN27-032	5206613	A03-08210	6401281	E01-07205	6404739	D02-15145	6403965	V04-T1500	6407846

Farbliche Abbildung der WSP müssen nicht dem Original entsprechen!
 Colours of the original indexable inserts may deviate from the illustration!

- Verfügbar ab Lager Available from stock
- kurzfristig lieferbar available at short notice
- Auf Anfrage On request

Kassetten und Ersatzteile zur Rohrendenbearbeitung
Cartridges and spare parts for pipe end beveling

Linksausführung gezeichnet, Rechtsausführung spiegelbildlich. Left hand version shown, right hand version mirrorlike	Artikelbezeichnung Item code	Bestell Nr. Order No.	Verfügbarkeit Availability	Abmessungen [mm] Dimensions [mm]					Wendeplatten Inserts	Seite Page	
				α	B	F	L	L1			
	KT-4-1-32,5°-L	5185483	o	32,5°	66,5	48	72	31	TNMT 4409..	38	

Bestellbeispiel Order example: 1 Stück 1 piece KT-4-1-32,5°-R oder or 5185483

Lieferung ohne Schlüssel
 Delivery without key

Ersatzteile Spare parts							
Auflageplatte Shim	Bestell-Nr. Order No.	Gewindehülse Shim screw	Bestell-Nr. Order No.	Klemmschraube Fixation screw	Bestell-Nr. Order No.	Schlüssel Key	Bestell-Nr. Order No.
	B04-B12-TN44-052		E02-F12080		A02-80250		6119533
	5065569		6404745		6401272	Torx 30	



***)Kundenspezifische Winkel Ausführung auf Anfrage! Wir beraten Sie gerne!**
***)Customized angle designs on request! We will be happy to advise you!**
0° - 45°
LH & RH

Farbliche Abbildung der WSP müssen nicht dem Original entsprechen!
 Colours of the original indexable inserts may deviate from the illustration!

- Verfügbar ab Lager Available from stock
- ⦿ kurzfristig lieferbar available at short notice
- Auf Anfrage On request

Werkzeugauswahl mit Bezug auf Faswinkel und Wandstärke Choice of tool in relation to chamfer angle and wall thickness

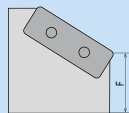
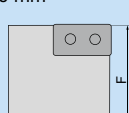

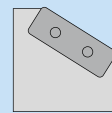
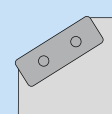
K Werkzeugtyp Type of tool	T WSP Insert	4 Plattenlänge in mm Length of cutting edge in mm	1 f-Maß in mm Measure f in mm	45° Faswinkel α chamfer angle α	L Schnittrichtung Direction of cut
K = Kassette = Cartridge	T = Dreiecks- platte = Triangle insert mit with WSP TNM. Insert TNM.	mm	 1 = 48 mm 2 = 50 mm 	 α° : 0 2 4 6 7 8 10 15 22 25 27 30 32 35 37 40 45 50	L  R 
		mm			
		Wendeplatte Indexable insert			
		2 = 25,4			
		3 = 33,0			
		3 = 33,0			
		4 = 44,0			
		4 = 40			
		4 = 40			
		5 = 50			
		5 = 50			
		6 = 60			
		6 = 60			
		7 = 70			
		7 = 70			
) : alte Bezeichnung old designation			
		*Tulpenprofil Tulip profile			

Bezeichnungssystem für Kassetten für die Rohrendenbearbeitung Designation system for cartridges for pipe end preparation

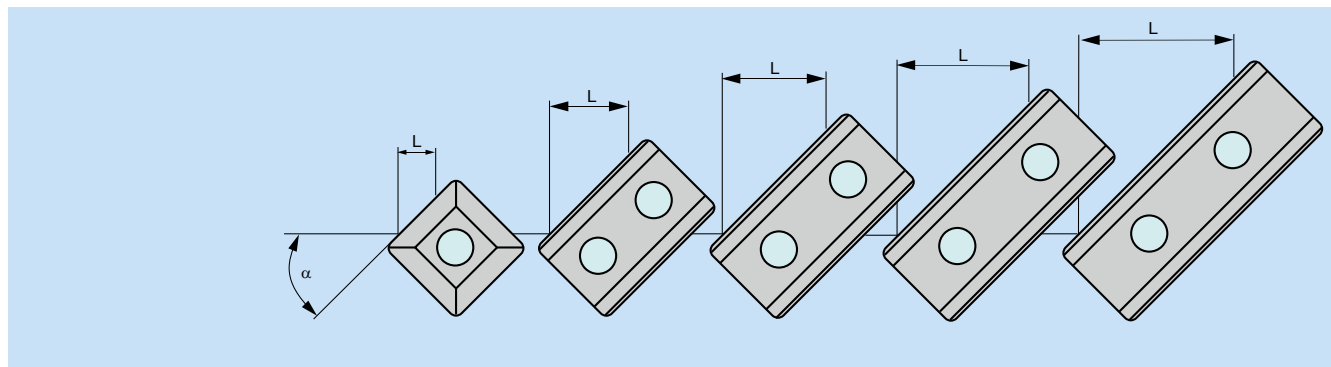

Kassette Cartridge	K-2 R/L	K-4 R/L	K-5 R/L	K-6 R/L	K-7 R/L
Wendeplatte Indexable insert	SNMM 25	LNUX 40	LNUX 50	LNUX 60	LNUX 70
Fase Chamfer	L = max.Wandstärke L = Maximum wall Thickness				
$\alpha = 0^\circ$	16,0	32,0	40,0	50,0	60,0
$\alpha = 2^\circ$	16,0	32,0	40,0	50,0	60,0
$\alpha = 3^\circ$	16,0	32,0	40,0	50,0	60,0
$\alpha = 4^\circ$	16,0	32,0	40,0	49,5	60,0
$\alpha = 5^\circ$	15,5	32,0	40,0	49,5	59,5
$\alpha = 6^\circ$	15,5	32,0	40,0	49,5	59,5
$\alpha = 7^\circ$	15,5	32,0	39,5	49,5	59,5
$\alpha = 10^\circ$	15,5	31,5	39,5	49,0	59,0
$\alpha = 12,5^\circ$	15,5	31,0	39,0	48,5	58,5
$\alpha = 15^\circ$	15,5	31,0	38,5	48,0	58,0
$\alpha = 17,5^\circ$	15,0	30,5	38,0	47,5	57,0
$\alpha = 20^\circ$	15,0	30,0	37,5	46,5	56,0
$\alpha = 22^\circ$	15,0	29,5	37,0	46,0	55,0
$\alpha = 25^\circ$	14,5	29,0	36,0	45,0	54,0
$\alpha = 27^\circ$	14,0	28,5	35,5	44,0	53,0
$\alpha = 30^\circ$	14,0	27,5	34,5	43,0	51,0
$\alpha = 32^\circ$	13,5	27,0	34,0	42,0	50,0
$\alpha = 35^\circ$	13,0	26,0	32,5	40,5	48,0
$\alpha = 37^\circ$	12,5	25,5	32,0	39,5	47,0
$\alpha = 40^\circ$	12,0	24,5	30,5	37,5	45,0
$\alpha = 45^\circ$	11,0	22,5	28,0	34,5	41,0

Kassetten zur Rohrendenbearbeitung
Cartridges for pipe end machining

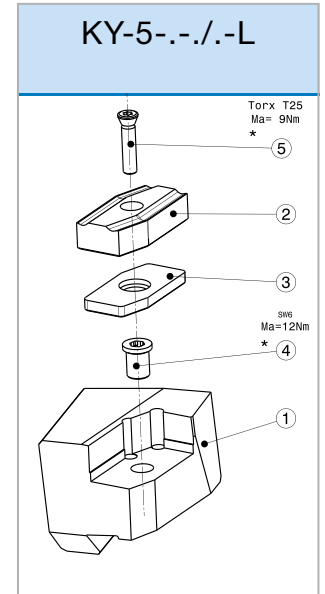
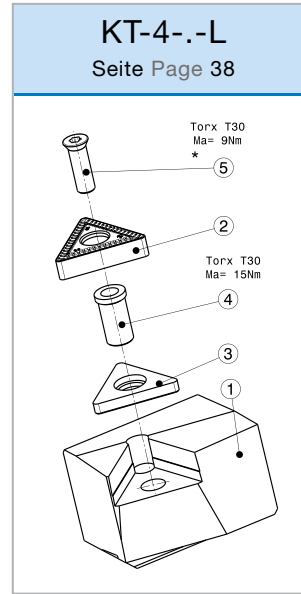
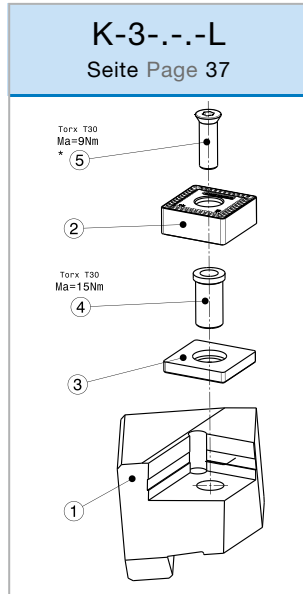
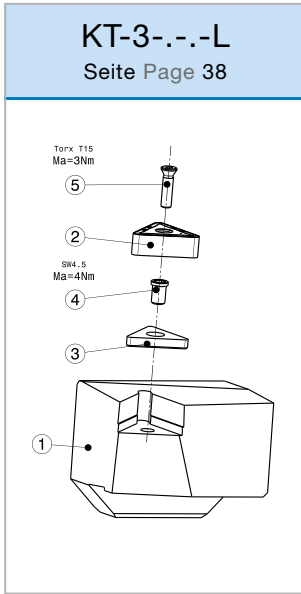

Schnittdatenrichtwerte Rohrendenbearbeitung
Cutting data recommendations pipe end preparation

Mittlerer Rohrdurchmesser Zoll Od pipe diameter inch	Schnittgeschwindigkeit m/min. Cutting speed m/min.	Drehzahl U/min. Revolu-tion r.p.m.	Vorschub mm/min min. Feed mm/min min.	Vorschub mm/min max. Feed mm/min max.	Schnittgeschwindigkeit m/min. Cutting speed m/min.	Drehzahl U/min. Revolu-tion r.p.m.	Vorschub mm/min min. Feed mm/min min.	Vorschub mm/min max. Feed mm/min max.	Schnittgeschwindigkeit m/min. Cutting speed m/min.	Drehzahl U/min. Revolu-tion r.p.m.	Vorschub mm/min min. Feed mm/min min.	Vorschub mm/min max. Feed mm/min max.
Stahl St37 (B) Steel St37 (B)												
	Wandstärke Zoll Wall thickness inch 0,375 / 0,500 / 0,625 / 0,750				Wandstärke Zoll Wall thickness inch 0,875 / 1,000				Wandstärke Zoll Wall thickness inch 1,250 / 1,500			
24	139,8	73	33	40	120,6	63	22	28				
26	139,0	67	30	37	120,3	58	20	26				
28	138,5	62	28	34	120,6	54	19	24				
30	138,8	58	26	32	119,7	50	17	22	100,5	42	10	15
32	140,4	55	25	30	120,0	49	16	21	99,6	39	10	14
34	138,4	51	23	28	119,4	44	15	20	100,4	37	9	13
36	140,8	49	22	27	120,7	42	14	19	100,5	35	9	12
38	139,5	46	21	26	118,3	39	13	17	100,1	33	8	12
40	140,4	44	20	24	118,1	37	13	17	98,9	31	8	11
42	140,8	42	19	23	120,6	36	13	16	100,5	30	7	10
44	140,4	40	18	22	119,4	34	12	15	98,3	28	7	10
45	139,5	38	17	21	121,1	33	12	15	99,1	27	7	9
48	137,9	36	16	20	118,7	31	11	14	99,6	26	6	9
50	139,6	35	16	19	119,7	30	10	13	99,7	25	6	9
52	141,0	34	15	19	120,3	29	10	12	99,6	24	6	8
54	137,9	32	14	18	120,6	28	10	12	99,1	23	6	8
56	138,5	31	14	17	120,6	27	9	12	98,3	22	5	8
58	138,8	30	13	17	120,3	26	9	12	97,2	21	5	7
60	138,8	29	13	16	119,7	25	9	11	96,0	20	5	7
62	138,5	28	13	15	118,7	24	8	11	98,9	20	5	7
64	137,9	27	12	15	117,5	23	8	10	97,0	19	5	7

Boehlerit GmbH & Co. KG
Werk VI-Strasse 100
8605 Kapfenberg
Österreich/Austria
Telefon +43 3862 300 - 0
Telefax +43 3862 300 - 793
info@boehlerit.com
www.boehlerit.com

boehlerit



台北 02-2703-0193
台中 04-2463-6890



www.gcarbide tool.com